

# brother

## BAS-612

自動本縫斜め玉縁機 <フラップ付用>

**AUTOMATIC LOCKSTITCH SLANT POCKET WELT SEWER  
<FOR FLAP ATTACHMENT>**

**AUTOMATISCHE VERRIEGELUNGSSTICH-TASCHEANNAHMASCHINE  
<FÜR PATTENBEFESTIGUNG>**

**MACHINE A COUDRE AUTOMATIQUE A POINT NOUE POUR POCHE  
PASSEPOILEES INCLINEES <POUR FIXATION DE PATTE>**

**MAQUINA DE COSER PESPUNTES PARA DOBLADILLOS DE BOLSILLOS  
INCLINADOS AUTOMATICA <PARA COLOCACION DE TAPAS>**

パーツブック  
PARTS BOOK  
TEILEKATALOG  
LIVRE DES PIECES  
LIBRO DE REFERENCIA DE PIEZAS

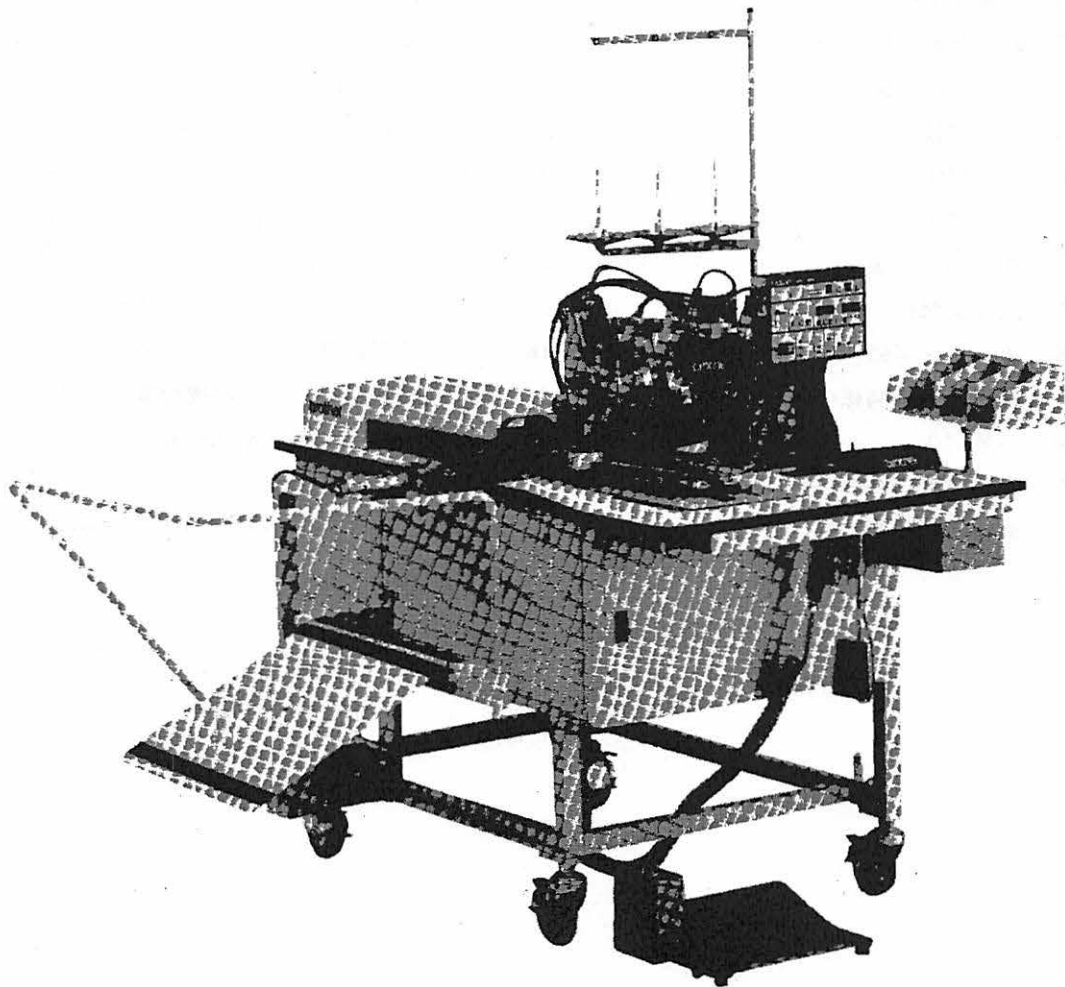

## パーツブックご利用に際して

1. 組単位で補給する部品は、破線で示しております。
2. この本は1989年8月のデータに基づいて作成されたものです。
3. 部品は予告なしに設計変更される場合があります。
4. 部品コード欄が\*となっている場合は、ゲージ部品一覧表(73ページ)でお調べ下さい。

## 目 次

A. 主体関係.....	2	Q. コントロールボックス関係.....	32
B. 上軸関係.....	2	R. 空圧関係.....	34
C. 針棒揺動関係.....	4	S. 電装品関係.....	38
D. 針棒切換工操作関係.....	6	T. 布制御関係.....	40
E. 下軸関係.....	6	U. 踏板関係.....	56
F. メス関係.....	8	V. 動力台関係.....	58
G. カマ関係.....	10	W. ゲージ部品関係.....	64
H. 給油潤滑関係.....	12	X. 特別注文部品.....	66
J. 糸通シ関係.....	16	X. 特別注文部品(ダーツノバシ).....	68
K. 糸ユルメ関係.....	18	X. 特別注文部品(エアージェクター).....	70
L. スタッカー関係.....	20	Z1. 付属品関係(自動機付属).....	70
M. 糸巻関係.....	28	Z2. 付属品関係(頭部付属).....	72
N. 糸切り関係.....	30	ゲージ部品一覧表.....	73
P. 針位置検出器関係.....	32	索 引.....	78

## Notes for using this parts book

1. Parts supplied as complete assemblies are circled by a dotted line ( ).
2. This book was prepared based on information available in August 1989.
3. Parts are subject to changes in design without prior notice.
4. If the symbol \* is found in the "Parts No." column, refer to the parts list (gauge parts list) on page 73.

## CONTENTS

A. Machine body .....	2	R. Air pressure mechanism .....	34
B. Upper shaft mechanism .....	2	S. Power supply equipment mechanism .....	38
C. Needle bar rocking mechanism .....	4	T. Cloth control system mechanism .....	40
D. Needle bar flip-up mechanism .....	6	U. Treadle mechanism .....	56
E. Lower shaft mechanism .....	6	V. Power table .....	58
F. Knife mechanism .....	8	W. Gauge parts assembly .....	64
G. Rotary hook mechanism .....	10	X. Option part .....	66
H. Lubrication .....	12	X. Option part (Darts stretcher) .....	68
J. Threading mechanism .....	16	X. Option part (Air ejector) .....	70
K. Tension release mechanism .....	18	Z1. Accessories (provided with automatic sewing machine) .....	70
L. Stacker mechanism .....	20	Z2. Accessories (provided with machine body) .....	72
M. Bobbin winder mechanism .....	28	GAUGE PARTS LIST .....	73
N. Thread trimmer mechanism .....	30	INDEX .....	78
P. Synchronizer .....	32		
Q. Control box mechanism .....	32		

## Anmerkungen zum Gebrauch dieser Teileliste

1. Die Teile, die als kompletter Satz geliefert werden, sind mit einer    gestrichelten Linie umrandet.
2. Dieses Buch basiert auf den Informationen vom August 1989.
3. Modelländerungen sind vorbehalten.
4. Dieses Zeichen \* in der Spalte "Parts No. (Teilnummer)" verweist auf die Teileliste (Lehrenliste) auf Seite 73.

## INHALTSVERZEICHNIS

A. Maschinengehäuse .....	2	R. Luftdruck .....	34
B. Obere Welle .....	2	S. Stromversorgung .....	38
C. Nadelstangenbetätigung .....	4	T. Stoffführungsvorrichtung .....	40
D. Nadelstangehochstellung .....	6	U. Fußbetätigung .....	56
E. Untere Welle .....	6	V. Motorgestell .....	58
F. Messer .....	8	W. Lehrenteile .....	64
G. Greifervorrichtung .....	10	X. Sonderteile .....	66
H. Schmierung .....	12	X. Sonderteile (Abnäherstrecker) .....	68
J. Fadenführungsvorrichtung .....	16	X. Sonderteile (Luftausstosser) .....	70
K. Spannungsverminderungsvorrichtung .....	18	Z1. Zubehör (mit automatischer Nähmaschine) .....	70
L. Anhäufung .....	20	Z2. Zubehör (mit Nähmaschine) .....	72
M. Spuler .....	28	LEHRENLISTE .....	73
N. Fadenabschneidevorrichtung .....	30	VERZEICHNIS .....	78
P. Synchronisator .....	32		
Q. Schaltkasten .....	32		

## Notes sur l'utilisation de ce manuel de pièces détachées

1. Les pièces fournies en tant qu'assemblages complets sont encadrées avec un trait pointillé .
2. Ce manuel a été fait d'après les renseignements valables au mois de Août 1989.
3. Les pièces peuvent être sujettes à des modifications sans préavis.
4. Si le symbole \* se trouve dans la colonne "Parts No. (N° de pièce)" veuillez la vous référer à la liste de pièces (liste des pièces d'écartement) page 73.

## TABLE DES MATIERES

<p>A. Corps de la machine ..... 2</p> <p>B. Mécanisme de l'arbre supérieur ..... 2</p> <p>C. Mécanisme de balancement de la barre à aiguille ..... 4</p> <p>D. Mécanisme de sautée de la barre à aiguille ..... 6</p> <p>E. Mécanisme de l'arbre inférieur ..... 6</p> <p>F. Mécanisme du couteau ..... 8</p> <p>G. Mécanisme du crochet rotatif ..... 10</p> <p>H. Lubrification ..... 12</p> <p>J. Mécanisme de l'enfilage ..... 16</p> <p>K. Mécanisme de relâche de tension ..... 18</p> <p>L. Mécanisme de l'emplieur ..... 20</p> <p>M. Mécanisme du bobineur ..... 28</p> <p>N. Mécanisme de coupe fill ..... 30</p> <p>P. Synchronisateur ..... 32</p> <p>Q. Mécanisme du boîtier de contrôle ..... 32</p> <p>R. Mécanisme de la pression d'air ..... 34</p>	<p>S. Mécanisme de l'équipement en alimentation électrique ..... 38</p> <p>T. Mécanisme de la système de contrôle du tissu ..... 40</p> <p>U. Mécanisme de la pédale ..... 56</p> <p>V. Mécanisme du plateau de la machine ..... 58</p> <p>W. Ensemble des pièces calibrées ..... 64</p> <p>X. Pièce optionnelle ..... 66</p> <p>X. Pièce optionnelle (tendeur pour pince) ..... 68</p> <p>X. Pièce optionnelle (éjecteur d'air) ..... 70</p> <p>Z1. Pièces fournies (avec la machine à coudre automatique) ..... 70</p> <p>Z2. Pièces fournies (avec le corps de la machine) ..... 72</p> <p>LISTE DES PIECES D'ECARTEMENT ..... 73</p> <p>INDEX ..... 78</p>
--	--

## Notas para usar este Manual de Piezas

1. Las piezas suministradas como conjuntos completos se enmarcan con una línea punteada .
2. Este libro ha sido compilado basándose en los datos de que se disponía en agosto 1989.
3. Las piezas quedan sujetas a cambios de diseño sin aviso previo.
4. De haber un simbolo \* junto al "Parts No. (Número de Pieza)", habrá que mirar la lista de piezas (lista de piezas calibradoras) de la página 73.

## INDICE

A. Cuerpo de la máquina .....	2	R. Mecanismo de la presión de aire .....	34
B. Mecanismo del eje superior .....	2	S. Mecanismo del equipo de alimentación de corriente .....	38
C. Mecanismo de oscilación de la barra de aguja .....	4	T. Mecanismo de la sistema de control de tela .....	40
D. Mecanismo del lanzador de barra de aguja .....	6	U. Mecanismo del pedal .....	56
E. Mecanismo del eje inferior .....	6	V. Mecanismo de la mesa de la máquina .....	58
F. Mecanismo del cuchillo .....	8	W. Conjunto de piezas calibradoras .....	64
G. Mecanismo del cangrejo .....	10	X. Pieza opcional .....	66
H. Lubricación .....	12	X. Pieza opcional (estirador de sisa) .....	68
J. Mecanismo de enhebrado .....	16	X. Pieza opcional (eyector de aire) .....	70
K. Mecanismo de liberador de tensión .....	18	Z1. Piezas accesorias (que vienen con la máquina de coser automática) .....	70
L. Mecanismo de apilador .....	20	Z2. Piezas accesorias (que vienen con el cuerpo de la máquina) .....	72
M. Mecanismo del devanador de la canilla .....	28	LISTA DE PIEZAS CALIBRADORAS .....	73
N. Mecanismo de recortadora de orillos .....	30	INDICE .....	78
P. Sincronizador .....	32		
Q. Mecanismo de la caja de controles .....	32		

A. 主体関係 / Machine body / Maschinengehäuse /  
 Corps de la machine / Cuerpo de la máquina

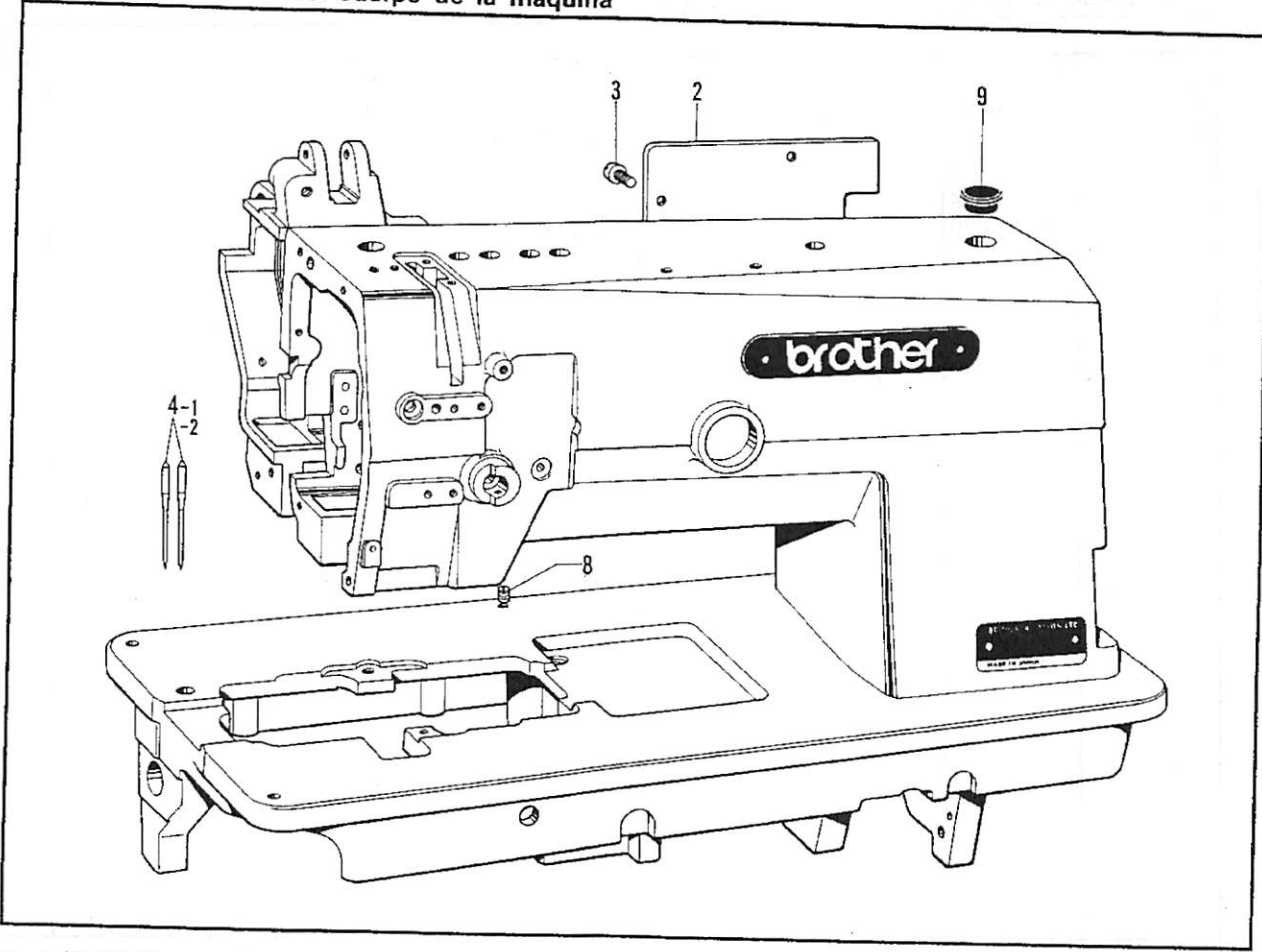

B. 上軸関係 / Upper shaft mechanism / Obere Welle /  
 Mécanisme de l'arbre supérieur / Mecanismo del eje superior

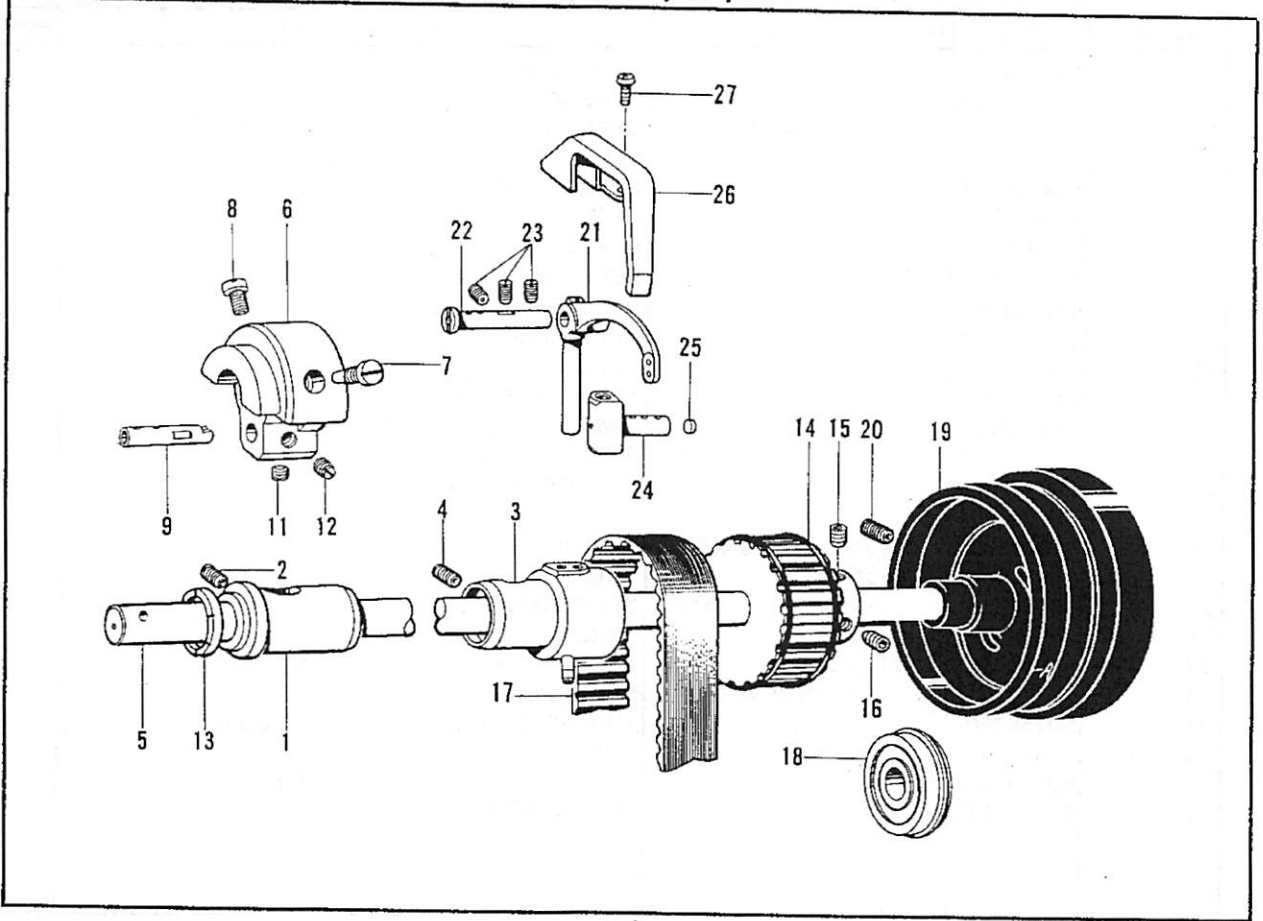

A. 主体関係/Machine body/Maschinengehäuse/  
Corps de la machine/Cuerpo de la máquina

REF.NO.	CODE	Q'TY	品名	NAME OF PARTS	RMKS
2	S14640001	1	カ"ワイタ	REAR COVER	
3	062680812	6	ナヘ"コ437-40X8	SCREW 437X8	
4-1	145646016	2	ミシンハリDPX17	NEEDLE DPX17 #16	
4-2	145646018	2	ミシンハリDPX17	NEEDLE DPX17 #18	
8	013719412	2	トメネジ"4.76クホ"ミ	SET SCREW 4.76	
9	159150000	1	カマシ"クメクラセン	OIL CAP	

B. 上軸関係/Upper shaft mechanism/Obere Welle/  
Mécanisme de l'arbre supérieur/Mecanismo del eje superior

REF.NO.	CODE	Q'TY	品名	NAME OF PARTS	RMKS
1	112573101	1	ウフシ"クメタルL	UPPER SHAFT BUSH (LEFT)	
2	013781012	1	トメネジ"6.35クホ"ミ	SET SCREW 6.35	
3	S07330101	1	ウフシ"クメタルMクミ	UPPER SHAFT BUSH (MIDDLE) ASSEMBLY	
4	013780710	1	トメネジ"6.35クホ"ミ	SET SCREW 6.35	
5	S14668001	1	ウフシ"ク	UPPER SHAFT	
6	149820000	1	テンビ"ンクランク	TAKE-UP CRANK	
7	100250001	1	シメネジ"7.14	SCREW 7.14	
8	146141001	1	アタマツキトメネジ"7.14	SET SCREW 7.14	
9	149821101	1	ハリホ"ウ克蘭ク	NEEDLE BAR CRANK	
11	101706001	1	トメネジ"6.35	SET SCREW 6.35	
12	100251001	1	トメネジ"6.35	SET SCREW 6.35	
13	112576001	1	テンビ"ンクランクリンク"	TAKE-UP CRANK RING	
14	180157001	1	タイミング"プーリ"Uクミ	TIMING PULLEY (UPPER) ASSEMBLY	
15	014771022	1	アタトメネジ"6.35クホ"ミ	SET SCREW 6.35	
16	016771032	1	アタト"リ635X10	SET SCREW 635X10	
17	112586001	1	タイミング"ヘルト	TIMING BELT	
18	158115001	1	タマシ"クウク6204ZZNR	BALL BEARING 6204ZZNR	
19	S07340001	1	プーリ	PULLEY	
20	S09670001	2	トメクホ"ミ595-28X14	SET SCREW 595X14	
21	S09253001	1	テンビ"ン	THREAD TAKE-UP LEVER	
22	S07334001	1	テンビ"ンシ"ク	THREAD TAKE-UP LEVER SHAFT	
23	013781012	3	トメネジ"6.35クホ"ミ	SET SCREW 6.35	
24	S07567001	1	テンビ"ンスヘ"リコ	THREAD TAKE-UP LEVER SLIDE BLOCK	
25	113024000	1	クミヒモフタ	PUSHER	
26	S07339001	1	テンビ"ンカバー	THREAD TAKE-UP LEVER COVER	
27	062670512	2	ナヘ"コ357-40X5	SCREW 357X5	



C. 針棒搖動關係 / Needle bar rocking mechanism / Nadelstangenbetätigung / Mécanisme de balancement de la barre à aiguille / Mecanismo de oscilación de la barra de aguja

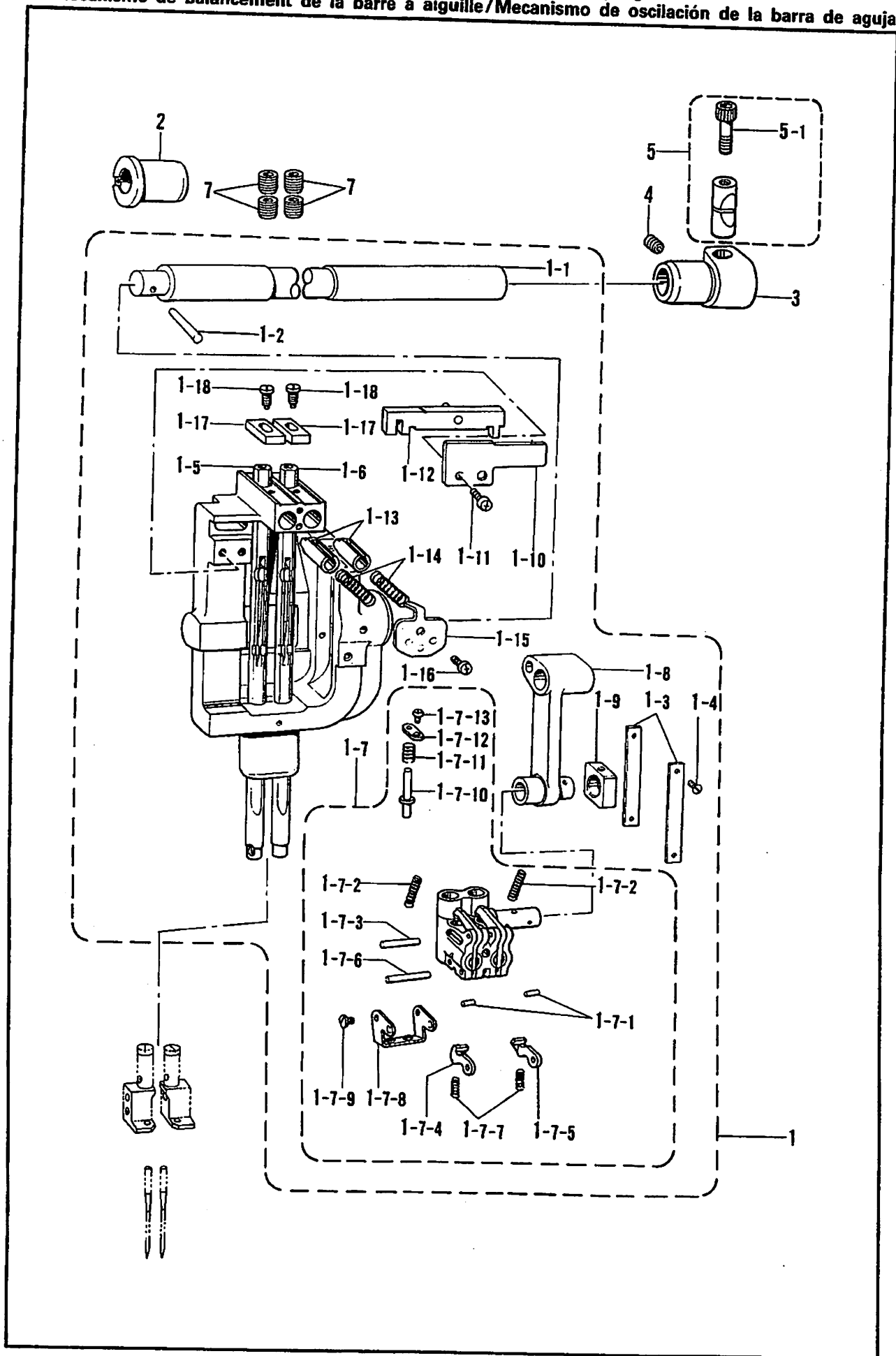

C. 針棒揺動関係/Needle bar rocking mechanism/Nadelstangenbetätigung/  
 Mécanisme de balancement de la barre à aiguille/Mecanismo de oscilación de la barra de aguja

REF.NO.	CODE	Q'TY	ヒンメイ	NAME OF PARTS	RMKS
1	S09162001	1	ハリボ"ウヨウト"ウシ"クミ	NEEDLE BAR ROCK SHAFT ASSEMBLY	
1-1	112588101	1	ハリボ"ウヨウト"ウシ"ク	NEEDLE BAR ROCK SHAFT	
1-2	107030001	1	テーパ"ピン	TAPER PIN	
1-3	112590001	2	ハリボ"ウアンナイイタ	GUIDE PLATE	
1-4	102731004	4	サラネシ"2.38	SCREW 2.38	
1-5	S09151001	1	ハリボ"ウLクミ(2.4MM)	NEEDLE BAR (LEFT) ASSEMBLY (2.4MM)	
1-6	S09149001	1	ハリボ"ウRクミ	NEEDLE BAR (RIGHT) ASSEMBLY	
1-7	*	1	ハリボ"ウタ"キクミ	NEEDLE BAR CLAMP ASSEMBLY	
1-7-1	149604001	2	ピン1.5X5.8	PIN 1.5X5.8	
1-7-2	149605001	2	クラッチテコハ"ネ	CLUTCH LEVER SPRING	
1-7-3	149827001	1	ピン2X15.8	PIN 2X15.8	
1-7-4	149606001	1	クラッチトメL	CLUTCH STOPPER (LEFT) ASSEMBLY	
1-7-5	149607001	1	クラッチトメR	CLUTCH STOPPER (RIGHT) ASSEMBLY	
1-7-6	149608001	1	ピン2X17.8	PIN 2X17.8	
1-7-7	112609001	2	スヘ"リイタストツハ"ハ"ネ	BED SLIDE STOPPER SPRING	
1-7-8	149609001	1	ハ"ネササエ	SPRING HOLDER	
1-7-9	100105005	2	シメネシ"2.38	SCREW 2.38	
1-7-10	149610001	1	リリースピン	RELEASE PIN	
1-7-11	149611101	1	リリースピンハ"ネ	RELEASE PIN SPRING	
1-7-12	149612101	1	リリースピンフタ	RELEASE PIN COVER	
1-7-13	114447002	1	シメネシ"2.38	SCREW 2.38	
1-8	149613001	1	ハリボ"ウクランクロツト"	NEEDLE BAR CRANK ROD	
1-9	150816001	1	ハリボ"ウレンカンカクコマ	NEEDLE BAR GUIDE SLIDE BLOCK	
1-10	S07574001	1	スヘ"リコアンナイイタ	SLIDE BLOCK GUIDE PLATE	
1-11	062670812	2	ナヘ"ユ357-40X8	SCREW 357X8	
1-12	*	1	スヘ"リコクミ	SLIDE BLOCK ASSEMBLY	
1-13	149621001	2	ハリボ"ウストツハ"	NEEDLE BAR STOPPER	
1-14	149622001	2	ハリボ"ウストツハ"ハ"ネ	NEEDLE BAR STOPPER SPRING	
1-15	149623001	1	ハ"ネフタ	SPRING COVER	
1-16	060660512	1	ハ"イント"318-40X5	SCREW 3.18X5	
1-17	149624001	2	ハリボ"ウマワリトメ	NEEDLE BAR ROTATE STOPPER	
1-18	149625001	2	シメネシ"3.18	SCREW 3.18	
2	112594001	1	ヨウト"ウシ"クメタルL	NEEDLE BAR ROCK SHAFT BUSH (LEFT)	
3	153012101	1	ヨウト"ウシ"クストツハ"	STOPPER	
4	013780710	1	トメネシ"6.35クボ"ミ	SET SCREW 6.35	
5	S09132001	1	ピンチスリーブ"クミ	PINCH SLEEVE ASSEMBLY	
5-1	018063022	1	アナボ"ルト6X30	BOLT 6X30	
7	014821022	4	アナトメネシ"7.94クボ"ミ	SET SCREW 7.94	

D. 針棒切換工操作關係/Needle bar flip-up mechanism/Nadelstangehochstellung/  
 Mécanisme de sautée de la barre à aiguille/Mecanismo del lanzador de barra de aguja

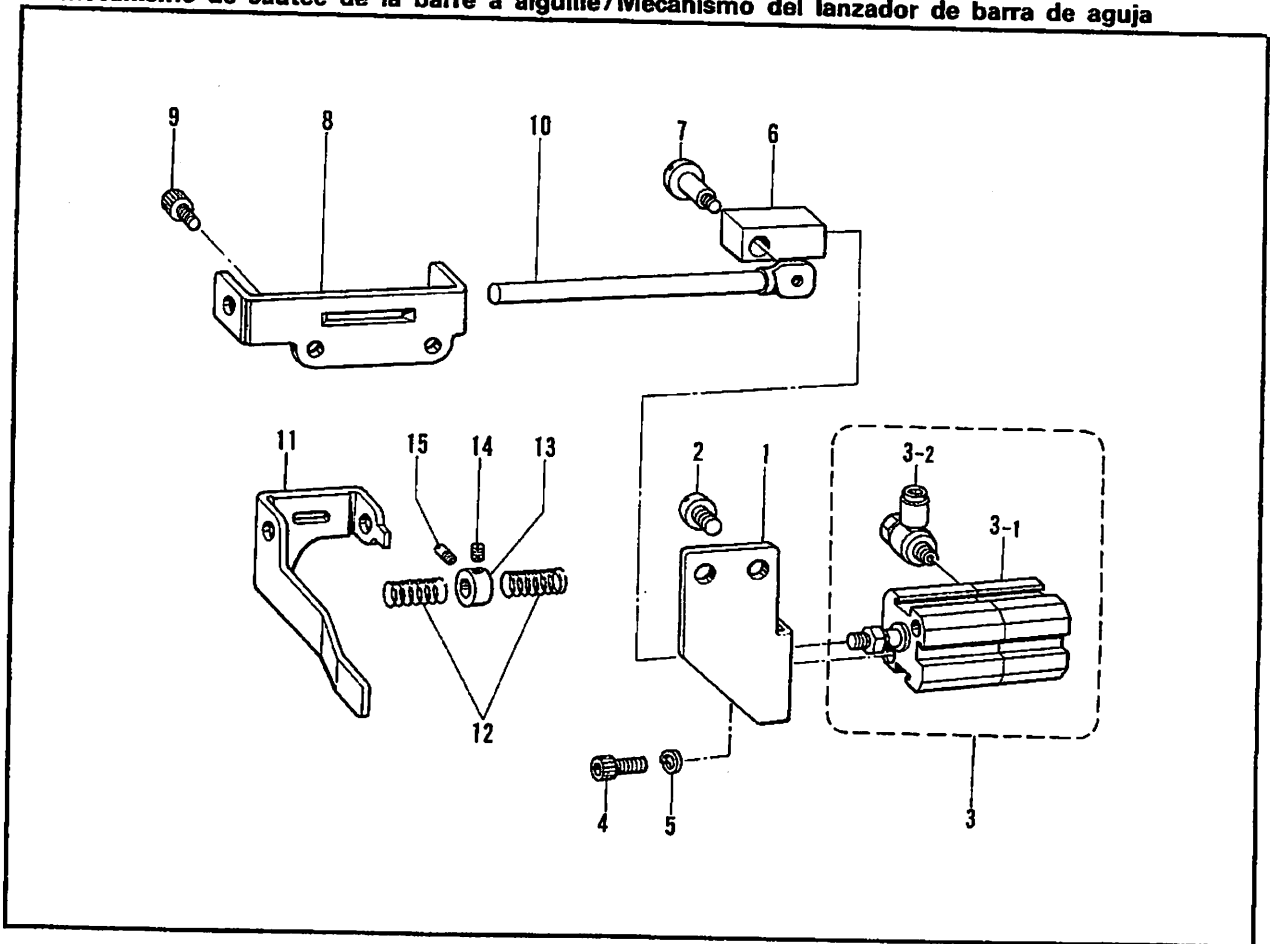

E. 下軸關係/Lower shaft mechanism/Untere Welle/  
 Mécanisme de l'arbre inférieur/Mecanismo del eje inferior

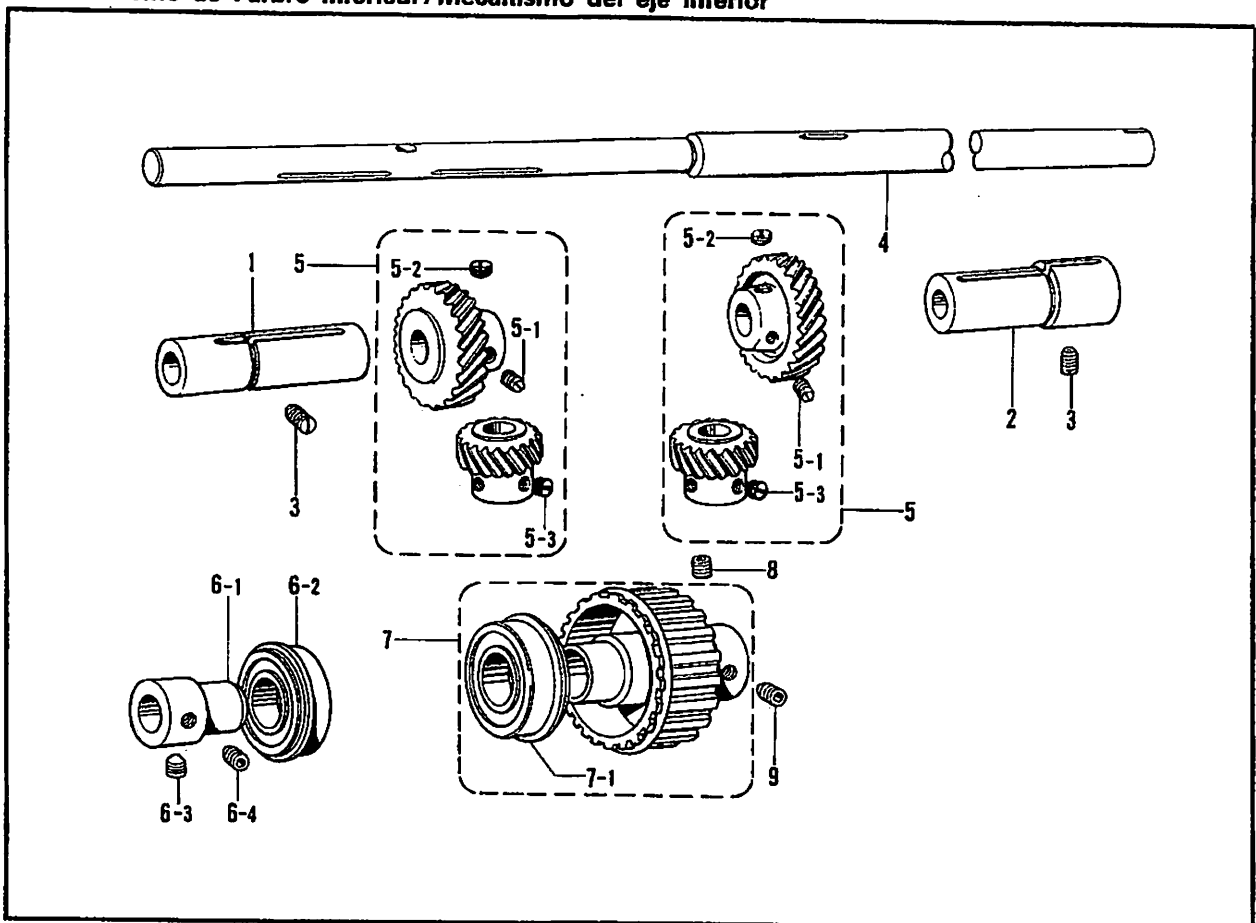

D. 針棒切換工操作関係/Needle bar flip-up mechanism/Nadelstangehochstellung/  
 Mécanisme de sauté de la barre à aiguille/Mecanismo del lanzador de barra de aguja

REF.NO.	CODE	Q'TY	ヒンメイ	NAME OF PARTS	RMKS
1	S14670001	1	キリカエヨウブ"ラケット	SELECTOR BRACKET	
2	062780812	2	ナヘ"コ635-28X8	SCREW 635X8	
3	S14672000	1	シリンダ"クミ	CYLINDER ASSEMBLY	
3-1	S14673000	1	シリンダ"12X5X5	CYLINDER 12X5X5	
3-2	S06883000	3	Sエルボ" M5-4	S-ELBOW M5-4	
4	018501022	2	アナボ"ルト5X10	BOLT 5X10	
5	028050242	2	ハ"ネザ"ガ"ネ2-5	SPRING WASHER 2-5	
6	S14671001	1	ツキ"テ	JOINT	
7	159732001	1	タ"ンネシ"4.37	STUD SCREW 4.37	
8	S16471001	1	スライト"シ"クウケ	SLIDE SHAFT SUPPORTER	
9	018680822	2	アナボ"ルト4.37X8	BOLT 4.37X8	
10	S14669001	1	スライト"シ"ク	SLIDE SHAFT	
11	S07586001	1	スライト"シ"クウケイタ	SLIDE SHAFT SUPPORTER PLATE	
12	149863001	2	シ"クウケイタハ"ネ	PLATE SPRING	
13	149864001	1	セツト"カラ-	SET COLLAR	
14	011679312	1	トメネシ"3.57ヒラ	SET SCREW 3.57	
15	149865001	1	アンナイネシ"	GUIDE SCREW	

E. 下軸関係/Lower shaft mechanism/Untere Welle/  
 Mécanisme de l'arbre inférieur/Mecanismo del eje inferior

REF.NO.	CODE	Q'TY	ヒンメイ	NAME OF PARTS	RMKS
1	S09287000	1	カマト"タ"イメタルL	ROTARY HOOK BASE BUSH (LEFT)	
2	S09288000	1	カマト"タ"イメタルR	ROTARY HOOK BASE BUSH (RIGHT)	
3	013781012	2	トメネシ"6.35クホ"ミ	SET SCREW 6.35	
4	S07439001	1	シタ"シ"ク	LOWER SHAFT	
5	S12445001	2	スパ"イラルキ"ヤクミA	SPIRAL GEAR ASSEMBLY (A)	
5-1	112684001	2	トメネシ"6.35	SET SCREW 6.35	
5-2	100251001	4	トメネシ"6.35	SET SCREW 6.35	
5-3	131007001	6	トメネシ"6.35クホ"ミ	SET SCREW 6.35	
6	S07446001	1	タマシ"クウケクミ	BALL BEARING ASSEMBLY	
6-1	S07447001	1	タマシ"クウケフ"ツシユ	BALL BEARING BUSH	
6-2	072600480	1	タマシ"クウケ6004ZZNR	BALL BEARING 6004ZZNR	
6-3	148821001	1	アナトメネシ"6.35トガ"リ	SET SCREW 6.35	
6-4	014771022	1	アナトメネシ"6.35クホ"ミ	SET SCREW 6.35	
7	S07442001	1	タイミンク"プ"ーリDクミ	TIMING PULLEY (D) ASSEMBLY	
7-1	158115001	1	タマシ"クウケ6204ZZNR	BALL BEARING 6204ZZNR	
8	014771022	1	アナトメネシ"6.35クホ"ミ	SET SCREW 6.35	
9	148821001	1	アナトメネシ"6.35トガ"リ	SET SCREW 6.35	

F. メス関係/Knife mechanism/Messer/  
 Mécanisme du couteau/Mecanismo del cuchillo

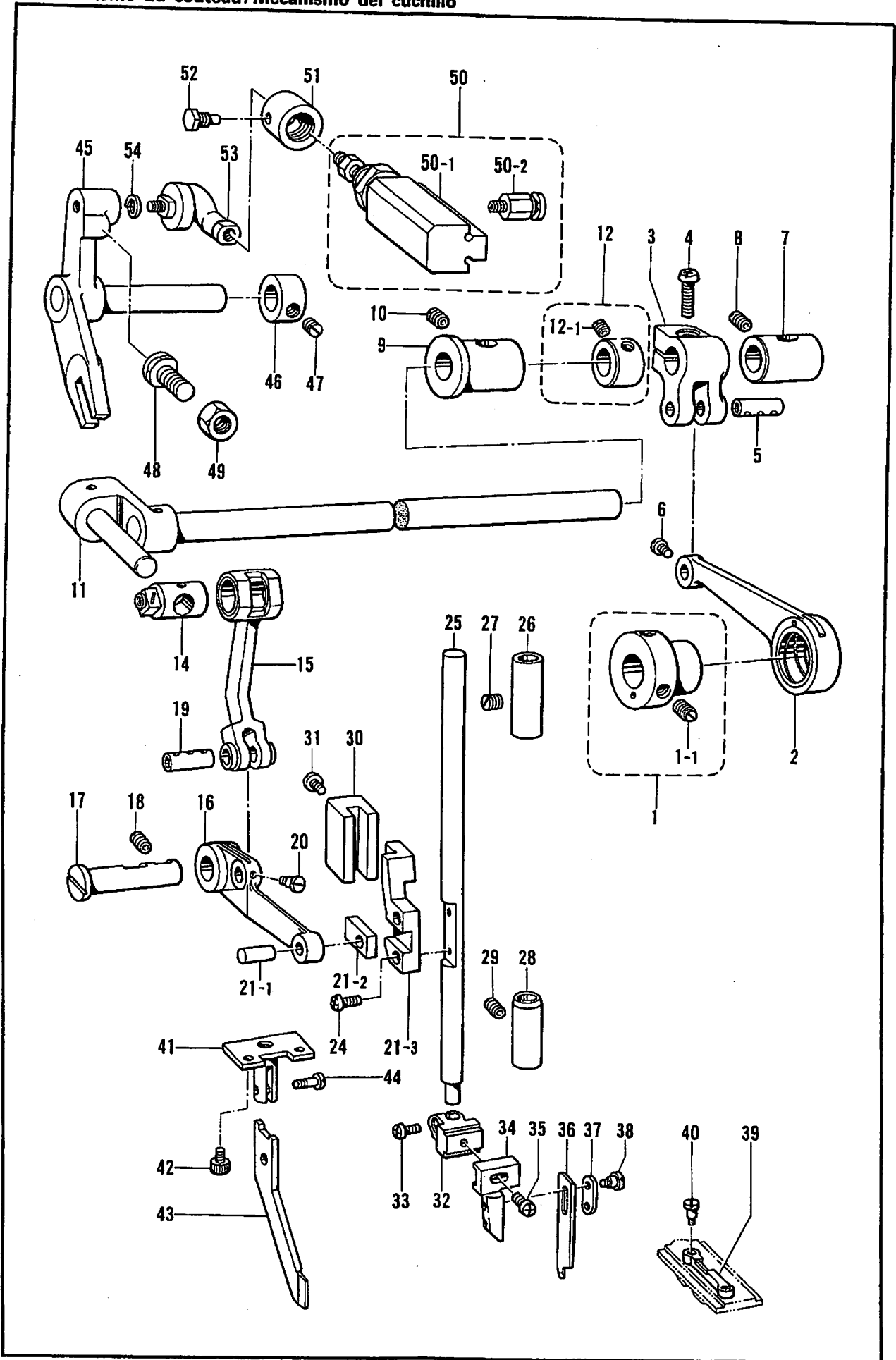

F. メス関係/Knife mechanism/Messer/  
Mécánisme du couteau/Mecanismo del cuchillo

REF.NO.	CODE	Q'TY	ヒンメイ	NAME OF PARTS	RMKS
1	153015001	1	クト"ウヘンジンリンネシ"ツキ	ECCENTRIC WHEEL WITH SCREW	
1-1	151604001	2	トメネシ"5.95	SET SCREW 5.95	
2	S14642001	1	クト"ウシ"クレンカン	CRANK SHAFT CONNECTING ROD	
3	S14674001	1	クト"ウシ"クウデ"	CRANK SHAFT ARM	
4	062751612	1	ナヘ"コ556-32X16	SCREW 556X16	
5	143625001	1	シ"ク6.35X17	STUD 6.35X17	
6	110563001	1	シメネシ"3.18	SCREW 3.18	
7	143626000	1	クト"ウシ"クメタルR	UPPER KNIFE ROCK SHAFT BUSH (RIGHT)	
8	013781012	1	トメネシ"6.35クホ"ミ	SET SCREW 6.35	
9	143627000	1	クト"ウシ"クメタルL	UPPER KNIFE ROCK SHAFT BUSH (LEFT)	
10	013781012	1	トメネシ"6.35クホ"ミ	SET SCREW 6.35	
11	S14643001	1	ヨウト"ウウデ"クミ	ROCKING ARM ASSEMBLY	
12	183677001	1	セツトカラー"ネシ"ツキ	SET COLLAR WITH SCREW	
12-1	100260001	2	トメネシ"5.95	SET SCREW 5.95	
14	S14647001	1	サト"ウレンカンスヘ"リコクミ	DRIVING CONNECTOR SLIDE BLOCK ASSEMBLY	
15	S14649001	1	サト"ウレンカン	DRIVING CONNECTOR	
16	S14650001	1	サト"ウレハ"ー	DRIVING LEVER	
17	S14651001	1	サト"ウレハ"ー"シ"ク	DRIVING LEVER SHAFT	
18	013781012	1	トメネシ"6.35クホ"ミ	SET SCREW 6.35	
19	143625001	1	シ"ク6.35X17	STUD 6.35X17	
20	110563001	1	シメネシ"3.18	SCREW 3.18	
21	183699001	1	メスホ"ウアンナイクミ	KNIFE BAR GUIDE ASSEMBLY	
21-1	143637001	1	シ"ク5.5X11	STUD 5.5X11	
21-2	143646000	1	メスホ"ウアンナイカクコマ	KNIFE BAR GUIDE BLOCK	
21-3	S14652001	1	メスホ"ウアンナイ	KNIFE BAR GUIDE	
24	062670812	2	ナヘ"コ357-40X8	SCREW 357X8	
25	S14653001	1	メスホ"ウ	KNIFE BAR	
26	S14654001	1	メスホ"ウメタルU	KNIFE BAR BUSH (UPPER)	
27	013781012	1	トメネシ"6.35クホ"ミ	SET SCREW 6.35	
28	S14655001	1	メスホ"ウメタルD	KNIFE BAR BUSH (LOWER)	
29	013781012	1	トメネシ"6.35クホ"ミ	SET SCREW 6.35	
30	S14656001	1	メスシ"クアンナイ	KNIFE SHAFT GUIDE	
31	062671012	2	ナヘ"コ357-40X10	SCREW 357X10	
32	S14657001	1	メスホルダ"ー	KNIFE HOLDER	
33	062670712	1	ナヘ"コ357-40X7	SCREW 357X7	
34	S14658001	1	メストリツケホ"ウ	KNIFE SETTING BAR	
35	112751003	1	シメネシ"3.57	SCREW 3.57	
36	153019001	1	ウフメス	UPPER KNIFE	
37	143641001	1	メスオサエイタ	UPPER KNIFE PRESSER	
38	143642101	2	メスオサエダ"ンネシ"	KNIFE PRESSER STUD SCREW	
39	153020001	1	コテイハ	FIXED KNIFE	
40	148539101	2	ダ"ンネシ"2.38	STUD SCREW 2.38	
41	S14659001	1	メスガ"イト"ホ"ウ	KNIFE GUIDE SHAFT	
42	S00208001	2	アナホ"ルト3.57X7	BOLT 3.57X7	
43	S14660001	1	ナカメスガ"イト"	INNER KNIFE GUIDE	
44	113050001	1	シメネシ"3.57	SCREW 3.57	
45	S14661001	1	キリカエレハ"ークミ	SELECTOR LEVER ASSEMBLY	
46	146581001	1	セツトカラー	SET COLLAR	
47	100260001	2	トメネシ"5.95	SET SCREW 5.95	
48	115585001	1	ホ"ルト7.94	BOLT 7.94	
49	152997001	1	ナツト7.94	NUT 7.94	
50	S14665000	1	シリンダ"クミ	CYLINDER ASSEMBLY	
50-1	S14666000	1	シリンダ"16X20	CYLINDER 16X20	
50-2	S04905000	2	ハーフユニオン	HALF UNION	
51	S14667001	1	シリンダ"クミ	CYLINDER ASSEMBLY	
52	140620001	2	シリンダ"ササエネシ"	CYLINDER SUPPORTING SCREW	
53	S08408000	1	リンクホ"ール	LINK BALL	
54	028050243	1	ハ"ネサ"ガ"ネ2-5	SPRING WASHER 2-5	

G. カマ関係/Rotary hook mechanism/Greifervorrichtung/  
 Mécanisme du crochet rotatif/Mecanismo del cangrejo

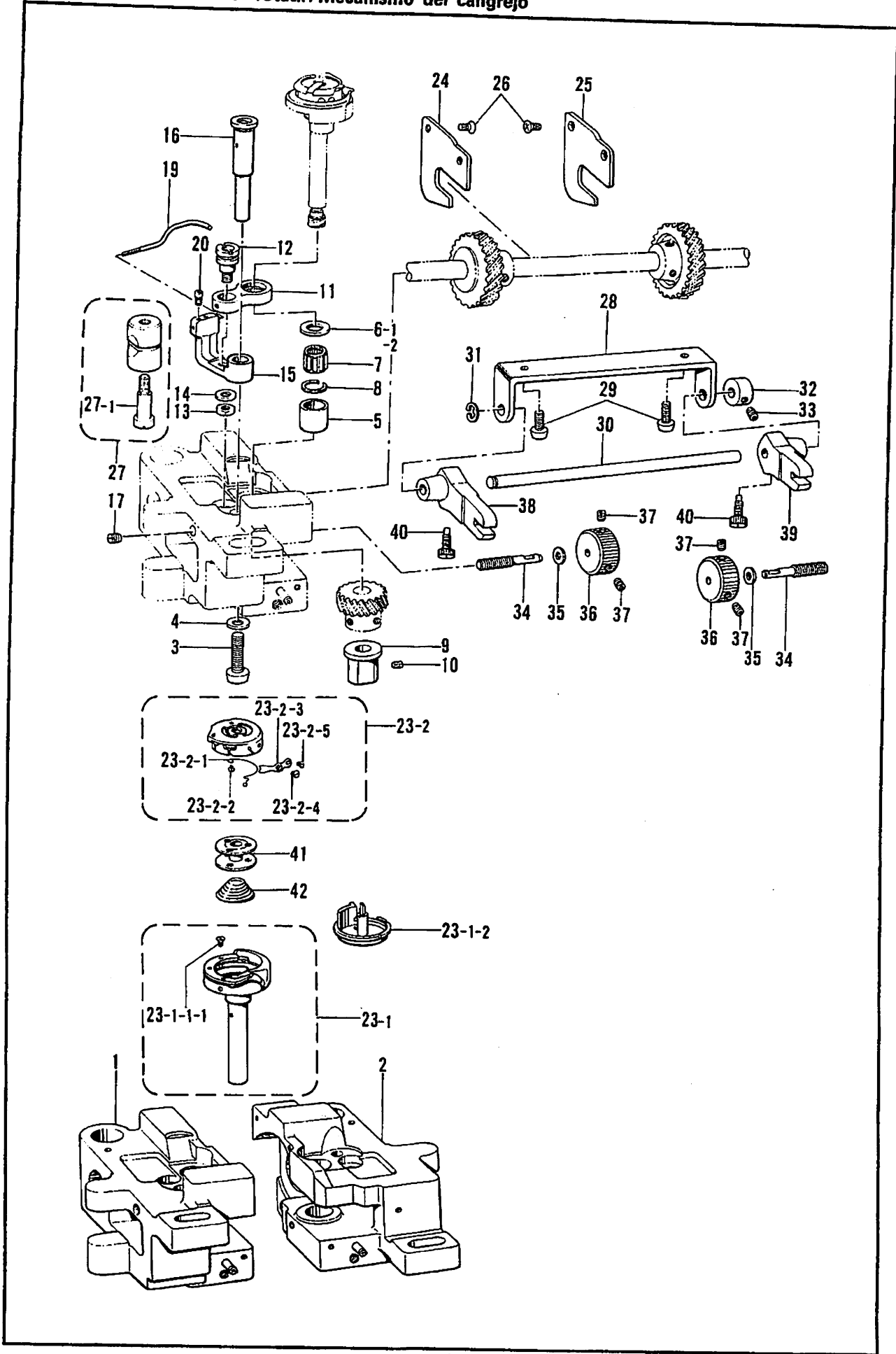

G. カマ関係/Rotary hook mechanism/Greifervorrichtung/  
Mécanisme du crochet rotatif/Mecanismo del cangrejo

REF.NO.	CODE	Q'TY	ヒンメイ	NAME OF PARTS	RMKS
1	S09255201	1	カマト"タ"イL	ROTARY HOOK BASE (LEFT)	
2	S15068101	1	カマト"タ"イR	ROTARY HOOK BASE (RIGHT)	
3	062782512	2	ナヘ"コ635-28X25	SCREW 635X25	
4	100197002	2	サ"ガ"ネ	WASHER	
5	S09259001	2	カマシ"クメタルU	ROTARY HOOK SHAFT BUSH (UPPER)	
6-1	S09260001	2	スラストリング"A(1.2MM)	THRUST RING (A)(1.2MM)	
6-2	S09261001	2	スラストリング"B(1.4MM)	THRUST RING (B)(1.4MM)	
7	S07420000	2	ニードル"ルハ"アリング"	NEEDLE BEARING	
8	S07419001	2	ストップ"リング"	STOP RING	
9	S07417001	2	カマシ"クメタルD	ROTARY HOOK SHAFT BUSH (LOWER)	
10	013710512	2	トメネシ"4.76クホ"ミ	SET SCREW 4.76	
11	150967101	2	オープナー"リンク"	OPENER LINK	
12	148005001	2	オープナー"リンク"シ"ク	OPENER LINK STUD	
13	110161006	2	ナツト4.76	NUT 4.76	
14	025710232	2	ヒラサ"カ"ネチユウ4.76	PLAIN WASHER 4.76	
15	S09262101	2	オープナー"レハ"ー	OPENER LEVER	
16	S13021001	2	オープナー"レハ"ーシ"ク	OPENER LEVER SHAFT	
17	013711012	2	トメネシ"4.76クホ"ミ	SET SCREW 4.76	
19	S07423101	2	オープナー	OPENER	
20	S07424001	4	トメネシ"3.18	SET SCREW 3.18	
23	S09265001	2	ニホンハリカマ	TWIN NEEDLE ROTARY HOOK ASSEMBLY	
23-1	S13616001	2	カマクミ	ROTARY HOOK ASSEMBLY	
23-1-1	S09267001	2	ソトカマクミ	OUTER ROTARY HOOK ASSEMBLY	
23-1-1-1	151027001	4	ウチカマオサエトメネシ"	INNER ROTARY HOOK SET SCREW	
23-1-2	S09274001	2	ウチカマクミ	INNER ROTARY HOOK ASSEMBLY	
23-2	S09279001	2	キヤツブ"クミ	CAP ASSEMBLY	
23-2-1	155478001	2	シタイトタルミトリハ"ネ	SPRING	
23-2-2	151035001	2	タルミトリハ"ネトメネシ"	SET SCREW	
23-2-3	155479001	2	チヨウシハ"ネ	TENSION ADJUSTING SPRING	
23-2-4	151029001	2	チヨウシネシ"	TENSION ADJUSTING SCREW	
23-2-5	151030001	2	チヨウシハ"ネトメネシ"	SET SCREW	
24	S07436001	1	キ"ヤアンナイL	GEAR GUIDE (LEFT)	
25	S07437001	1	キ"ヤアンナイR	GEAR GUIDE (RIGHT)	
26	108960002	4	サラネシ"3.57	SCREW 3.57	
27	S07658001	2	ピンチスリーブ"クミ	PINCH SLEEVE ASSEMBLY	
27-1	112700001	2	シメネシ"5.95	SCREW 5.95	
28	S07430001	1	ハリスキチヨウセツホ"ウササエ	ADJUSTING BAR SUPPORTER	
29	062711012	2	ナヘ"コ476-32X10	SCREW 476X10	
30	S07431001	1	ハリスキチヨウセツホ"ウ	ADJUSTING BAR	
31	048040342	1	トメワE4	STOP RING E4	
32	159436001	1	セツトカラー	SET COLLAR	
33	014680622	1	アナトメネシ"4.37クホ"ミ	SET SCREW 4.37	
34	S07434001	2	ハリスキチヨウセツネシ"	ROTARY HOOK BASE ADJUSTING SCREW	
35	025680132	2	ヒラサ"カ"ネシヨウ4.37	PLAIN WASHER 4.37	
36	S07435001	2	ハリスキチヨウセツナツト	ROTARY HOOK BASE ADJUSTING DIAL	
37	014680622	4	アナトメネシ"4.37クホ"ミ	SET SCREW 4.37	
38	S07432001	1	ハリスキチヨウセツフタマタL	ADJUSTING FORKED LEVER (LEFT)	
39	S07433001	1	ハリスキチヨウセツフタマタR	ADJUSTING FORKED LEVER (RIGHT)	
40	131226001	2	ハリトメネシ"3.57	NEEDLE SET SCREW 3.57	
41	S09285001	2	ホ"ビ"ン	BOBBIN	
42	156557001	2	クウテンホ"ウシハ"ネ	BOBBIN TENSION SPRING	



H. 給油潤滑關係/Lubrication/Schmierung/  
Lubrification/Lubricación

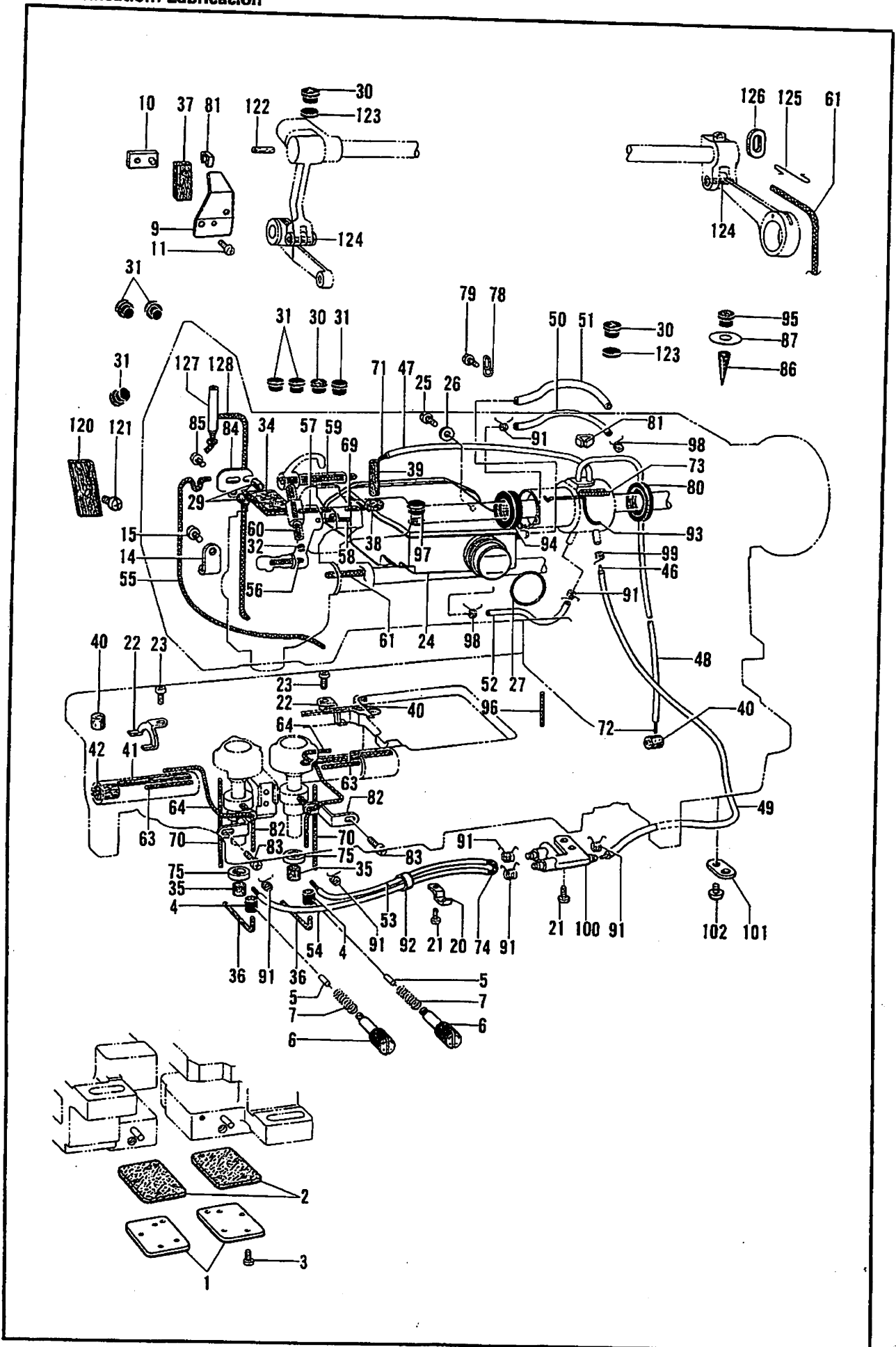

H. 給油潤滑関係/Lubrication/Schmierung/  
Lubrification/Lubrificación

REF.NO.	CODE	QTY	品名	NAME OF PARTS	RMKS
1	S07448001	2	カマト"タ"イフタ	ROTARY HOOK BASE COVER	
2	S07449000	2	カマト"タ"イハ"ツキン	ROTARY HOOK BASE PACKING	
3	062670812	8	ナヘ"コ357-40X8	SCREW 357X8	
4	S07477000	2	ゴムリング	RUBBER RING	
5	S07478000	2	ゴムオサエ	RUBBER PRESSER	
6	S07479101	2	オイルチヨウセツネジ"	OIL ADJUSTING SCREW	
7	S16114001	2	オイルチヨウセツハ"ネ	OIL ADJUSTING SCREW	
9	112716101	1	オイルヨクイタ	OIL STOPPER PLATE	
10	112717001	1	オイルヨクイタオサエカネ	OIL STOPPER PLATE PRESSER	
11	062711012	1	ナヘ"コ476-32X10	SCREW 476X10	
14	112739001	2	クミヒモササエ	WICK SUPPORTER	
15	062670512	2	ナヘ"コ357-40X5	SCREW 357X5	
20	142268001	1	コード"オサエL	CORD HOLDER (LARGE)	
21	062670512	3	ナヘ"コ357-40X5	SCREW 357X5	
22	S07471001	2	ヒモササエ	WICK HOLDER	
23	062670512	2	ナヘ"コ357-40X5	SCREW 357X5	
24	S07450100	1	オイルタンククミ	OIL TANK ASSEMBLY	
25	062711012	2	ナヘ"コ476-32X10	SCREW 476X10	
26	025710232	2	ヒラサ"カ"ネチユウ4.76	PLAIN WASHER 4.76	
27	081030070	1	Oリング" P30	O RING P30	
29	107155001	2	フェルト	FELT	
30	140890001	3	オイルカツプ	OIL CAP	
31	104821001	6	メクラセン	OIL CAP	
32	142274001	2	メクラセン	OIL CAP	
34	149834000	1	フェルト	FELT	
35	151927001	2	クラッチフェルト	CLUTCH FELT	
36	S07476000	2	フェルト	FELT	
37	148762001	1	デンヒ"ンフェルト	FELT	
38	112734001	1	ウワシ"クメタルLフェルト	UPPER SHAFT BUSH (LEFT) FELT	
39	S07571000	1	フェルト	FELT	
40	112753001	3	フェルト	FELT	
41	113362001	2	カマト"タ"イメタルRフェルト	ROTARY HOOK BASE BUSH (RIGHT) FELT	
42	115249001	1	フェルト	FELT	
46	S07460100	1	ワイヤー	WIRE	
47	S07453000	1	ヒ"ニールチューブ"	OIL TUBE	
48	S07454000	1	ヒ"ニールチューブ"	OIL TUBE	
49	S07455100	1	ヒ"ニールチューブ"	OIL TUBE	
50	S07456000	1	ヒ"ニールチューブ"	OIL TUBE	
51	S07457100	1	ヒ"ニールチューブ"	OIL TUBE	
52	S07810000	1	ヒ"ニールチューブ"	OIL TUBE	
53	S07458100	1	ヒ"ニールチューブ"	OIL TUBE	
54	S07459100	1	ヒ"ニールチューブ"	OIL TUBE	
55	150374000	1	クミヒモ	WICK (20CM)	
56	112728001	1	クミヒモ	WICK (5CM)	
57	114693001	1	クミヒモ	WICK (3CM)	
58	112735000	1	クミヒモ	WICK (4.5CM)	
59	113653000	1	クミヒモ	WICK (13CM)	
60	S03289001	1	クミヒモ4X4	WICK 4X4 (4CM)	
61	112736000	1	クミヒモ	WICK (44CM)	
63	S07461000	2	クミヒモ	WICK (3.2CM)	
64	108802001	2	クミヒモ4X4	WICK 4X4 (25CM)	
69	S07462000	1	クミヒモ	WICK (2.5CM)	
70	S07463000	2	クミヒモ	WICK (7CM)	
71	153920001	1	クミヒモ4X4	WICK 4X4 (30CM)	
72	152974001	1	クミヒモ4X4	WICK 4X4 (35CM)	
73	S03289001	1	クミヒモ4X4	WICK 4X4 (4CM)	
74	S07464100	1	クミヒモ	WICK	
75	156070002	2	スヘ"サー	SPACER	
78	S07467001	1	チューブ"ササエ	TUBE HOLDER	
79	062680812	1	ナヘ"コ437-40X8	SCREW 437X8	
80	S07468000	1	オイルシール	OIL SEAL	
81	S07469001	2	チューブ"カシメ	WICK CHOKE PLATE	

H. 給油潤滑關係 / Lubrication / Schmierung /  
Lubrification / Lubricación

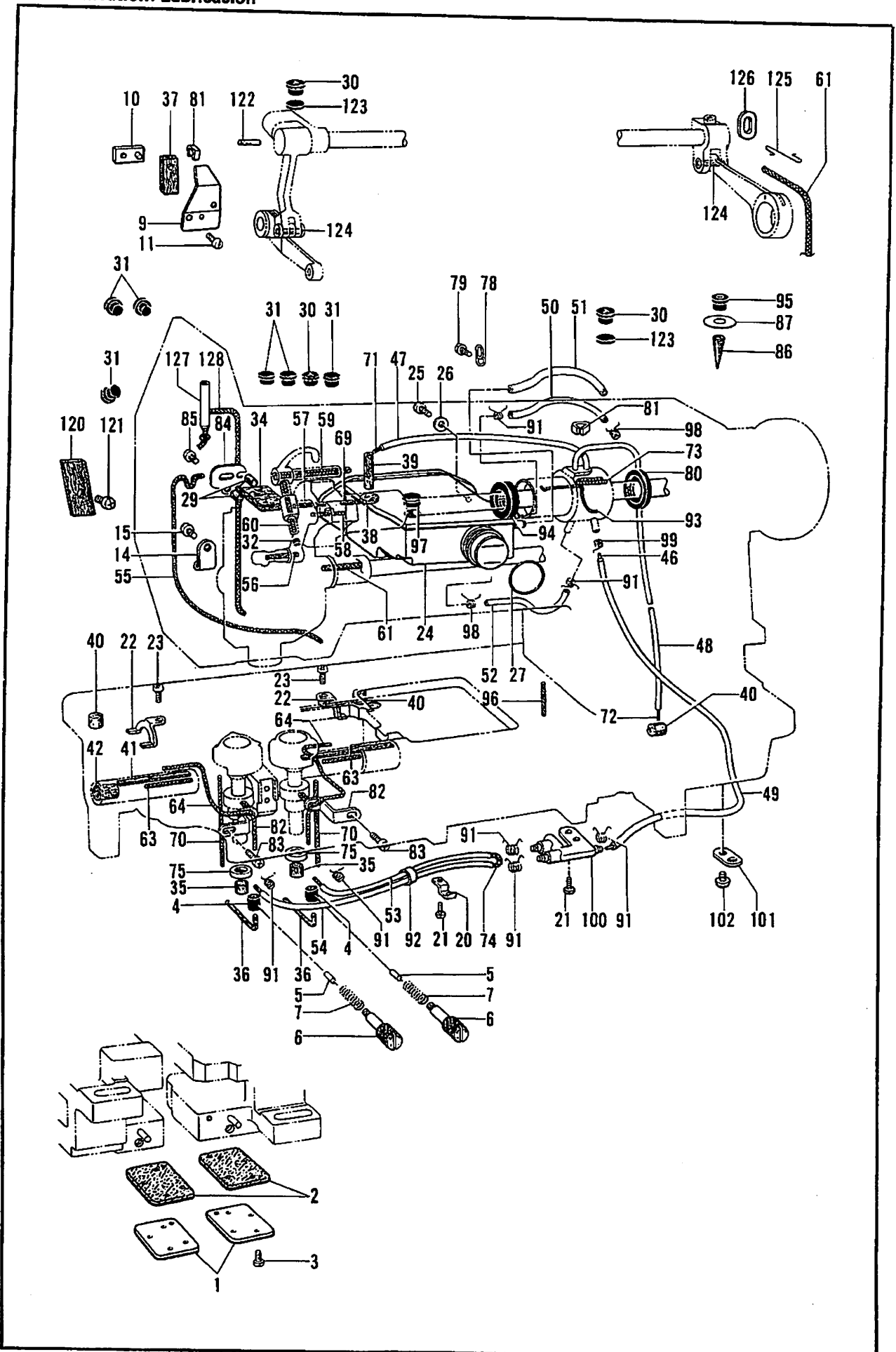

H. 給油潤滑関係 / Lubrication / Schmierung /  
Lubrification / Lubricación

REF.NO.	CODE	QTY	ヒンメイ	NAME OF PARTS	RMKS
82	S07470001	2	クミヒモササエ	WICK HOLDER	
83	062670512	2	ナヘ"コ357-40X5	SCREW 357X5	
84	149626001	1	クミヒモフタ	WICK COVER	
85	060660512	1	ハ"イント"318-40X5	SCREW 3.18X5	
86	S07473000	1	オイルフィルター	OIL FILTER	
87	S07481000	1	オイルシート	OIL SEAT	
91	S07876001	7	チューブ"ストツパー	TUBE CLAMP	
92	146253000	1	チューブ"	TUBE	
93	S09369000	1	クミヒモ	WICK (7CM)	
94	S09364000	1	オイルシール	OIL SEAL	
95	112758001	1	ハ"ット"オイルフタ	OIL CAP	
96	111191001	1	クミヒモ	WICK (3.5CM)	
97	104821001	1	メクラセン	OIL CAP	
98	S07876001	2	チューブ"ストツパー	TUBE STOPPER	
99	S07876001	1	チューブ"ストツパー	TUBE STOPPER	
100	S14189000	1	ターミナル	TERMINAL	
101	146536001	1	オクリホ"タンジ"クササエ	FEED ADJUSTING SHAFT SUPPORTER	
102	062670512	1	ナヘ"コ357-40X5	SCREW 357X5	
120	143679000	1	フェルト	FELT	
121	060670612	1	ハ"イント"357-40X6	SCREW 357X6	
122	153024000	1	クミヒモ	WICK	
123	143936000	2	フェルト	FELT	
124	112293001	2	ハリホ"ウリンクシ"クフェルト	FELT	
125	116795000	1	クリツプ"	CLIP	
126	143676000	1	レンカンオイルキリ	OIL SEAL	
127	S14685001	1	パイプ	PIPE	
128	152974001	1	クミヒモ4X4	WICK 4X4 (35CM)	

J. 糸通シ関係 / Threading mechanism / Fadenführungs-vorrichtung /  
 Mécanisme de l'enfilage / Mecanismo de enhebrado

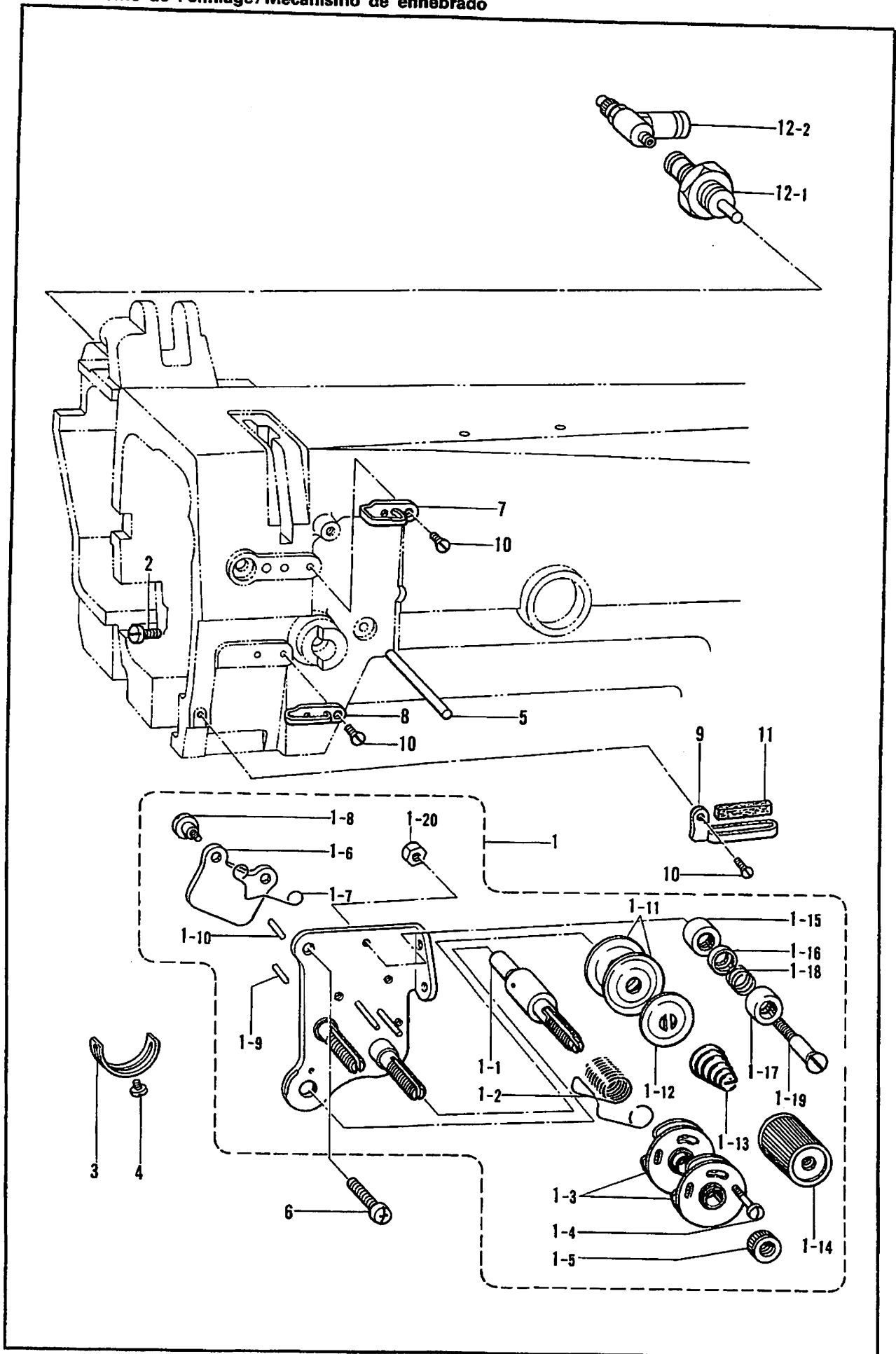

J. 糸通シ関係/Threading mechanism/FadenführungsVorrichtung/  
 Mécanisme de l'enfilage/Mecanismo de enhebrado

REF.NO.	CODE	QTY	品名	NAME OF PARTS	RMKS
1	S07489101	1	ウワイトチヨウシクミ	NEEDLE THREAD TENSION ASSEMBLY	
1-1	144680001	1	チヨウシシク	TENSION STUD	
1-2	155491001	1	イトトリハネ	THREAD TAKE-UP SPRING	
1-3	108254001	2	イトトリハネアンナイクミ	SPRING GUIDE ASSEMBLY	
1-4	144682001	1	シメネジ"2.38	SCREW 2.38	
1-5	108265001	1	イトチヨウシナツト	TENSION NUT	
1-6	S07487001	1	イトユルメイタ	TENSION RELEASE PLATE	
1-7	118320001	1	イトユルメハネ	TENSION RELEASE SPRING	
1-8	112712001	2	ダ"ネジ"3.57	STUD SCREW 3.57	
1-9	158769001	1	イトユルメピンR	TENSION RELEASE PIN (RIGHT)	
1-10	S07488001	1	イトユルメピンL	TENSION RELEASE PIN (LEFT)	
1-11	145446001	4	イトチヨウシサラ	TENSION DISC	
1-12	159805001	2	イトチヨウシサラオサエ	TENSION DISC PRESSER	
1-13	S07490001	2	イトチヨウシハネ	TENSION SPRING	
1-14	149566002	2	イトチヨウシナツト	TENSION NUT	
1-15	144685001	2	イトアンナイフタ	THREAD GUIDE CAP	
1-16	144686001	2	イトアンナイサラ	THREAD GUIDE DISC	
1-17	144687001	2	イトアンナイダ"イ	THREAD GUIDE BRACKET	
1-18	144688001	2	イトアンナイハネ	THREAD GUIDE SPRING	
1-19	144689001	2	イトアンナイダ"ンネジ"	THREAD GUIDE STUD SCREW	
1-20	021670102	2	ナツト1 シユ3.57	NUT 3.57	
2	100064002	1	シメネジ"3.57	SCREW 3.57	
3	112709001	1	イトトリハネストツハ"	STOPPER	
4	062670512	1	ナヘ"コ357-40X5	SCREW 357X5	
5	S14677001	1	イトユルメシク	THREAD RELEASE SHAFT	
6	062680812	1	ナヘ"コ437-40X8	SCREW 437X8	
7	108266001	1	アームイトアンナイU	ARM THREAD GUIDE (UPPER)	
8	112658001	1	アームイトアンナイM	ARM THREAD GUIDE (MIDDLE)	
9	112715001	1	アームイトアンナイD	ARM THREAD GUIDE (LOWER)	
10	108960002	3	サラネジ"3.57	SCREW 3.57	
11	114941001	1	アームイトアンナイフェルト	FELT	
12	S15096000	1	シリンダ"クミ	CYLINDER ASSEMBLY	
12-1	S15097000	1	シリンダ"10X5	CYLINDER 10X5	
12-2	S15871000	1	スピコンツキ"テM5-4	SPEED CONTROLLER JOINT M5-4	

K. 糸ユルメ関係/Tension release mechanism/ Spannungsverminderungs-vorrichtung/  
Mécánisme de relâche de tension/Mecanismo de liberador de tensión

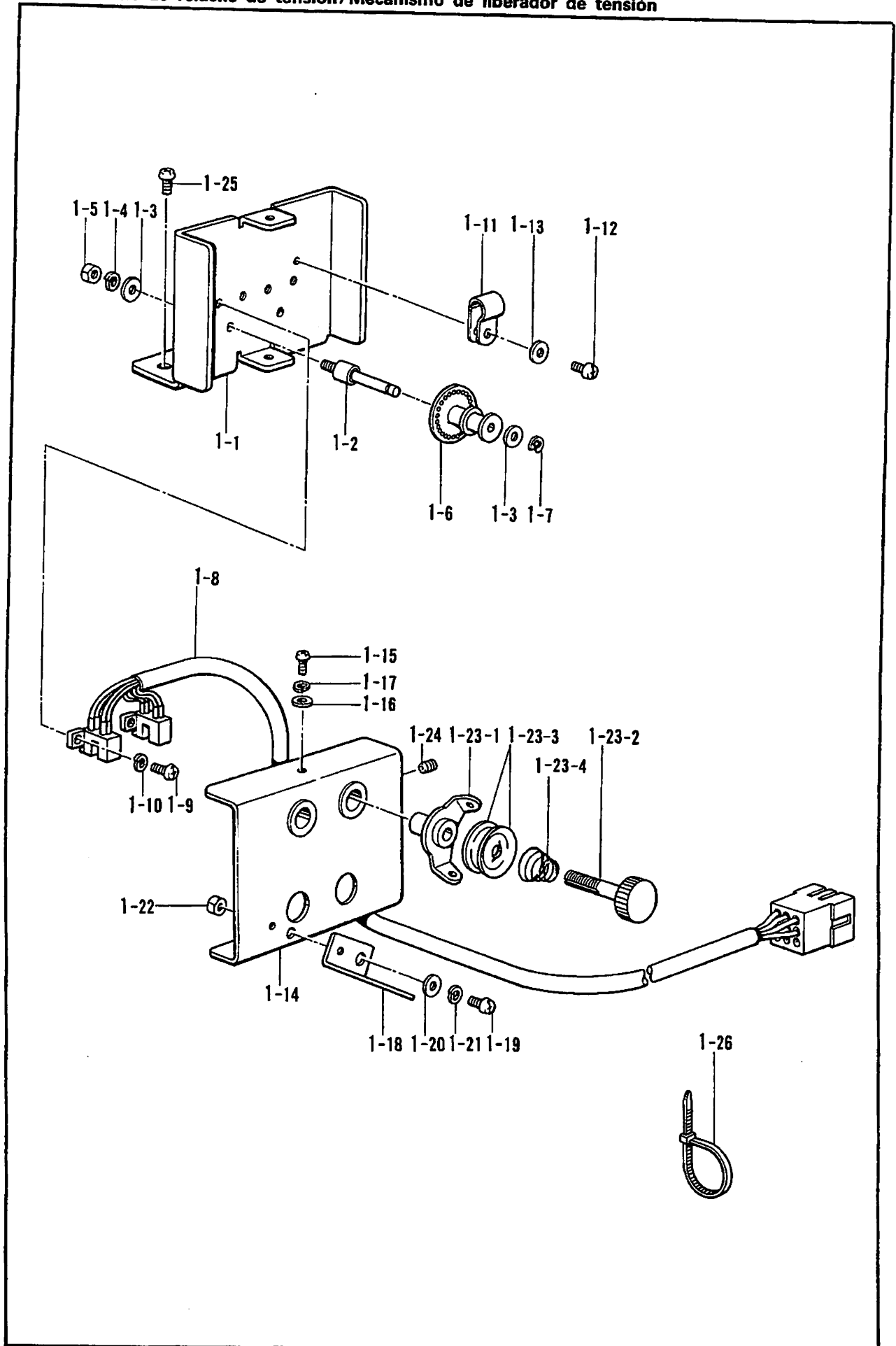

K. 糸ユルメ関係/Tension release mechanism/Spannungsverminderungsvoerrichtung/  
Mecanisme de relâche de tension/Mecanismo de liberador de tension

REF.NO.	CODE	Q'TY	ヒンメイ	NAME OF PARTS	RMKS
1	S09399001	1	ウフイキレケンチクミ	UPPER THREAD BREAKAGE SENSOR ASSEMBLY	
1-1	S09400001	1	トリツケタイ	SETTING BRACKET	
1-2	S09401001	2	シテンシク	FULCRUM SHAFT	
1-3	025030233	4	ヒラサ"カ"ネチユウ3	PLAIN WASHER 3	
1-4	028030243	2	ハ"ネサ"カ"ネ2-3	SPRING WASHER 2-3	
1-5	021300103	2	1シユナツト3	NUT 3	
1-6	S09402001	2	プーリー	PULLEY	
1-7	048020342	2	トメワE2	STOP RING E2	
1-8	S08117000	1	イトキレセンサークミ	THREAD BREAKAGE SENSOR ASSEMBLY	
1-9	062300616	4	ナヘ"コM3X6	SCREW M3X6	
1-10	028030243	4	ハ"ネサ"カ"ネ2-3	SPRING WASHER 2-3	
1-11	S00480000	1	コード"ホルタ" #5	CORD HOLDER (5N)	
1-12	062400616	1	ナヘ"コM4X6	SCREW M4X6	
1-13	025040233	1	ヒラサ"カ"ネチユウ4	PLAIN WASHER 4	
1-14	S09403001	1	カバー	COVER	
1-15	062300616	2	ナヘ"コM3X6	SCREW M3X6	
1-16	025030233	2	ヒラサ"カ"ネチユウ3	PLAIN WASHER 3	
1-17	028030243	2	ハ"ネサ"カ"ネ2-3	SPRING WASHER 2-3	
1-18	S03566001	1	メンタイトカケ	FACE PLATE THREAD GUIDE	
1-19	062400806	1	ナヘ"コ4X8	SCREW 4X8	
1-20	025040233	1	ヒラサ"カ"ネチユウ4	PLAIN WASHER 4	
1-21	028040243	1	ハ"ネサ"カ"ネ2-4	SPRING WASHER 2-4	
1-22	021400202	1	2シユナツト4	NUT 4	
1-23	183377001	2	プレテンションクミA	PRE-TENSION ASSEMBLY (A)	
1-23-1	S02611001	2	イトアンナイ	THREAD GUIDE	
1-23-2	S02612001	2	イトアンナイチヨウシホ"ウ	PRE-TENSION STUD	
1-23-3	144504001	2	イトアンナイサラ	THREAD GUIDE DISC	
1-23-4	154560001	2	プレテンションハ"ネA	PRE-TENSION SPRING (A)	
1-24	014500522	2	アナトメネシ"5クホ"ミ	SET SCREW 5	
1-25	062761412	2	ナヘ"コ595-28X14	SCREW 595X14	
1-26	S04557000	1	バンドタイPLTIM	BAND PLTIM	



L. スタッカー関係/Stacker mechanism/Anhäufung/  
 Mécanisme de l'empileur/Mecanismo de apilador

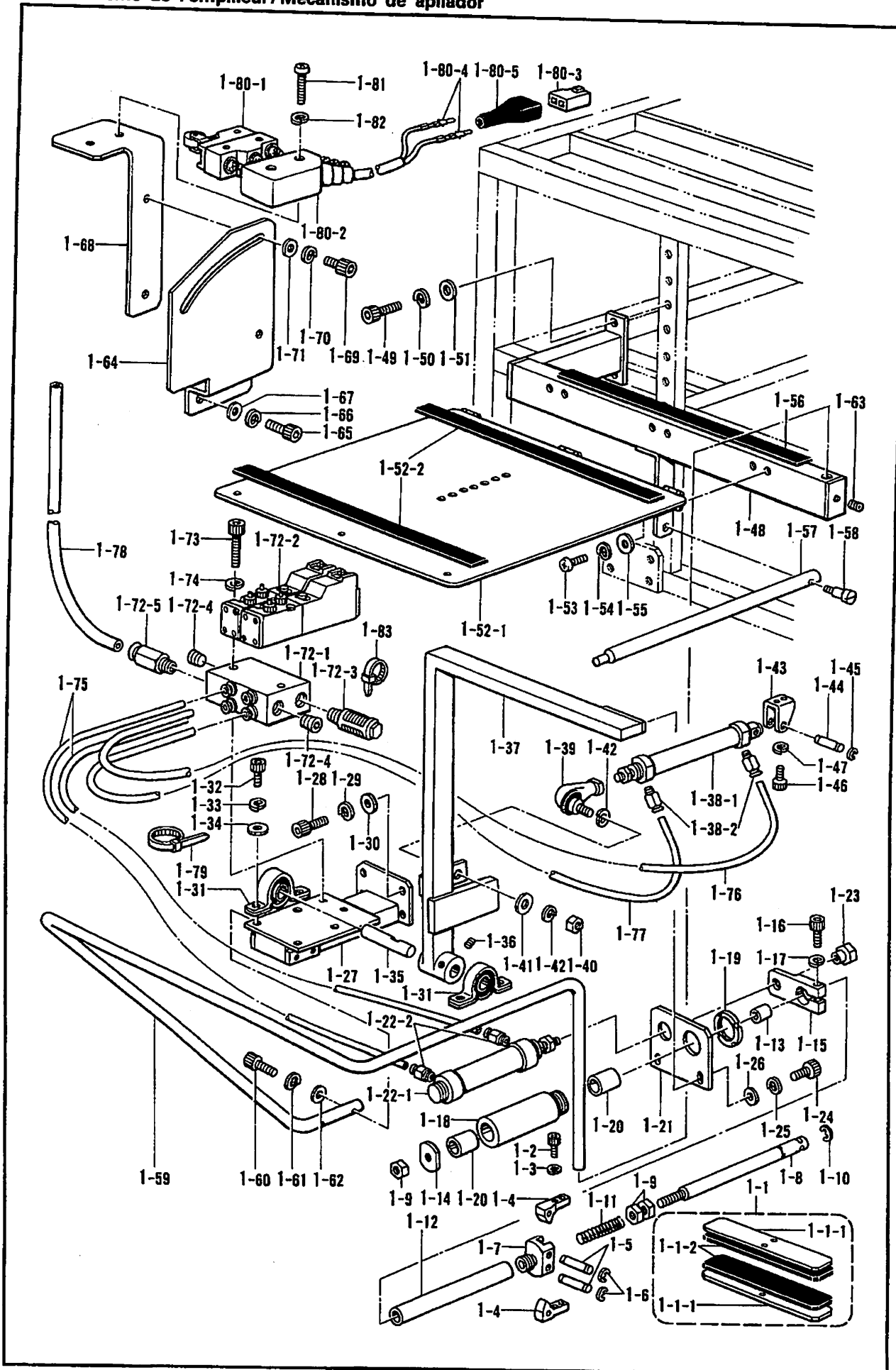

L. スタッカ-関係/Stacker mechanism/Anhäufung/  
Mécanisme de l'empileur/Mecanismo de apilador

REF.NO.	CODE	QTY	ヒンメイ	NAME OF PARTS	RMKS
1	S08431101	1	ツカミスタッカ-クミ	PICK-UP TYPE STACKER ASSEMBLY	
1-1	S08363001	2	チャックアダマクミ	CHUCK HOLDER ASSEMBLY	
1-1-1	S08432001	2	チャックアダマ	CHUCK HOLDER	
1-1-2	S08433000	2	チャックゴム	CHUCK RUBBER	
1-2	018401022	4	アナホ"ルト4X10	BOLT 4X10	
1-3	028040242	4	ハ"ネサ"カ"ネチユウ4	SPRING WASHER 2-4	
1-4	S08434001	2	チャック	CHUCK	
1-5	S08435001	2	シデンシ"ク	FULCRUM SHAFT	
1-6	048030342	4	トメワE3	STOP RING E3	
1-7	S08436001	1	チャックホルダ"	CHUCK HOLDER	
1-8	S08437001	1	カイヘイシ"ク	OPENING AND CLOSING MOTION SHAFT	
1-9	021080206	3	2シユナツト8	NUT 8	
1-10	048070342	1	トメワE7	STOP RING E7	
1-11	S08438001	1	アツシユクハ"ネ	PRESSURE SPRING	
1-12	S08439001	1	スライト"シ"ク	SLIDE SHAFT	
1-13	S08440000	1	ト"ライヘ"アリンク"	DRY BEARING	
1-14	S08441001	1	ストツハ"	STOPPER	
1-15	S08442001	1	レンケツイタ	CONNECTING PLATE	
1-16	018502022	1	アナホ"ルト5X20	BOLT 5X20	
1-17	028050242	1	ハ"ネサ"カ"ネ2-5	SPRING WASHER 2-5	
1-18	S08443001	1	スライト"カ"イト"	SLIDE GUIDE	
1-19	073050002	1	シ"クウケナツトAN05	BEARING NUT AN05	
1-20	S08444000	2	ト"ライヘ"アリンク"	DRY BEARING	
1-21	S08445001	1	トリツクイタ	SETTING PLATE	
1-22	S08446000	1	シリンタ"クミ	CYLINDER ASSEMBLY	
1-22-1	S08447000	1	シリンタ"20X50	CYLINDER 20X50	
1-22-2	S04910000	2	ハ-フユニオン	HALF UNION	
1-23	S08448001	1	ナツト	NUT	
1-24	018501622	2	アナホ"ルト5X16	BOLT 5X16	
1-25	028050242	2	ハ"ネサ"カ"ネ2-5	SPRING WASHER 2-5	
1-26	025050232	2	ヒラサ"カ"ネチユウ-5	PLAIN WASHER 5	
1-27	S08450001	1	スタッカ-ト"ク"イ	STACKER BRACKET	
1-28	018082022	4	アナホ"ルト8X20	BOLT 8X20	
1-29	028080242	4	ハ"ネサ"カ"ネ2-8	SPRING WASHER 2-8	
1-30	025080232	4	ヒラサ"カ"ネチユウ8	PLAIN WASHER 8	
1-31	149342001	2	ヒ"ロフ"ロツク	PILLOW BLOCK	
1-32	018081222	4	アナホ"ルト8X12	BOLT 8X12	
1-33	028080242	4	ハ"ネサ"カ"ネ2-8	SPRING WASHER 2-8	
1-34	025080232	4	ヒラサ"カ"ネチユウ8	PLAIN WASHER 8	
1-35	S08514001	1	スタッカ-シデンシ"ク	STACKER FULCRUM SHAFT	
1-36	014060622	2	アナトメネシ"6X6クホ"ミ	SET SCREW 6X6	
1-37	S08449001	1	スタッカ-ア-ム	STACKER ARM	
1-38	S09406000	1	シリンタ"クミ	CYLINDER ASSEMBLY	
1-38-1	S09407000	1	シリンタ"25X150	CYLINDER 25X150	
1-38-2	S04910000	2	ハ-フユニオン	HALF UNION	
1-39	149487001	1	リンクホ-ール	LINK BALL	
1-40	149488001	1	ロツト"ナツト	ROD NUT	
1-41	025100232	1	ヒラサ"カ"ネチユウ10	PLAIN WASHER 10	
1-42	028100243	2	ハ"ネサ"カ"ネ2-10	SPRING WASHER 2-10	
1-43	S09618001	1	シリンタ"トリツクカナク"	CYLINDER FITTING CLAMP	
1-44	S09619001	1	シリンタ"トリツクピン	PIN	
1-45	048050342	2	トメワE5	STOP RING E5	
1-46	018501622	2	アナホ"ルト5X16	BOLT 5X16	
1-47	028050242	2	ハ"ネサ"カ"ネ2-5	SPRING WASHER 2-5	
1-48	S15061001	1	キシ"ク"イア-ム	CLOTH STACKER ARM	
1-49	018082022	2	アナホ"ルト8X20	BOLT 8X20	
1-50	028080242	2	ハ"ネサ"カ"ネ2-8	SPRING WASHER 2-8	
1-51	025080232	2	ヒラサ"カ"ネチユウ8	PLAIN WASHER 8	
1-52	S08398001	1	スタッカ-テ-ブルクミ	STACKER TABLE ASSEMBLY	
1-52-1	S08458001	1	スタッカ-テ-ブル	STACKER TABLE	
1-52-2	S08459000	2	スタッカ-テ-ブルゴム	STACKER TABLE RUBBER	
1-53	062400816	6	ナヘ"コ4X8	SCREW 4X8	

L. スタッカー関係/Stacker mechanism/Anhufung/  
Mecanisme de l'empileur/Mecanismo de apilador

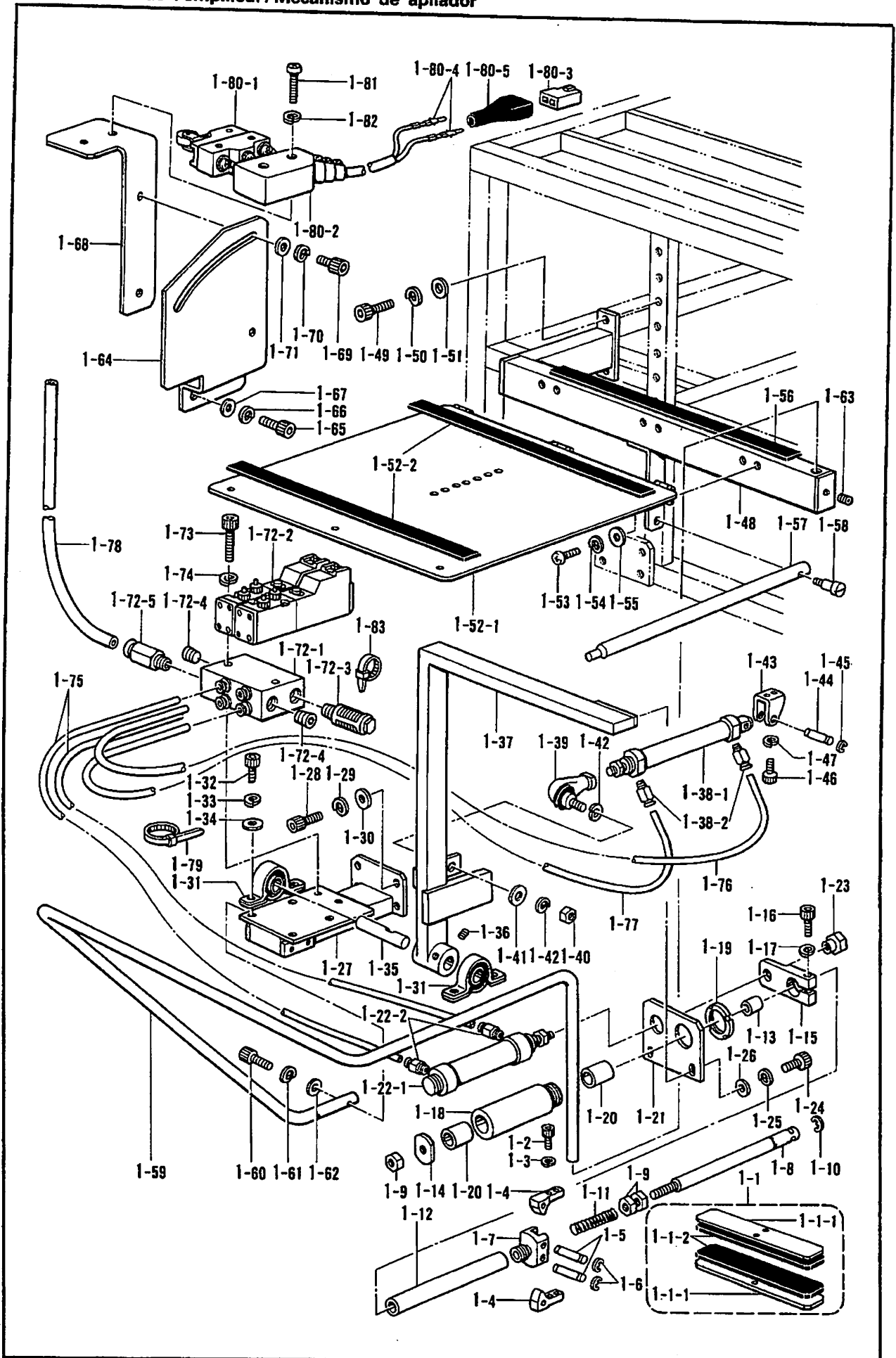

L. スタッカー関係/Stacker mechanism/Anhäufung/  
Mécanisme de l'empileur/Mecanismo de apilador

REF.NO.	CODE	Q'TY	ヒンメイ	NAME OF PARTS	RMKS
1-54	028040243	6	ハ"ネサ"カ"ネ2-4	SPRING WASHER 2-4	
1-55	025040233	6	ヒラサ"カ"ネチユウ4	PLAIN WASHER 4	
1-56	S08459000	1	スタッカーテーブルゴム	STACKER TABLE RUBBER	
1-57	S08460001	1	テーブルササエホ"ウ	TABLE SPOTER BAR	
1-58	147933001	1	ダンネシ"5.95	STUD SCREW 5.95	
1-59	S15062001	1	ガード"バー	GUARD BAR	
1-60	018062522	2	アナボ"ルト6X25	BOLT 6X25	
1-61	028060242	2	ハ"ネサ"カ"ネ 2-6	SPRING WASHER 2-6	
1-62	025060232	2	ヒラサ"カ"ネチユウ 6	PLAIN WASHER 6	
1-63	014500522	1	アナトメネシ"5クホ"ミ	SET SCREW 5	
1-64	S08470001	1	スタッカースイッチダ"イ	STACKER SWITCH BASE	
1-65	018061622	2	アナボ"ルト6X16	BOLT 6X16	
1-66	028060242	2	ハ"ネサ"カ"ネ 2-6	SPRING WASHER 2-6	
1-67	025060232	2	ヒラサ"カ"ネチユウ 6	PLAIN WASHER 6	
1-68	S08471001	1	スタッカースイッチレ"バー	STACKER SWITCH LEVER	
1-69	018501022	2	アナボ"ルト5X10	BOLT 5X10	
1-70	028050242	2	ハ"ネサ"カ"ネ2-5	SPRING WASHER 2-5	
1-71	025050232	2	ヒラサ"カ"ネチユウ-5	PLAIN WASHER 5	
1-72	S08135001	1	ハ"ルブ"ユニットSTK	VALVE UNIT	
1-72-1	S08151000	1	マニボ"ルト"S-2	MANIFOLD S-2	
1-72-2	S08154000	2	ハ"ルブ"VZ3150	VALVE VZ3150	
1-72-3	140682001	1	サイレンサー	SILENCER	
1-72-4	153274001	2	1/8トメセン	CAP 1/8	
1-72-5	S08152000	1	ハーフユニオン1/8-8	HALF UNION 1/8-8	
1-73	018503022	2	アナボ"ルト5X30	BOLT 5X30	
1-74	028050242	2	ハ"ネサ"カ"ネ2-5	SPRING WASHER 2-5	
1-75	S08138000	2	エア"ホースS-A	AIR TUBE S-A	
1-76	S08139000	1	エア"ホースS-B	AIR TUBE S-B	
1-77	S08140000	1	エア"ホースS-C	AIR TUBE S-C	
1-78	S08361000	1	エア"ホース8-B	AIR TUBE 8-B	
1-79	S04557000	5	ハ"ンタイPLTIM	BAND PLTIM	
1-80	S08127001	1	リミットスイッチク"ミ	LIMIT SWITCH ASSEMBLY	
1-80-1	S08131000	1	リミットスイッチ	LIMIT SWITCH	
1-80-2	147926000	1	マイクロスイッチカ"バー	MICRO SWITCH COVER	
1-80-3	S08007000	1	コネクタ5025-02P1	CONNECTOR 5025-02P1	
1-80-4	S08017000	2	オスピン5006TL	MALE PIN 5006TL	
1-80-5	143489001	1	コネクタキャツ"プ	CONNECTOR CAP	
1-81	002402502	2	プラスナ"ヘ"ネシ"4X25	SCREW 4X25	
1-82	028040242	2	ハ"ネサ"カ"ネチユウ4	SPRING WASHER 2-4	
1-83	149809000	3	タイラツ"プL	BEAD BAND (LARGE)	

L. スタッカー関係/Stacker mechanism/Anhufung/  
Mecanisme de l'empilleur/Mecanismo de apilador

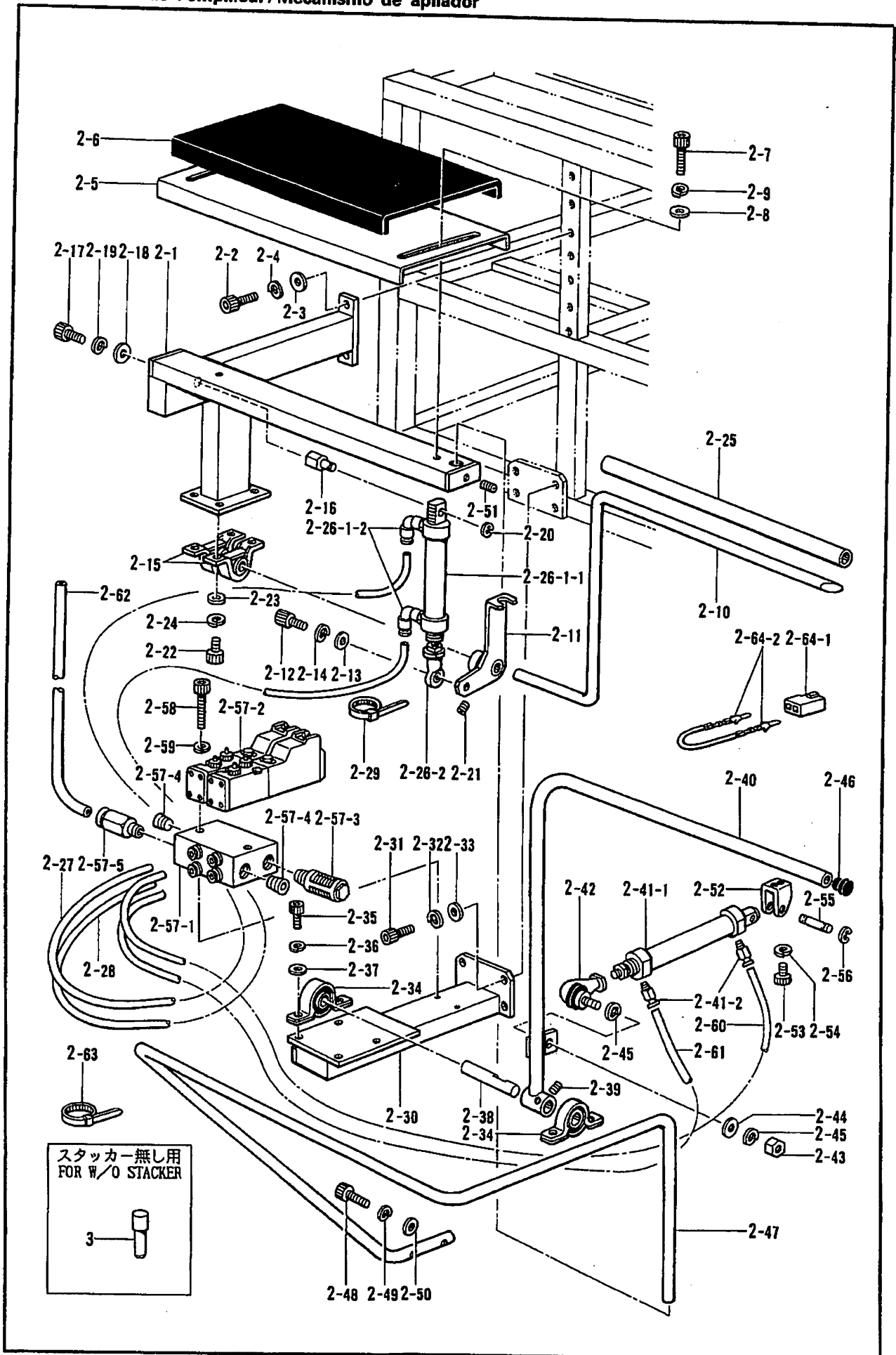

L. スタッカー関係/Stacker mechanism/Anhäufung/  
Mécanisme de l'empileur/Mecanismo de apilador

REF.NO.	CODE	Q'TY	ヒンメイ	NAME OF PARTS	RMKS
2	S08124101	1	バースタッカクミ	BAR STACKER ASSEMBLY	
2-1	S15063001	1	バースタッカーキジタイプ	BAR TYPE STACKER CLOTH BASE	
2-2	018082022	2	アナボルト8X20	BOLT 8X20	
2-3	025080232	2	ヒラサカネチユウ8	PLAIN WASHER 8	
2-4	028080242	2	ハネサカネ2-8	SPRING WASHER 2-8	
2-5	S06736001	1	スタッカーウケイタ	STACKER PLATE	
2-6	S06737000	1	スタッカスポンジL	PACKING (LARGE)	
2-7	018505022	2	アナボルト5X50	BOLT 5X50	
2-8	025050232	2	ヒラサカネチユウ5	PLAIN WASHER 5	
2-9	028050242	2	ハネサカネ2-5	SPRING WASHER 2-5	
2-10	S15064001	1	スタッカーバーL	STACKER BAR (LARGE)	
2-11	S06739001	1	スタッカーウテL	STACKER ARM (LARGE)	
2-12	018082522	1	アナボルト8X25	BOLT 8X25	
2-13	025080232	1	ヒラサカネチユウ8	PLAIN WASHER 8	
2-14	028080242	1	ハネサカネ2-8	SPRING WASHER 2-8	
2-15	S06740001	2	ヘアリンクASPP202	BEARING ASPP202	
2-16	S06741001	1	シリンダトメカナク	CYLINDER STUD	
2-17	018081222	1	アナボルト8X12	BOLT 8X12	
2-18	025080232	1	ヒラサカネチユウ8	PLAIN WASHER 8	
2-19	028080242	1	ハネサカネ2-8	SPRING WASHER 2-8	
2-20	048060342	1	トメワE6	STOP RING E6	
2-21	014500522	2	アナトメネシ5クホミ	SET SCREW 5	
2-22	151163001	4	アナボルト8X15	BOLT 8X15	
2-23	025080232	4	ヒラサカネチユウ8	PLAIN WASHER 8	
2-24	028080242	4	ハネサカネ2-8	SPRING WASHER 2-8	
2-25	S06744000	1	チューブL	AIR TUBE (LARGE)	
2-26-1	S11685000	1	シリンダクミ	CYLINDER ASSEMBLY	
2-26-1-1	S06897000	1	シリンダ20X75	CYLINDER 20X75	
2-26-1-2	S06886000	2	ツキテ1/8-4	JOINT 1/8-4	
2-26-2	S08352000	1	ロッドエンド	ROD END	
2-27	S08125000	1	エアホース4-S1	AIR TUBE 4-S1	
2-28	S08126000	1	エアホース4-S2	AIR TUBE 4-S2	
2-29	S04557000	2	ハンタイPLTIM	BAND PLTIM	
2-30	S15065001	1	スタッカーカートタイプ	STACKER BRACKET	
2-31	018082022	4	アナボルト8X20	BOLT 8X20	
2-32	028080242	4	ハネサカネ2-8	SPRING WASHER 2-8	
2-33	025080232	4	ヒラサカネチユウ8	PLAIN WASHER 8	
2-34	149342001	2	ヒロフブロック	PILLOW BLOCK	
2-35	018081222	4	アナボルト8X12	BOLT 8X12	
2-36	028080242	4	ハネサカネ2-8	SPRING WASHER 2-8	
2-37	025080232	4	ヒラサカネチユウ8	PLAIN WASHER 8	
2-38	S08514001	1	スタッカーシテンシク	STACKER FULCRUM SHAFT	
2-39	014060622	2	アナトメネシ6X6クホミ	SET SCREW 6X6	
2-40	S15066001	1	スタッカーバー	STACKER BAR	
2-41	S09406000	1	シリンダクミ	CYLINDER ASSEMBLY	
2-41-1	S09407000	1	シリンダ25X150	CYLINDER 25X150	
2-41-2	S04910000	2	ーフユニオン	HALF UNION	
2-42	149487001	1	リンクボール	LINK BALL	
2-43	149488001	1	ロッドナット	ROD NUT	
2-44	025100232	1	ヒラサカネチユウ10	PLAIN WASHER 10	
2-45	028100242	2	ハネサカネ2-10	SPRING WASHER 2-10	
2-46	117934001	1	メクラセン	OIL CAP	
2-47	S15062001	1	ガードバー	GUARD BAR	
2-48	018062522	2	アナボルト6X25	BOLT 6X25	
2-49	028060242	2	ハネサカネ2-6	SPRING WASHER 2-6	
2-50	025060232	2	ヒラサカネチユウ6	PLAIN WASHER 6	
2-51	014500522	1	アナトメネシ5クホミ	SET SCREW 5	
2-52	S09618001	1	シリンダトリツケカナク	CYLINDER FITTING CLAMP	
2-53	018501622	2	アナボルト5X16	BOLT 5X16	
2-54	028050242	2	ハネサカネ2-5	SPRING WASHER 2-5	
2-55	S09619001	1	シリンダトリツケピン	PIN	
2-56	048050342	2	トメワE5	STOP RING E5	

L. スタッカー関係/Stacker mechanism/Anhufung/  
Mecanisme de l'empileur/Mecanismo de apilador

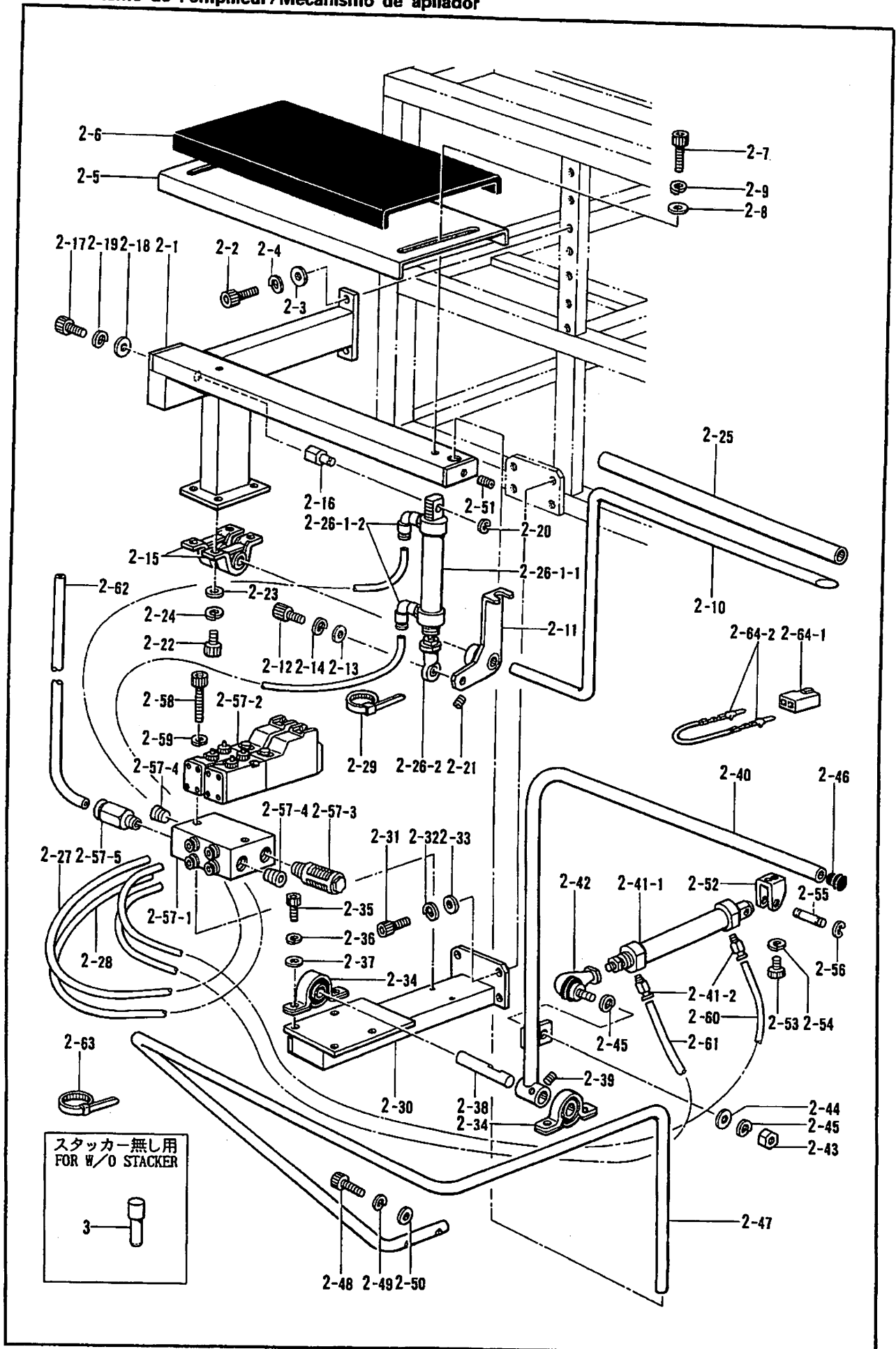

L. スタッカー関係/Stacker mechanism/Anhäufung/  
 Mécanisme de l'empileur/Mecanismo de apilador

REF.NO.	CODE	Q'TY	品名	NAME OF PARTS	RMKS
2-57	S08135001	1	バルブユニットSTK	VALVE UNIT	
2-57-1	S08151000	1	マニホルトS-2	MANIFOLD S-2	
2-57-2	S08154000	2	バルブVZ3150	VALVE VZ3150	
2-57-3	140682001	1	サイレンサー	SILENCER	
2-57-4	153274001	2	1/8トメセン	CAP 1/8	
2-57-5	S08152000	1	ハーフユニオン1/8-8	HALF UNION 1/8-8	
2-58	018503022	2	アナボルト5X30	BOLT 5X30	
2-59	028050242	2	ハネサガネ2-5	SPRING WASHER 2-5	
2-60	S08139000	1	エアホースS-B	AIR TUBE S-B	
2-61	S08140000	1	エアホースS-C	AIR TUBE S-C	
2-62	S08361000	1	エアホース8-B	AIR TUBE 8-B	
2-63	S04557000	4	バンドPLTIM	BAND PLTIM	
2-64	S08130000	1	コネクタ2Pクミ	CONNECTOR (2P) ASSEMBLY	
2-64-1	S08007000	1	コネクタ5025-02P1	CONNECTOR 5025-02P1	
2-64-2	S08017000	2	オスピン5006TL	MALE PIN 5006TL	
3	S08134000	1	トメセン8	CAP 8	



M. 糸巻関係 / Bobbin winder mechanism / Spuler /  
 Mécanisme du bobineur / Mecanismo del devanador de la canilla

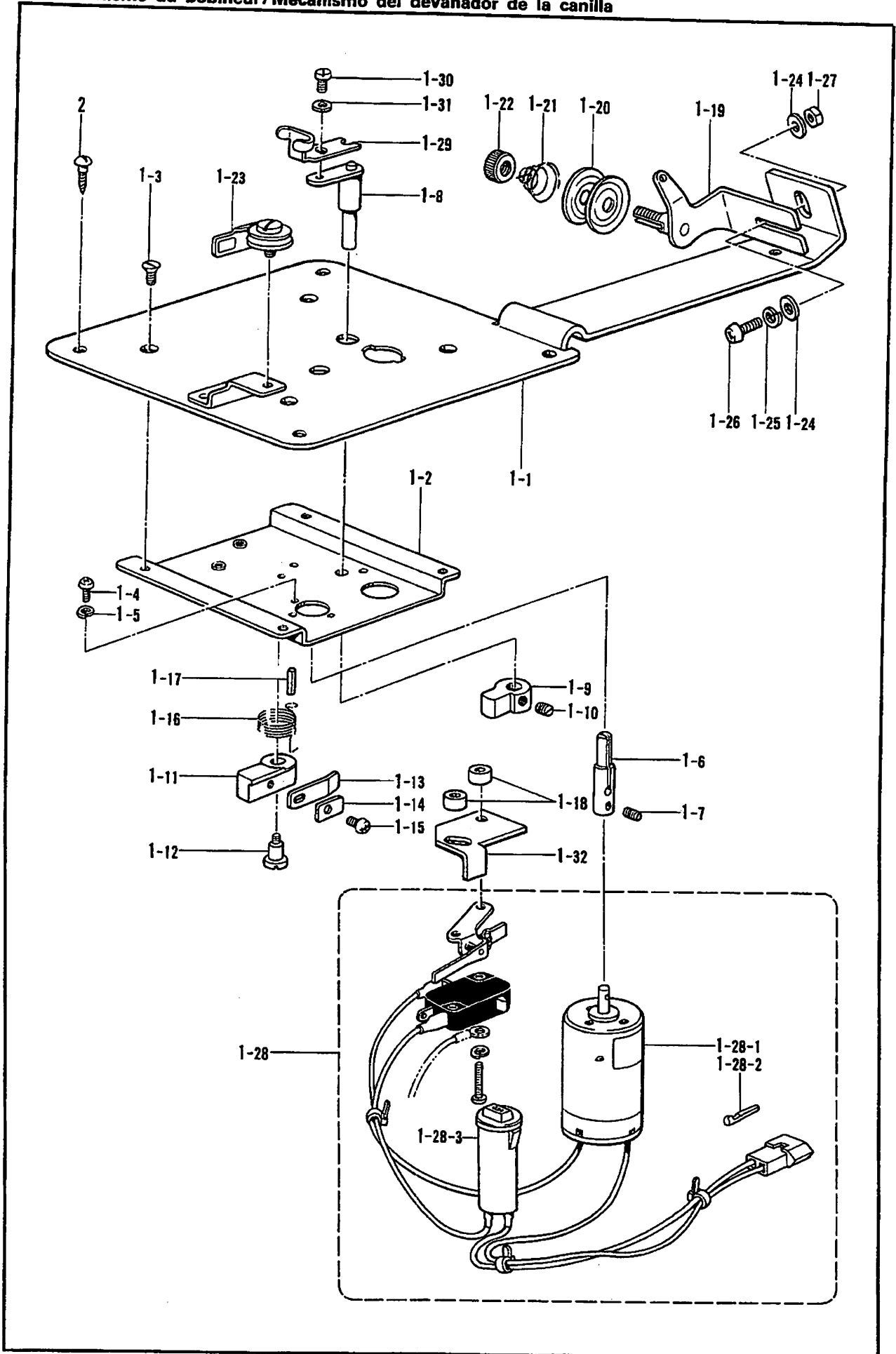

M. 糸巻関係/Bobbin winder mechanism/Spuler/  
Mécánisme du bobineur/Mecanismo del devanador de la canilla

REF.NO.	CODE	QTY	ヒンメイ	NAME OF PARTS	RMKS
1	152651301	1	イトマキソウチクミ	BOBBIN WINDER ASSEMBLY	
1-1	152356301	1	イトマキト"タ"イ	BOBBIN WINDER BASE	
1-2	152357101	1	イトマキモホータシシ"イタ	BOBBIN WINDER MOTOR INDICATE PLATE	
1-3	004300513	4	+サラネシ"3X5	SCREW 3X5	
1-4	062300605	3	ナヘ"コ3X6	SCREW 3X6	
1-5	028030242	3	ハ"ネサ"カ"ネ2-3	SPRING WASHER 2-3	
1-6	152358001	1	イトマキシ"ク	BOBBIN WINDER SHAFT	
1-7	014300332	2	アナクホ"ミ3X3	SCREW 3X3	
1-8	154024001	1	ホ"ヒ"ンオサエ	BOBBIN HOLDER ARM	
1-9	154092001	1	イトマキツメタ"ンツキ	BOBBIN WINDER CLAW	
1-10	014680422	2	アナトメネシ"4.37クホ"ミ	SET SCREW 4.37	
1-11	152361001	1	イトアキレハ"ー	BOBBIN WINDER LEVER	
1-12	152362001	1	イトマキタ"ンネジ"	BOBBIN WINDER STUD SCREW	
1-13	111942001	1	イタハ"ネ	PLATE SPRING	
1-14	111943001	1	イタハ"ネサ"カ"ネ	PLATE SPRING WASHER	
1-15	060660512	1	ハ"イント"318-40X5	SCREW 3.18X5	
1-16	152363001	1	ネシ"リハ"ネA	TWIST SPRING (A)	
1-17	047301042	1	スプリング"ピン	SPRING PIN	
1-18	152364001	2	カラー	COLLAR	
1-19	145571101	1	イトマキアンナイダ"イクミ	BOBBIN WINDER GUIDE BRACKET ASSEMBLY	
1-20	145446001	2	イトチヨウシサラ	TENSION DISC	
1-21	100401001	1	イトチヨウシハ"ネ	TENSION SPRING	
1-22	100136001	1	イトチヨウシナット	TENSION NUT	
1-23	146197001	1	イトツカミクミ	THREAD CLAMP ASSEMBLY	
1-24	025040233	2	ヒラサ"カ"ネチユウ4	PLAIN WASHER 4	
1-25	028040243	1	ハ"ネサ"カ"ネ2-4	SPRING WASHER 2-4	
1-26	062401006	1	ナヘ"コ4X10	SCREW 4X10	
1-27	021400103	1	ナット1シユ4	NUT 4	
1-28	S16699000	1	イトマキモータクミ	BOBBIN WINDER MOTOR ASSEMBLY	
1-28-1	S16667000	1	イトマキモータ	BOBBIN WINDER MOTOR	
1-28-2	552851001	2	ピンターミナル#1854	TERMINAL PIN #1854	
1-28-3	S16700000	1	プロテクタ0.3A	PROTECT 0.3A	
1-29	152645001	1	ホ"ヒ"ンオサエイタ	BOBBIN PRESSER PLATE	
1-30	007300613	1	ヒラネシ"3X6	SCREW 3X6	
1-31	025030233	1	ヒラサ"カ"ネチユウ3	PLAIN WASHER 3	
1-32	158597001	1	イトマキストツハ"ー	BOBBIN WINDER STOPPER	
2	032311306	5	+マルモクネシ"3.1X13	SCREW 3.1X13	

N. 糸切り関係/Thread trimmer mechanism/Fadenabschneidevorrichtung/  
 Mécanisme de coupe fil/Mecanismo de recortadora de orillos

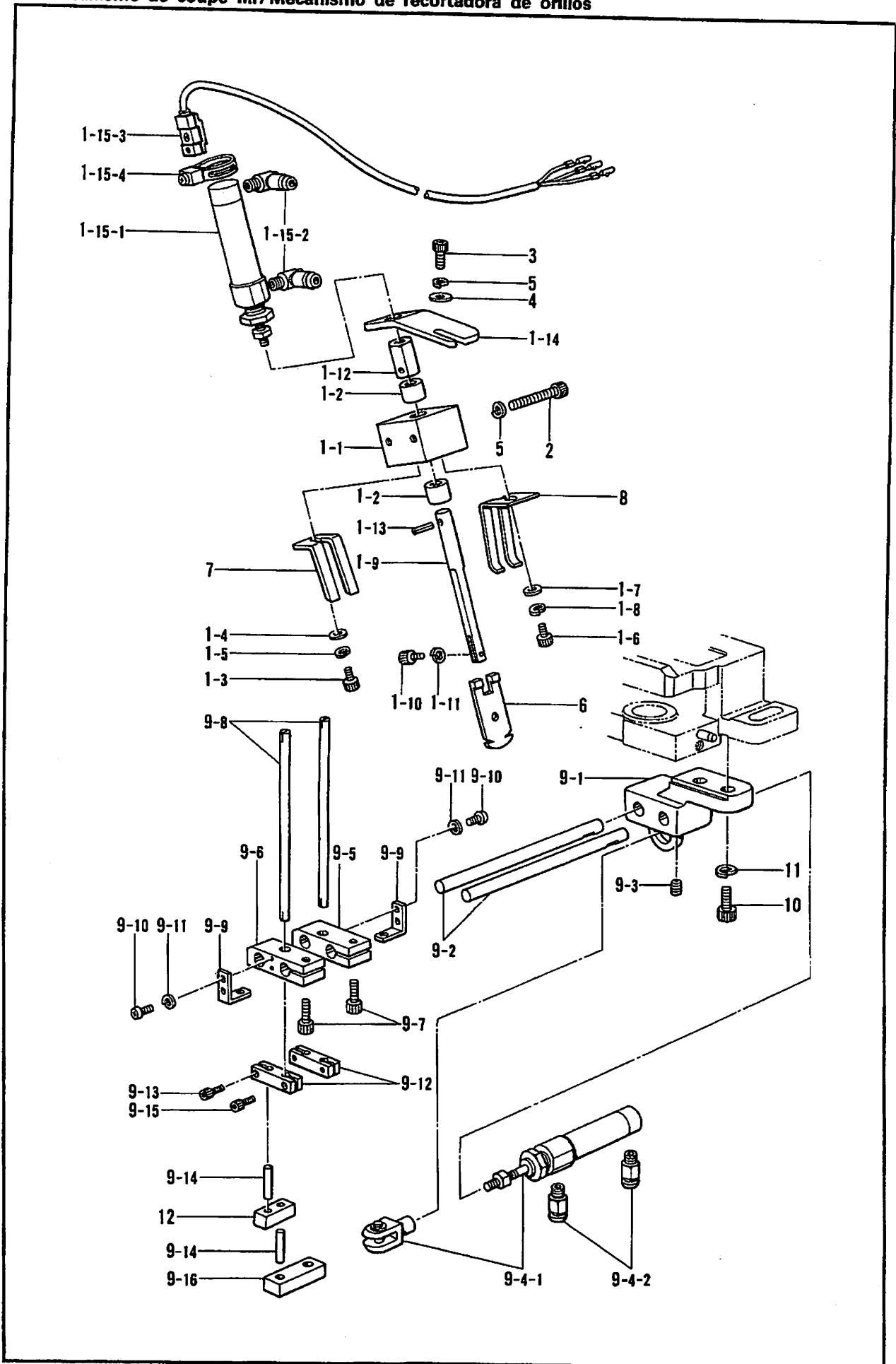

N. 糸切り関係/Thread trimmer mechanism/Fadenabschneidevorrichtung/  
Mécánisme de coupe fill/Mecanismo de recortadora de orillos

REF.NO.	CODE	Q'TY	ヒンメイ	NAME OF PARTS	RMKS
1	S16146001	1	ウフイメスクミ	NEEDLE THREAD KNIFE ASSEMBLY	
1-1	S14689001	1	メスホ"ウカ"イト"	KNIFE BAR GUIDE	
1-2	S08397000	2	ト"ライハ"アリンク"	DRY BEARING	
1-3	018300822	1	アナホ"ルト3X8	BOLT 3X8	
1-4	025030132	1	ヒラサ"カ"ネシヨウ3	PLAIN WASHER 3	
1-5	028030242	1	ハ"ネサ"カ"ネ2-3	SPRING WASHER 2-3	
1-6	018300822	1	アナホ"ルト3X8	BOLT 3X8	
1-7	025030132	1	ヒラサ"カ"ネシヨウ3	PLAIN WASHER 3	
1-8	028030242	1	ハ"ネサ"カ"ネ2-3	SPRING WASHER 2-3	
1-9	S14802001	1	メスホ"ウ	KNIFE BAR	
1-10	018300822	1	アナホ"ルト3X8	BOLT 3X8	
1-11	028030242	1	ハ"ネサ"カ"ネ2-3	SPRING WASHER 2-3	
1-12	S14690001	1	ツキ"テ	JOINT	
1-13	047301242	1	スフ"リンク"ヒンAW3	SPRING PIN AW3	
1-14	S14691001	1	シリンダ"タイ	CYLINDER BRACKET	
1-15	S08406000	1	シリンダ"クミ	CYLINDER ASSEMBLY	
1-15-1	S08407000	1	シリンダ"16X30	CYLINDER 16X30	
1-15-2	S06883000	2	Sエルボ"M5-4	S-ELBOW M5-4	
1-15-3	S08488000	1	シリンダ"-センサ	CYLINDER SENSOR	
1-15-4	S08500000	1	トリツクカナク"16	FITTING CLAMP 16	
2	018403022	2	アナホ"ルト4X30	BOLT 4X30	
3	018401022	2	アナホ"ルト4X10	BOLT 4X10	
4	025040232	2	ヒラサ"カ"ネチユウ4	PLAIN WASHER 4	
5	028040242	4	ハ"ネサ"カ"ネ2-4	SPRING WASHER 2-4	
6	*	1	ウフイメス	MOVABLE KNIFE	
7	*	1	コテイハ	FIXED KNIFE	
8	*	1	イトホシ"ハ"ネ	THREAD RETAINER SPRING	
9	S16147001	1	シタイトメスクミ	LOWER THREAD KNIFE ASSEMBLY	
9-1	S14692001	1	メスト"タイ	KNIFE BASE	
9-2	S08377001	2	カ"イト"シ"ク	GUIDE SHAFT	
9-3	014400422	2	アナトメネシ"4X4クホ"ミ	SET SCREW 4X4	
9-4	S08387000	1	シリンダ"クミ	CYLINDER ASSEMBLY	
9-4-1	S08388000	1	シリンダ"16X15	CYLINDER 16X15	
9-4-2	S06882000	2	ツキ"テM5-4	JOINT M5-4	
9-5	S14693001	1	メスホルダ"R	KNIFE HOLDER (RIGHT)	
9-6	S14694001	1	メスホルダ"L	KNIFE HOLDER (LEFT)	
9-7	018401222	2	アナホ"ルト4X12	BOLT 4X12	
9-8	S08381001	2	メス	KNIFE	
9-9	S08382001	2	ストツパ	STOPPER	
9-10	062300616	4	ナハ"コM3X6	SCREW M3X6	
9-11	028030243	4	ハ"ネサ"カ"ネ2-3	SPRING WASHER 2-3	
9-12	S08383001	2	リンクA	LINK (A)	
9-13	018300622	2	アナホ"ルト3X6	BOLT 3X6	
9-14	S08384001	2	シ"ク4X19.8	SHAFT 4X19.8	
9-15	018300622	2	アナホ"ルト3X6	BOLT 3X6	
9-16	S08386001	1	リンクC	LINK (C)	
10	018501622	2	アナホ"ルト5X16	BOLT 5X16	
11	028050242	2	ハ"ネサ"カ"ネ2-5	SPRING WASHER 2-5	
12	*	1	リンクB	LINK (B)	

P. 針位置検出器関係 / Synchronizer / Synchronisator /  
Synchronisateur / Sincronizador

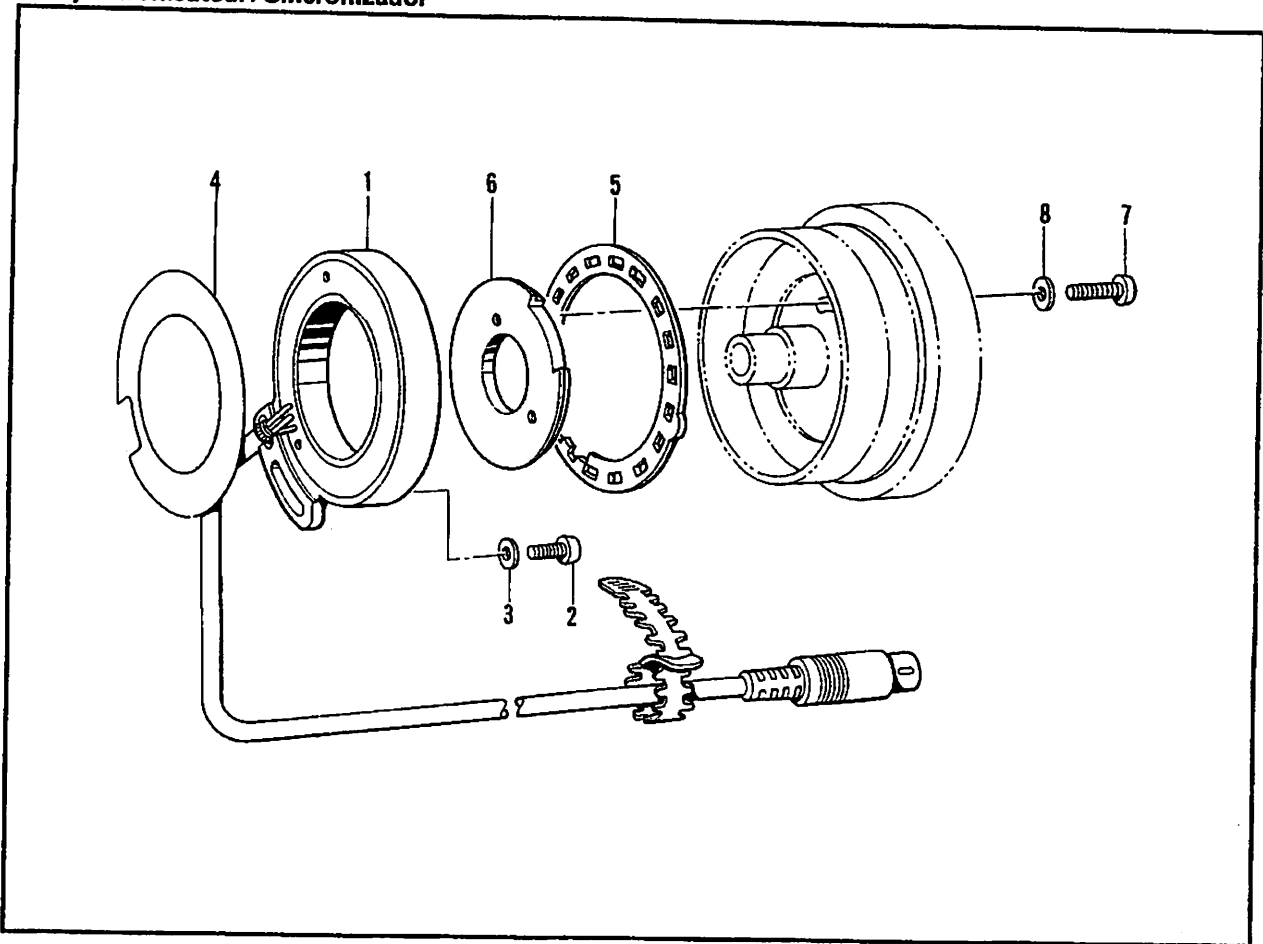

Q. コントロールボックス関係 / Control box mechanism / Schaltkasten /  
Mécanisme du boîtier de contrôle / Mecanismo de la caja de controles

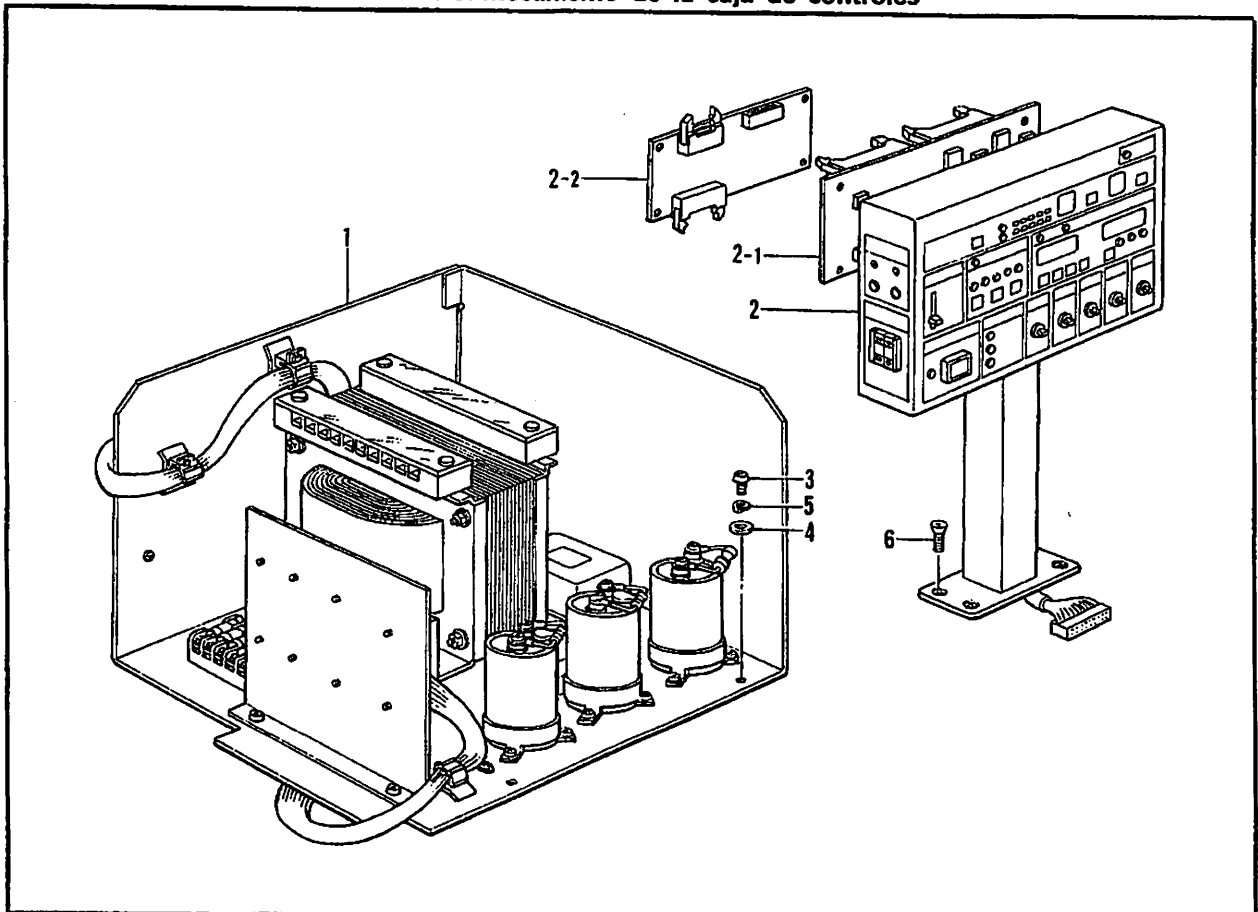

P. 針位置検出器関係/Synchronizer/Synchronisator/  
Synchronisateur/Sincronizador

REF.NO.	CODE	Q'TY	ヒンメイ	NAME OF PARTS	RMKS
1	230157001	1	シンクロナイザクミ#14-2	SYNCHRONIZER ASSEMBLY #14-2	
2	062711012	1	ナヘコ476-32X10	SCREW 476X10	
3	113431002	1	サカガネ	WASHER	
4	S06241000	1	セツエンシート	INSULATION SEAT	
5	S06242001	1	ソクトシレイタ	SPEED COMMAND PLATE	
6	S14675001	1	ハリウエイタ	NEEDLE UPPER PLATE	
7	062681612	2	ナヘコ437-40X16	SCREW 437X16	
8	100645003	2	サカガネ	WASHER	

Q. コントロールボックス関係/Control box mechanism/Schaltkasten/  
Mécanisme du boîtier de contrôle/Mecanismo de la caja de controles

REF.NO.	CODE	Q'TY	ヒンメイ	NAME OF PARTS	RMKS
1	S08021101	1	デングンユニットクミ	POWER UNIT ASSEMBLY	
2	S14402001	1	ソウサホツクスクミ	-----	
2	S14402002	1	-----	OPERATION BOX ASSEMBLY	
2-1	S14406000	1	キハ"ンB439047クミ	CIRCUIT BOARD (B439047) ASSEMBLY	
2-2	S08093000	1	キハ"ンB439012クミ	CIRCUIT BOARD (B439012) ASSEMBLY	
3	062400806	5	ナヘコ4X8	SCREW 4X8	
4	025040233	5	ヒラサカネチユウ4	PLAIN WASHER 4	
5	028040243	5	ハ"ネサカ"ネ2-4	SPRING WASHER 2-4	
6	149320001	4	アナツキサラボルトM6X40	BOLT M6X40	

R. 空圧関係 / Air pressure mechanism / Luftdruck /  
 Mécanisme de la pression d'air / Mecanismo de la presión de aire

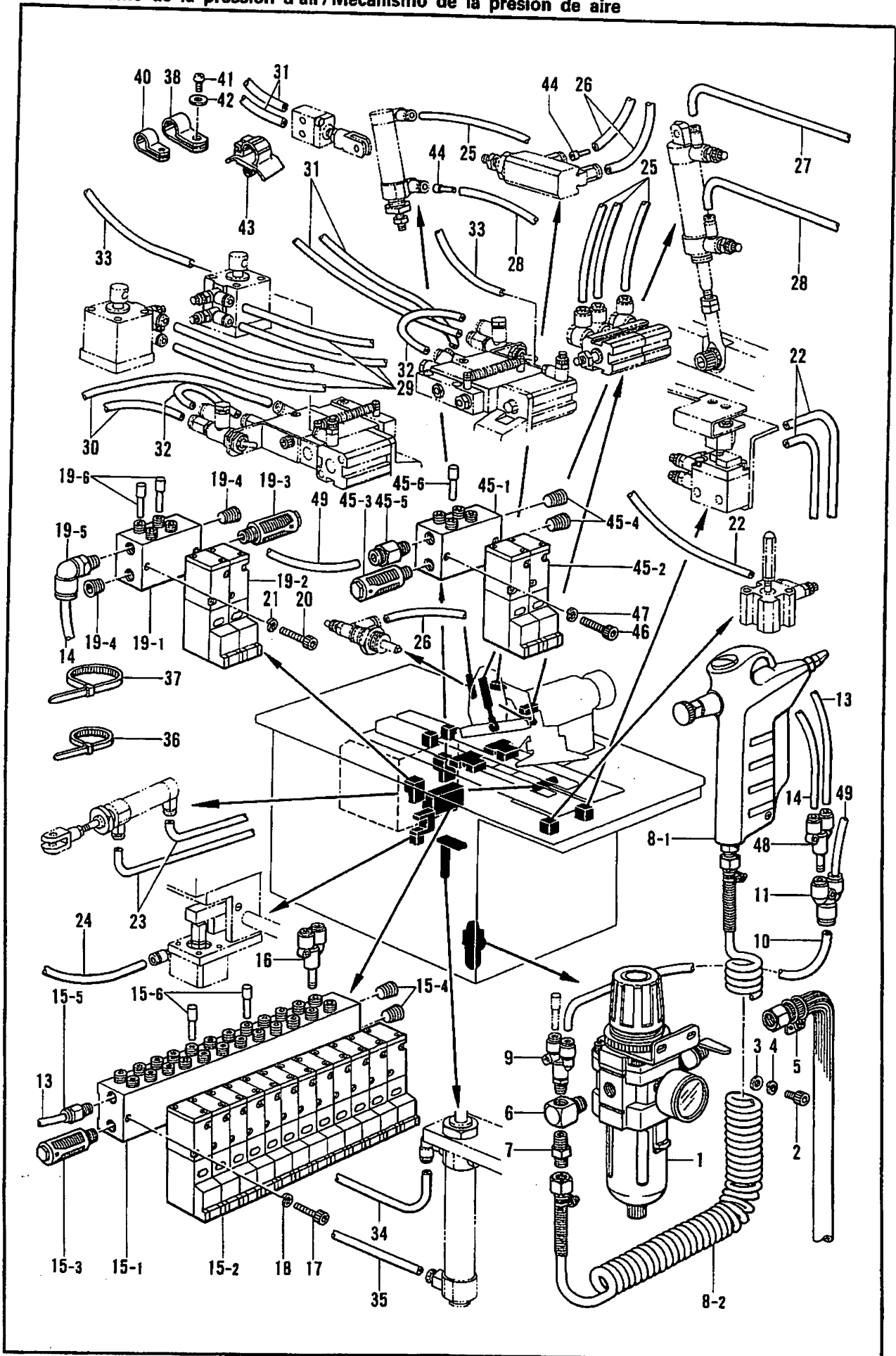

R. 空圧関係/Air pressure mechanism/Luftdruck/  
Mécanisme de la pression d'air/Mecanismo de la presión de aire

REF.NO.	CODE	QTY	ヒンメイ	NAME OF PARTS	RMKS
1	S16162000	1	エアユニット	AIR UNIT	
2	018061222	2	アナホルト6X12	BOLT 6X12	
3	025060232	2	ヒラサガネチユウ 6	PLAIN WASHER 6	
4	028060242	2	ハネサガネ 2-6	SPRING WASHER 2-6	
5	149796001	1	ゴムホースカナクツキ	AIR TUBE WITH CONNECTOR	
6	153252000	1	PTチース	PT-JOINT	
7	S04891000	1	チユウカンニツプル1/4	MIDDLE NIPPLE 1/4	
8	S06857000	1	エアガンクミ	AIR GAN ASSEMBLY	
8-1	S06858000	1	エアガン	AIR GAN	
8-2	S06859000	1	カールホース	CURL TUBE	
9	S08143000	1	ブランチY1/4-8	BRANCH Y 1/4-8	
10	S08144000	1	エアホース8-A	AIR TUBE 8-A	
11	S08145000	1	ユニオンY8-6	UNION Y-8-6	
13	S08146000	1	エアホース6-A	AIR TUBE 6-A	
14	S08147000	1	エアホース6-B	AIR TUBE 6-B	
15	S15076101	1	ハルプユニット	VALVE UNIT	
15-1	S15077000	1	マニホルトS-12	MANIFOLD S-12	
15-2	S08155000	12	ハルプVZ3140	VALVE VZ3140	
15-3	140682001	1	サイレンサー	SILENCER	
15-4	153274001	2	1/8トメセン	CAP 1/8	
15-5	S01522000	1	ハーフユニオン	HALF UNION	
15-6	S04897000	2	メクラセン	BLIND CAP	
16	S08178000	3	ブランチUY-4	BRANCH UY-4	
17	018503022	2	アナホルト5X30	BOLT 5X30	
18	028050242	2	ハネサガネ2-5	SPRING WASHER 2-5	
19	S08159001	1	ハルプユニットFLP	VALVE UNIT (FOR FLAP)	
19-1	S08151000	1	マニホルトS-2	MANIFOLD S-2	
19-2	S08155000	2	ハルプVZ3140	VALVE VZ3140	
19-3	140682001	1	サイレンサー	SILENCER	
19-4	153274001	2	1/8トメセン	CAP 1/8	
19-5	S01542000	1	エルボユニオン61	ELBOW UNION 61	
19-6	S04897000	2	メクラセン	BLIND CAP	
20	018503022	2	アナホルト5X30	BOLT 5X30	
21	028050242	2	ハネサガネ2-5	SPRING WASHER 2-5	
22	S08163000	3	エアホース4-B	AIR TUBE 4-B	
23	S08164000	2	エアホース4-C	AIR TUBE 4-C	
24	S08165000	1	エアホース4-D	AIR TUBE 4-D	
25	S08166000	4	エアホース4-E	AIR TUBE 4-E	
26	S08167000	3	エアホース4-F	AIR TUBE 4-F	
27	S08168000	1	エアホース4-G	AIR TUBE 4-G	
28	S08169000	2	エアホース4-H	AIR TUBE 4-H	
29	S08171000	4	エアホース4-J	AIR TUBE 4-J	
30	S08172000	2	エアホース4-K	AIR TUBE 4-K	
31	S08173000	4	エアホース4-L	AIR TUBE 4-L	
32	S08174000	2	エアホース4-M	AIR TUBE 4-M	
33	S08175000	2	エアホース4-N	AIR TUBE 4-N	
34	S08176000	1	エアホース4-O	AIR TUBE 4-O	
35	S08177000	1	エアホース4-P	AIR TUBE 4-P	
36	S04557000	17	ハンタイPLTIM	BAND PLTIM	
37	149809000	2	タイラツプル	BEAD BAND (LARGE)	
38	554482000	2	コードホルダ#12	CORD HOLDER #12	
40	552907000	1	コードホルダ#10	CORD HOLDER #10	
41	062401006	3	ナハコ4X10	SCREW 4X10	
42	025040233	3	ヒラサガネチユウ4	PLAIN WASHER 4	
43	S09141000	1	コードクランプ#16L	CORD CLAMP (16L)	
44	S10657000	2	シホリノズル	THROTTLE NOZZLE	



R. 空圧関係 / Air pressure mechanism / Luftdruck /  
Mécanisme de la pression d'air / Mecanismo de la presión de aire

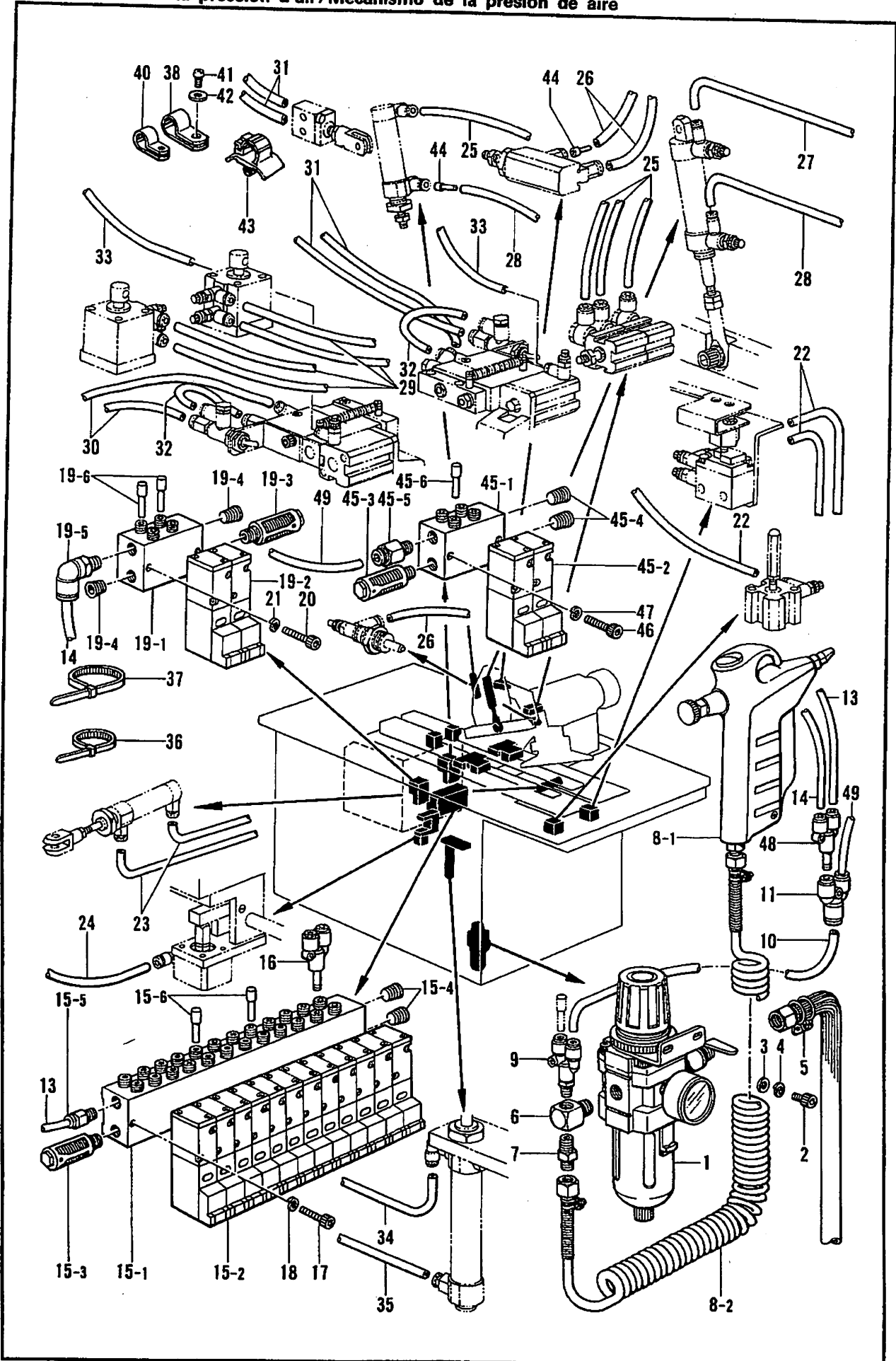

R. 空圧関係/Air pressure mechanism/Luftdruck/  
 Mécanisme de la pression d'air/Mecanismo de la presión de aire

REF.NO.	CODE	Q'TY	品名	NAME OF PARTS	RMKS
45	S14695001	1	バルブユニットSLT	VALVE UNIT (SLT)	
45-1	S08151000	1	マニホルドS-2	MANIHOLD S-2	
45-2	S08155000	2	バルブVZ3140	VALVE VZ3140	
45-3	140682001	1	サイレンサー	SILENCER	
45-4	153274001	2	1/8トメセン	CAP 1/8	
45-5	S01522000	1	ハーフユニオン	HALF UNION	
45-6	S04897000	1	メクラセン	BLIND CAP	
46	018503022	2	アナボルト5X30	BOLT 5X30	
47	028050242	2	ハネサガネ2-5	SPRING WASHER 2-5	
48	S14146000	1	ブランチUY-6	BRANCH UY-6	
49	S14697000	1	エアホース6-C	AIR TUBE 6-C	

S. 電装品関係/Power supply equipment mechanism/Stromversorgung/Mécanisme de l'équipement en alimentation électrique/Mecanismo del equipo de alimentación de corriente

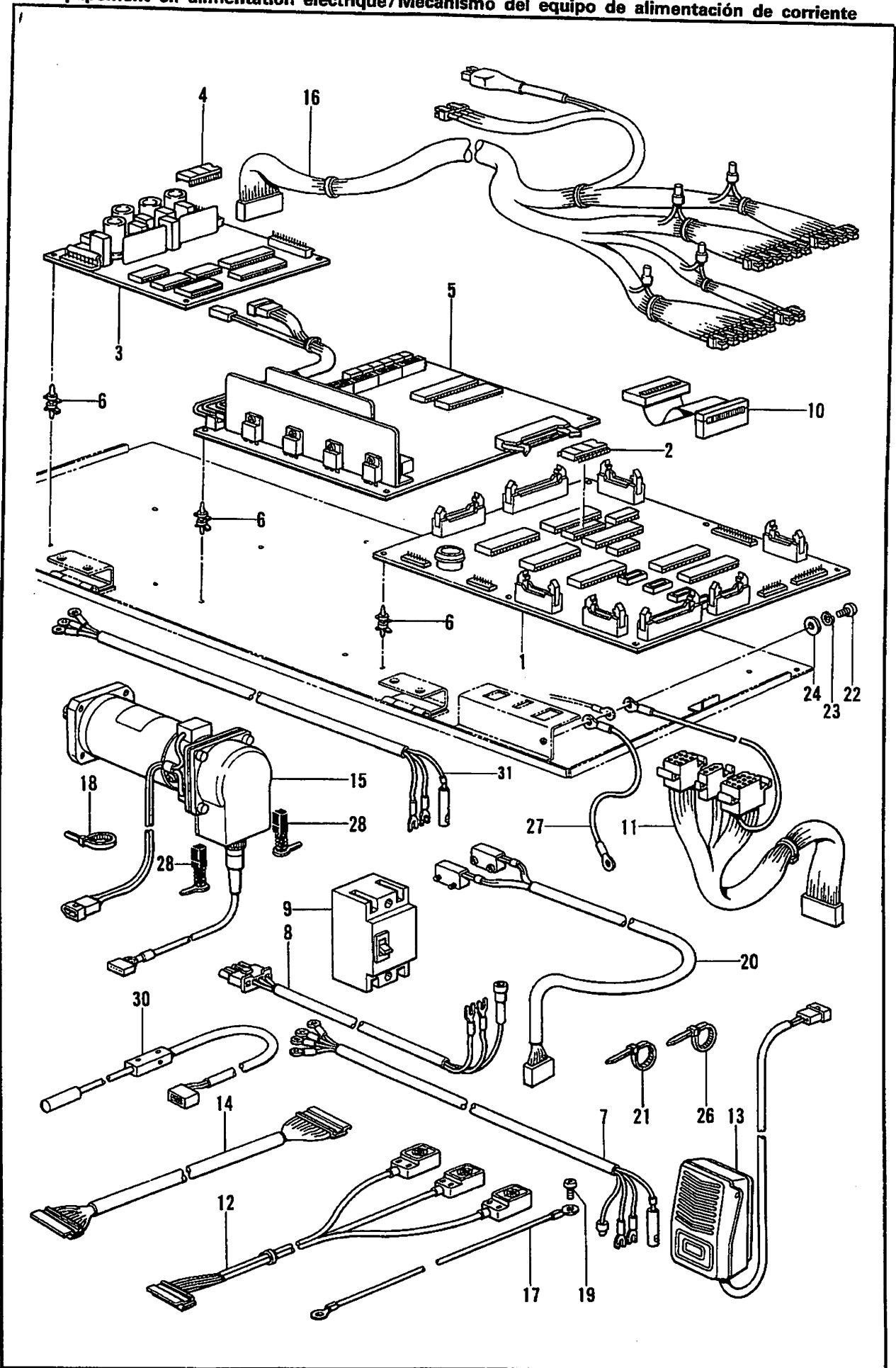

S. 電装品関係/Power supply equipment mechanism/Stromversorgung/Mécanisme de l'équipement en alimentation électrique/Mecanismo del equipo de alimentación de corriente

REF.NO.	CODE	Q'TY	品名	NAME OF PARTS	RMKS
1	S14412000	1	キハ"ンB439048クミ	CIRCUIT BOARD (B439048) ASSEMBLY	
2	S14413000	1	PROM612-1クミ	PROM612-1 ASSEMBLY	
3	S15361001	1	キハ"ンB439049クミ	CIRCUIT BOARD (B439049) ASSEMBLY	
4	S08103000	1	PROM600-2クミ	PROM 600-2 ASSEMBLY	
5	S08098000	1	DCモータキハ"ンクミ	D.C.MOTOR CIRCUIT BOARD ASSEMBLY	
6	S00554000	14	サポ-ト6NS	SUPPORTER 6NS	
7	S08086000	1	POWハーネスAクミ 3ソウ	POWER HARNESS (A) ASSEMBLY (3 PHASE)	
8	S08105000	1	POWハーネスBクミ	POWER HARNESS (B) ASSEMBLY	
9	S08106000	1	ブレーカ5A	BREAKER (5A)	
10	S08108000	1	PCBハーネス34Pクミ	PCB HARNESS (34P) ASSEMBLY	
11	S08109000	1	PCBハーネス17Pクミ	PCB HARNESS (17P) ASSEMBLY	
12	S08110000	1	キンセツスイッチクミ	PROXIMTY SWITCH ASSEMBLY	
13	S08114001	1	スタートSWクミ	START SWITCH ASSEMBLY	
14	S08115000	1	PCBハーネス15Pクミ	PCB HARNESS (15P) ASSEMBLY	
15	S08116000	1	DCモータクミ	D.C.MOTOR ASSEMBLY	
16	S14414001	1	バルブ"ハーネスクミ	VALVE HARNESS ASSEMBLY	
17	S08113000	1	アースコード"	EARTH CORD	
18	S04557000	3	バンドタイPLTIM	BAND PLTIM	
19	062680616	1	ナヘ"コ437-40X6	SCREW 4.37X6	
20	S08121000	1	フラップ"センサークミ	FLAP SENSOR ASSEMBLY	
21	S04557000	6	バンドタイPLTIM	BAND PLTIM	
22	062400806	1	ナヘ"コ4X8	SCREW 4X8	
23	028040243	1	ハ"ネサ"ガ"ネ2-4	SPRING WASHER 2-4	
24	025040233	1	ヒラサ"ガ"ネチユウ4	PLAIN WASHER 4	
26	149809000	3	タイラップL	BEAD BAND (LARGE)	
27	S11337000	1	アースコード"	EARTH CORD	
28	S11338000	1	DCモータブラシクミ	D.C. MOTOR BRUSH ASSEMBLY	
30	S14118000	1	コーナーメスセンサークミ	CORNER KNIFE SENSOR ASSEMBLY	
31	S16198000	1	POWハーネスA タンソウ	POWER HARNESS (1 PHASE)	

T. 布制御関係/Cloth control system mechanism/StoffführungsVorrichtung/  
 Mécanisme de la système de contrôle du tissu/Mecanismo de la sistema de control de tela

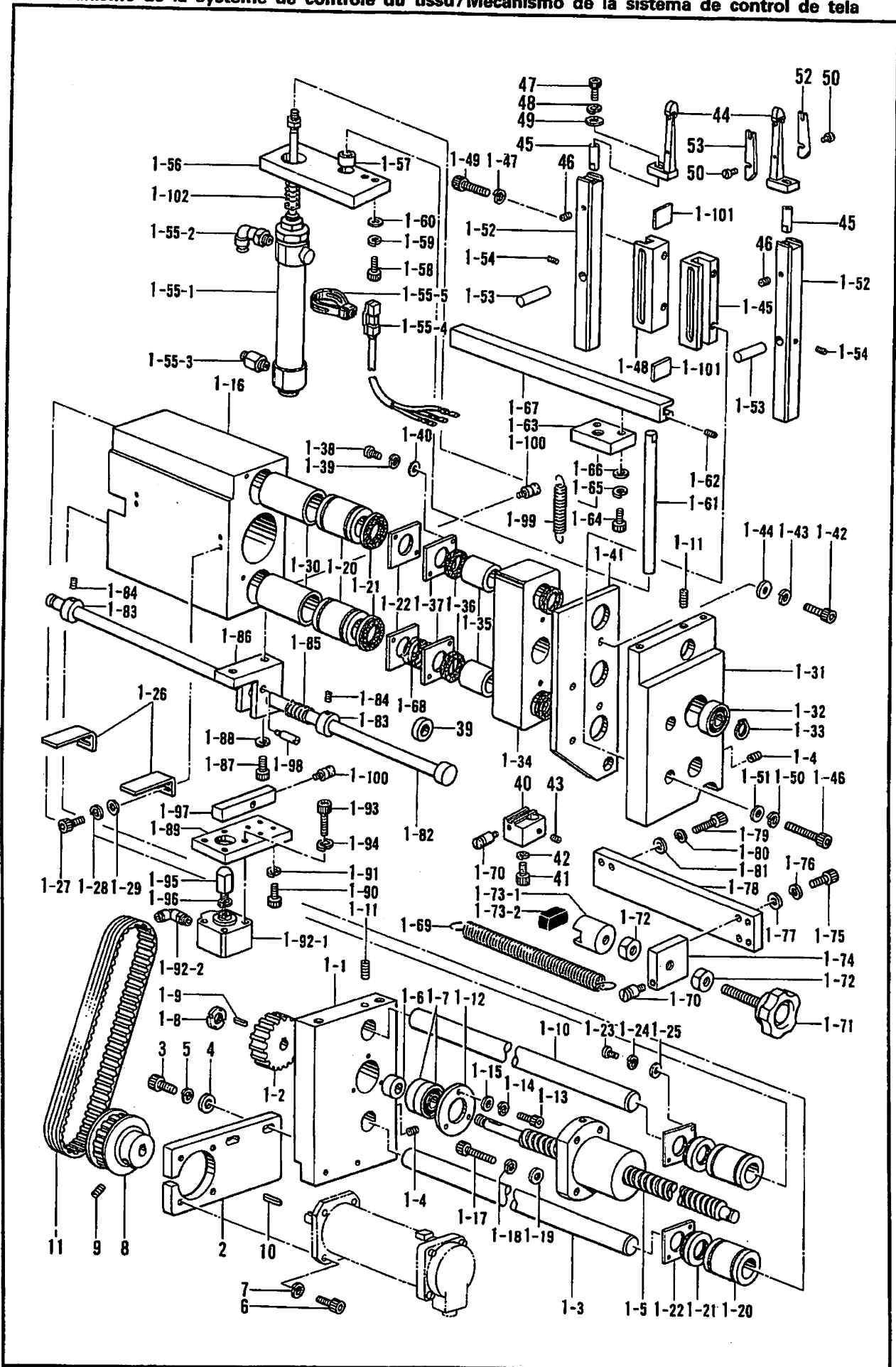

T. 布制御関係/Cloth control system mechanism/StoffführungsVorrichtung/  
 Mécanisme de la système de contrôle du tissu/Mecanismo de la sistema de control de tela

REF.NO.	CODE	Q'TY	品名	NAME OF PARTS	RMKS
1	S08282101	1	オクリソウチクミ	FEED DEVICE ASSEMBLY	
1-1	S08284001	1	ボールネジ"サホ"ートL	BALL SCREW SUPPORTER (LEFT)	
1-2	S08286000	1	タイミング"フー"リA	TIMING PULLEY (A)	
1-3	S08289001	1	スライ"シ"クシタ	SLIDE SHAFT LOWER	
1-4	014060622	2	アナトメネジ"6X6クホ"ミ	SET SCREW 6X6	
1-5	S08290001	1	ボールネジ"	BALL SCREW	
1-6	S08291001	1	カラ	COLLAR	
1-7	S08292000	1	タマシ"クウケ7201ADF	BEARING 7201ADF	
1-8	073010002	2	シ"クウケナツトAN01	BEARING NUT AN01	
1-9	S08280000	1	キー4X4X16	KEY 4X4X16	
1-10	S08293001	1	スライ"シ"クウエ	SLIDE SHAFT UPPER	
1-11	014060622	2	アナトメネジ"6X6クホ"ミ	SET SCREW 6X6	
1-12	S08294001	1	へ"アリンク"オサエ	BEARING PRESSER	
1-13	018401222	3	アナボ"ルト4X12	BOLT 4X12	
1-14	028040242	3	ハ"ネサ"カ"ネチユウ4	SPRING WASHER 2-4	
1-15	025040232	3	ヒラサ"カ"ネチユウ4	PLAIN WASHER 4	
1-16	S08295000	1	オオオサエイト"ウタ"イ	CARRIAGE FEED MOVABLE BASE	
1-17	018062522	4	アナボ"ルト6X25	BOLT 6X25	
1-18	028060242	4	ハ"ネサ"カ"ネ 2-6	SPRING WASHER 2-6	
1-19	025060232	4	ヒラサ"カ"ネチユウ 6	PLAIN WASHER 6	
1-20	S09157000	4	リニアボ"ールへ"アリンク"	LINEAR BALL BEARING	
1-21	S08400000	4	フェルトシール	FELT SEAL	
1-22	S08300001	4	へ"アリンク"オサエ	BEARING PRESSER	
1-23	062300616	8	ナへ"コM3X6	SCREW M3X6	
1-24	028030243	8	ハ"ネサ"カ"ネ2-3	SPRING WASHER 2-3	
1-25	025030233	8	ヒラサ"カ"ネチユウ3	PLAIN WASHER 3	
1-26	S08301001	2	センサーカンチイタ	SENSOR PERCEIVE PLATE	
1-27	018300822	4	アナボ"ルト3X8	BOLT 3X8	
1-28	028030242	4	ハ"ネサ"カ"ネ2-3	SPRING WASHER 2-3	
1-29	025030232	4	ヒラサ"カ"ネチユウ3	PLAIN WASHER 3	
1-30	S08304001	2	スヘ"ーサ	SPACER	
1-31	S14799001	1	ボールネジ"サホ"ートR	BALL SCREW SUPPORT (RIGHT)	
1-32	S08306000	1	タマシ"クウケ6201ZZ	BEARING 6201ZZ	
1-33	048120142	1	トメワシ"クヨウC12	STOP RING C12	
1-34	S08309001	1	コーナメスイト"ウタ"イ	CORNER KNIFE MOVABLE BASE	
1-35	S08298000	2	リニアボ"ールへ"アリンク"	LINER BALL BEARING	
1-36	S15163000	4	フェルトシール	FELT SEAL	
1-37	S08300001	2	へ"アリンク"オサエ	BEARING PRESSER	
1-38	062300616	4	ナへ"コM3X6	SCREW M3X6	
1-39	028030243	4	ハ"ネサ"カ"ネ2-3	SPRING WASHER 2-3	
1-40	025030233	4	ヒラサ"カ"ネチユウ3	PLAIN WASHER 3	
1-41	S08310001	1	コーナメスタ"イ	CORNER KNIFE BASE	
1-42	018501622	2	アナボ"ルト5X16	BOLT 5X16	
1-43	028050242	2	ハ"ネサ"カ"ネ2-5	SPRING WASHER 2-5	
1-44	025050232	2	ヒラサ"カ"ネチユウ5	PLAIN WASHER 5	
1-45	S08317001	1	スライ"カ"イト"R	SLIDE GUIDE (RIGHT)	
1-46	018503022	2	アナボ"ルト5X30	BOLT 5X30	
1-47	028050242	2	ハ"ネサ"カ"ネ2-5	SPRING WASHER 2-5	
1-48	S08318001	1	スライ"カ"イト"L	SLIDE GUIDE (LEFT)	
1-49	018502022	2	アナボ"ルト5X20	BOLT 5X20	
1-50	028050242	2	ハ"ネサ"カ"ネ2-5	SPRING WASHER 2-5	
1-51	025050232	2	ヒラサ"カ"ネチユウ5	PLAIN WASHER 5	
1-52	S14754001	2	スライ"ター	SLIDER	
1-53	S08320001	2	オシアケ"ピン	PIN	
1-54	014400422	2	アナトメネジ"4X4クホ"ミ	SET SCREW 4X4	
1-55	S08323000	1	シリンダ"クミ	CYLINDER ASSEMBLY	
1-55-1	S08324000	1	シリンダ"20X75	CYLINDER 20X75	
1-55-2	S06866000	1	バルブ"	VALVE	
1-55-3	S04910000	1	ハーフユニオン	HALF UNION	
1-55-4	S08488000	1	シリンダ"センサー	CYLINDER SENSOR	
1-55-5	S08501000	1	トリツクカナク"20	FITTING CLAMP 20	
1-56	S08325001	1	シリンダ"トリツクタ"イ	CYLINDER FITTING BASE	

T. 布制御関係/Cloth control system mechanism/Stoffführungsvorrichtung/  
 Mécanisme de la système de contrôle du tissu/Mecanismo de la sistema de control de tela

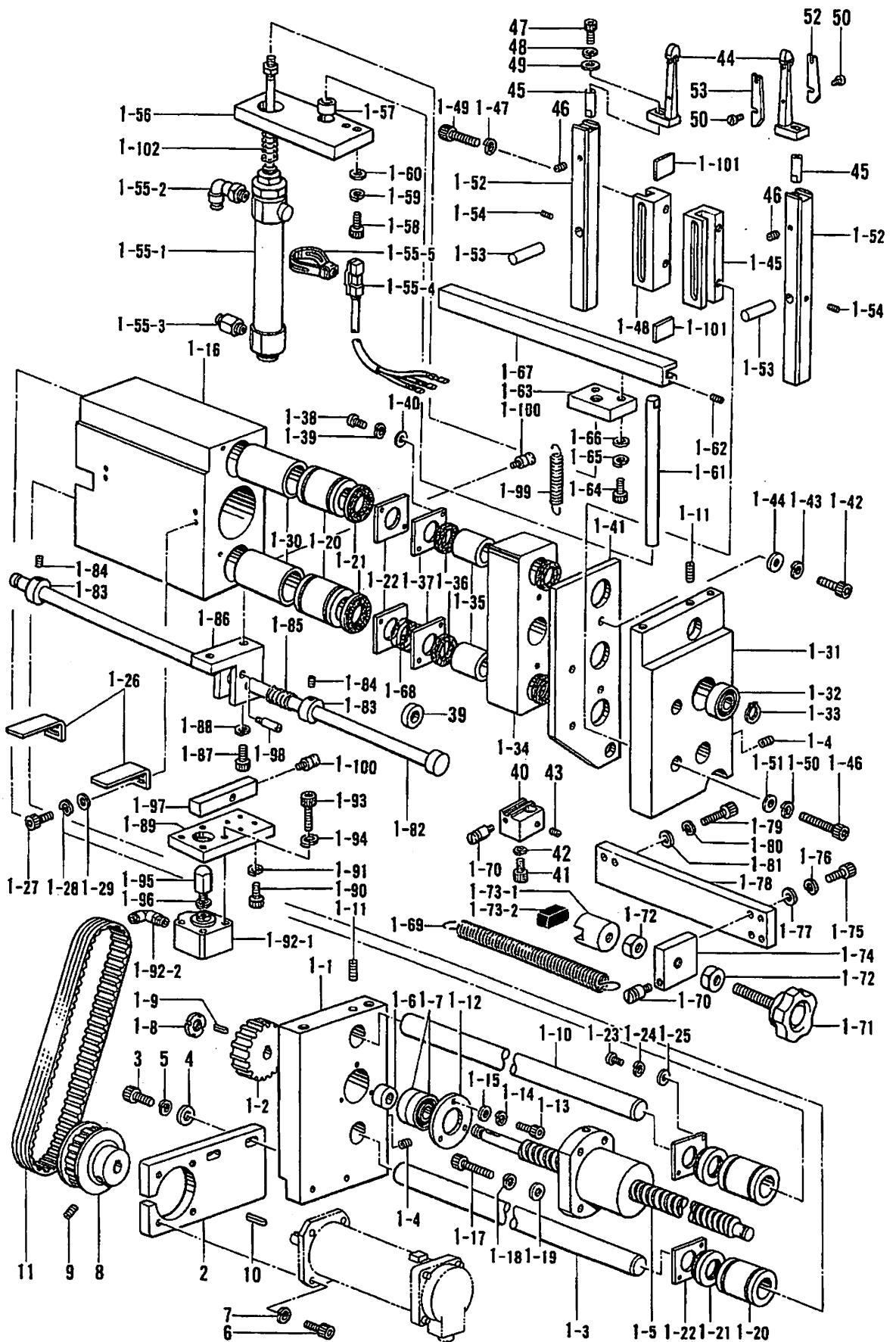

T. 布制御関係/Cloth control system mechanism/StoffführungsVorrichtung/  
 Mécanisme de la système de contrôle du tissu/Mecanismo de la sistema de control de tela

REF.NO.	CODE	QTY	ヒンメイ	NAME OF PARTS	RMKS
1-57	S08326000	1	ト"ライハ"アリンク	DRY BEARING	
1-58	018062522	2	アナボ"ルト6X25	BOLT 6X25	
1-59	028060242	2	ハ"ネサ"カ"ネ 2-6	SPRING WASHER 2-6	
1-60	025060232	2	ヒラサ"カ"ネチユウ 6	PLAIN WASHER 6	
1-61	S08327001	1	マフリト"メシ"ク	BAFFLE WHIRL-STOP SHAFT	
1-62	014500522	1	アナトメネシ"5クホ"ミ	SET SCREW 5	
1-63	S08328001	1	シリンダ"レンケツイタ	CYLINDER CONNECTING PLATE	
1-64	018501622	2	アナボ"ルト5X16	BOLT 5X16	
1-65	028050242	2	ハ"ネサ"カ"ネ2-5	SPRING WASHER 2-5	
1-66	025050232	2	ヒラサ"カ"ネチユウ-5	PLAIN WASHER 5	
1-67	S08329001	1	コーナメスオシアゲ"イタ	CORNER KNIFE LIFTING PLATE	
1-68	S08303001	1	アツシユクハ"ネ	SPRING	
1-69	S08308001	1	ヒツハ"リハ"ネ	SPRING	
1-70	S08509001	2	ハ"ネカケ	SPRING HOOK	
1-71	S08180000	1	ノブ"ボ"ルトM8X50	NOB BOLT M8X50	
1-72	021080206	2	2シユナツト8	NUT 8	
1-73	S09155000	1	マグ"ネットホルタ"ークミ	MAGNET HOLDER ASSEMBLY	
1-73-1	S09156000	1	マグ"ネットホルタ"	MAGNET HOLDER	
1-73-2	112525000	1	シユウシ"ンマグ"ネット	MAGNET	
1-74	S15201001	1	ハント"ルタ"イ	HANDLE BASE	
1-75	018061622	2	アナボ"ルト6X16	BOLT 6X16	
1-76	028060242	2	ハ"ネサ"カ"ネ 2-6	SPRING WASHER 2-6	
1-77	025060232	2	ヒラサ"カ"ネチユウ 6	PLAIN WASHER 6	
1-78	S09153001	1	チヨウセツタ"イ	ADJUSTING BASE	
1-79	018502022	2	アナボ"ルト5X20	BOLT 5X20	
1-80	028050242	2	ハ"ネサ"カ"ネ2-5	SPRING WASHER 2-5	
1-81	025050232	2	ヒラサ"カ"ネチユウ-5	PLAIN WASHER 5	
1-82	S08297001	1	イチキ"メロツト"	POSITIONING ROD	
1-83	S08296001	2	セツトカラ-	SET COLLAR	
1-84	014500522	4	アナトメネシ"5クホ"ミ	SET SCREW 5	
1-85	148555001	1	シユレハ"ーモト"シハ"ネ	SPRING	
1-86	S15590001	1	クランプ"タ"イ	CLAMP BASE	
1-87	018501422	2	アナボ"ルト5X14	BOLT 5X14	
1-88	028050242	2	ハ"ネサ"カ"ネ2-5	SPRING WASHER 2-5	
1-89	S13638001	1	シリンダ"トリツケイタ	CYLINDER FITTING PLATE	
1-90	018401622	4	アナボ"ルト4X16	BOLT 4X16	
1-91	028040242	4	ハ"ネサ"カ"ネチユウ4	SPRING WASHER 2-4	
1-92	S13639000	1	シリンダ"クミ	CYLINDER ASSEMBLY	
1-92-1	S13640000	1	シリンダ"32X5	CYLINDER 32X5	
1-92-2	S06886000	1	ツキ"テ1/8-4	JOINT 1/8-4	
1-93	018062022	4	アナボ"ルト6X20	BOLT 6X20	
1-94	028060242	4	ハ"ネサ"カ"ネ 2-6	SPRING WASHER 2-6	
1-95	S13641001	1	プ"ツシヤ	PUSHER	
1-96	028060242	1	ハ"ネサ"カ"ネ 2-6	SPRING WASHER 2-6	
1-97	S15591001	1	クランプレハ"ー	CLAMP LEVER	
1-98	S08315000	1	シテンシ"ク	FULCRUM SHAFT	
1-99	156292001	1	ストツハ"ーヒキハ"ネ	STOPPER COIL SPRING	
1-100	S08509001	2	ハ"ネカケ	SPRING HOOK	
1-101	S09170000	2	クツシヨング"ム	RUBBER CUSHION	
1-102	S09685001	1	アツシユクハ"ネ	SPRING	
2	S08285001	1	モ-ターブ"ラケツト	MOTOR BRACKET	
3	018062522	2	アナボ"ルト6X25	BOLT 6X25	
4	025060232	2	ヒラサ"カ"ネチユウ 6	PLAIN WASHER 6	
5	028060242	2	ハ"ネサ"カ"ネ 2-6	SPRING WASHER 2-6	
6	018501622	4	アナボ"ルト5X16	BOLT 5X16	
7	028050242	4	ハ"ネサ"カ"ネ2-5	SPRING WASHER 2-5	
8	S08287000	1	タイミンク"フ-ーリB	TIMING BELT WHEEL (B)	
9	014501222	2	アナトメネシ"5X12ヒラ	SCREW 5X12	
10	S10540000	1	キー-3X3X20	KEY 3X3X20	
11	S08288000	1	タイミンク"ヘル"ト	TIMING BELT	
39	S15202001	1	センサス"ペ-ーサ	SENSOR SPACER	
40	S15203000	1	センサブ"ラケツト	SENSOR BRACKET	



T. 布制御関係/Cloth control system mechanism/Stoffführungsvorrichtung/  
 Mécanisme de la système de contrôle du tissu/Mecanismo de la sistema de control de tela

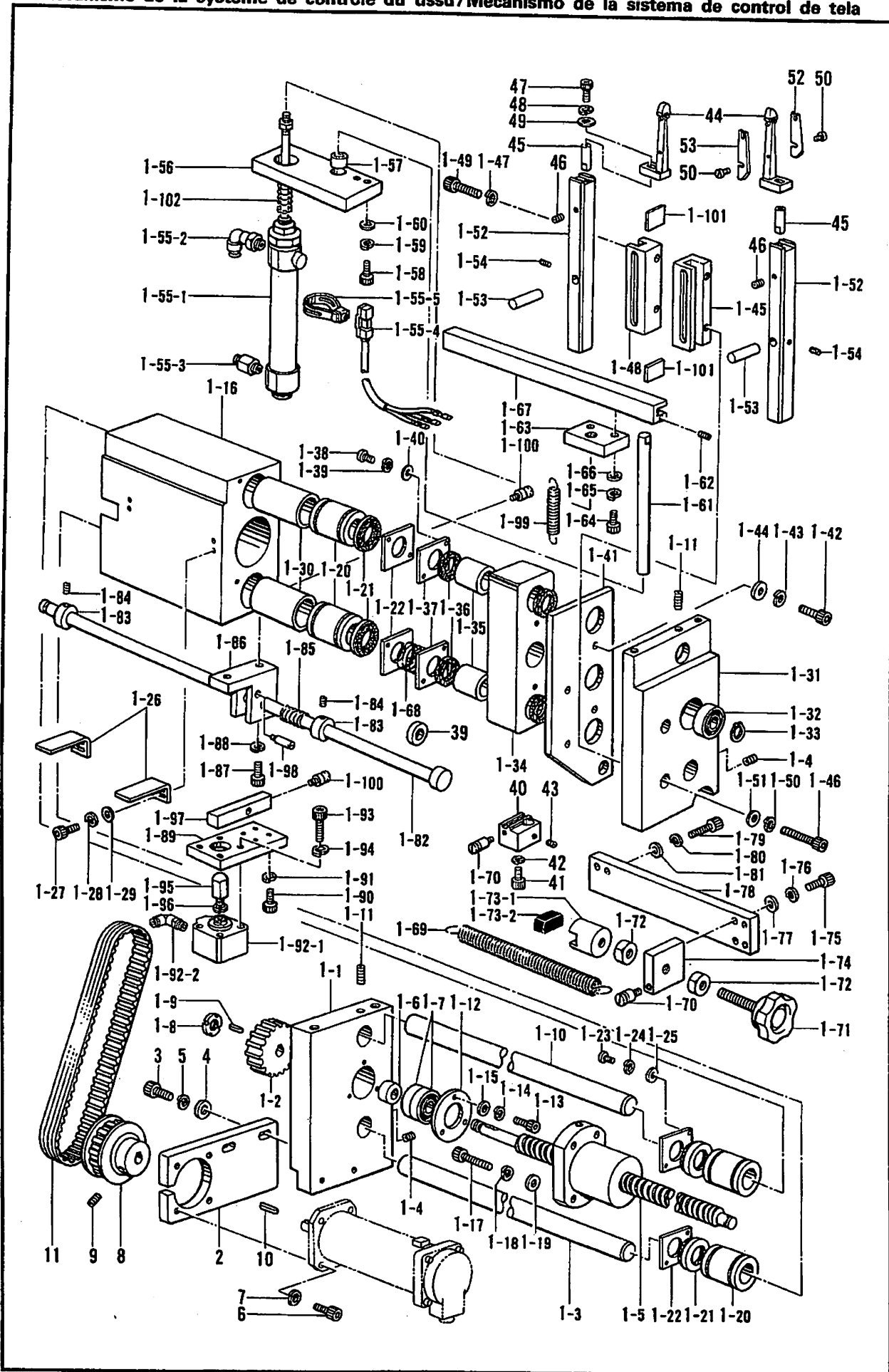

T. 布制御関係/Cloth control system mechanism/Stoffführungsvorrichtung/  
 Mécanisme de la système de contrôle du tissu/Mecanismo de la sistema de control de tela

REF.NO.	CODE	Q'TY	ヒンメイ	NAME OF PARTS	RMKS
41	018402032	1	アナボ"ルト4X20	BOLT 4X20	
42	028040242	1	ハ"ネサ"カ"ネ 2-4	SPRING WASHER 2-4	
43	014300322	1	アナクホ"ミ3X3	SET SCREW 3X3	
44	*	2	メスタ"イクミ	BASE ASSEMBLY	
45	S14753001	2	メスタ"イシ"ク	KNIFE BASE SHAFT	
46	014400422	2	アナトメネシ"4X4クホ"ミ	SET SCREW 4X4	
47	018401222	2	アナボ"ルト4X12	BOLT 4X12	
48	028040242	2	ハ"ネサ"カ"ネ2-4	SPRING WASHER 2-4	
49	025040232	2	ヒラサ"カ"ネチユウ4	PLAIN WASHER 4	
50	111140002	4	シメネシ"2.38	SCREW 2.38	
52	*	2	コーナーメス	CORNER KNIFE	
53	*	2	コーナーメス	CORNER KNIFE	

T. 布制御関係/Cloth control system mechanism/Stoffführungsrichtung/  
 Mécanisme de la système de contrôle du tissu/Mecanismo de la sistema de control de tela

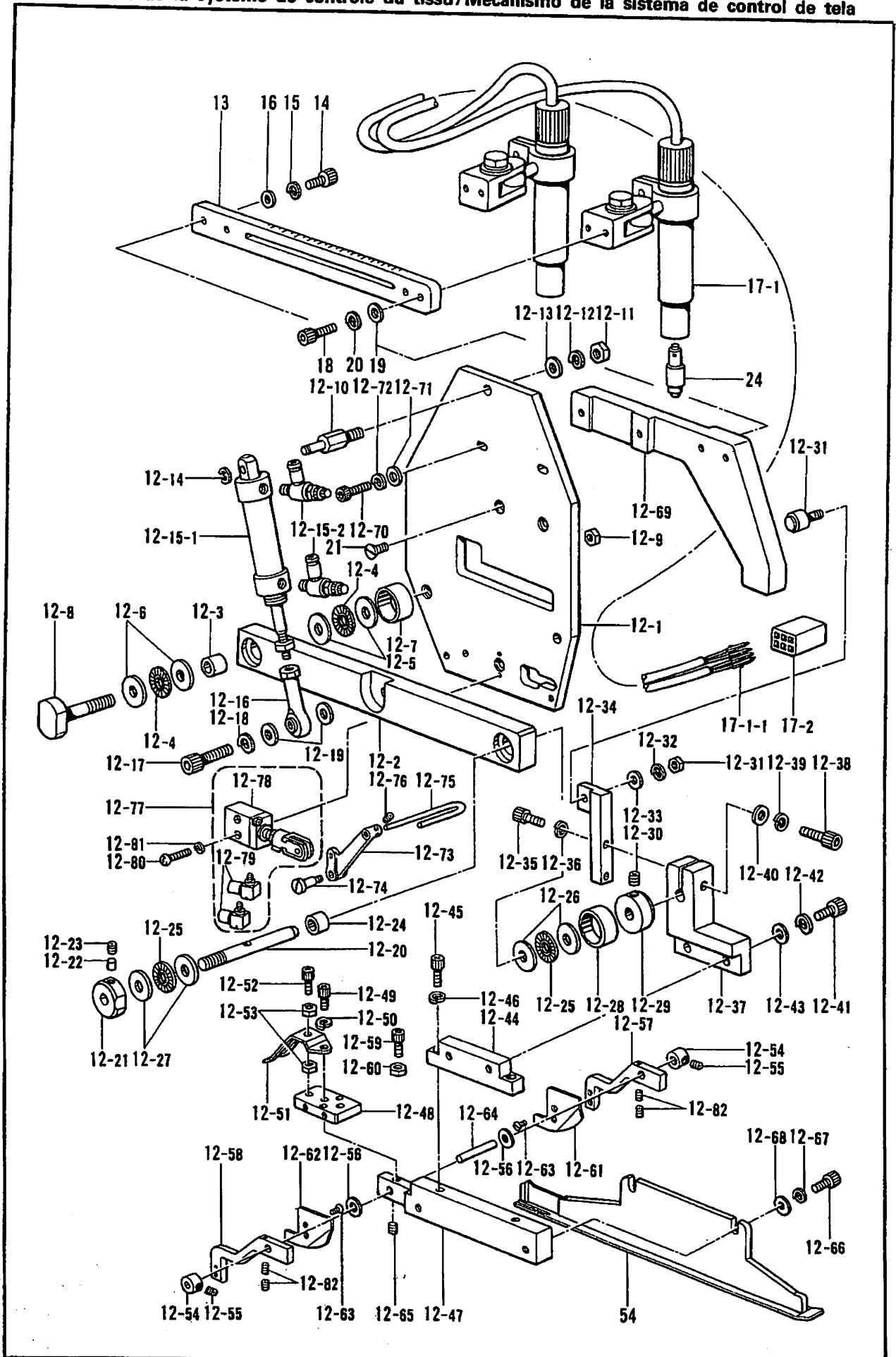

T. 布制御関係/Cloth control system mechanism/Stoffführungsvorrichtung/  
 Mécanisme de la système de contrôle du tissu/Mecanismo de la sistema de control de tela

REF.NO.	CODE	Q'TY	ヒンメイ	NAME OF PARTS	RMKS
12	S14698001	1	メンイタユニットクミ	FACE PLATE UNIT ASSEMBLY	
12-1	S14699001	1	メンイタ	FACE PLATE	
12-2	S14700001	1	アーム	ARM	
12-3	S08332000	1	ト"ライハ"アリング	DRY BEARING	
12-4	S08238000	2	スラストハ"アリング"	THRUST BEARING	
12-5	S08239000	2	スラストワッシャ	THRUST WASHER	
12-6	S08240000	2	スラストワッシャ	THRUST WASHER	
12-7	S08342001	1	スラストハ"アリング"カバー	THRUST BEARING COVER	
12-8	S08333001	1	シテンシク	FULCRUM SHAFT	
12-9	021120304	1	ナット3シユ12	NUT 12	
12-10	S08360001	1	シリンダ"トリツケ"シク	CYLINDER FITTING SHAFT	
12-11	021080206	1	2シユナット8	NUT 8	
12-12	028080242	1	ハ"ネサ"ガ"ネ2-8	SPRING WASHER 2-8	
12-13	025080232	1	ヒラサ"ガ"ネチユウ8	PLAIN WASHER 8	
12-14	048040342	1	トメフE4	STOP RING E4	
12-15	S08335000	1	シリンダ"クミ	CYLINDER ASSEMBLY	
12-15-1	S08336000	1	シリンダ"20X35	CYLINDER 20X35	
12-15-2	S06898000	2	スピ"コンツキ"テ1/8-4	SPEED CONTROLLER JOINT 1/8-4	
12-16	S08352000	1	ロツト"エント"	ROD END	
12-17	018082522	1	アナボ"ルト8X25	BOLT 8X25	
12-18	028080242	1	ハ"ネサ"ガ"ネ2-8	SPRING WASHER 2-8	
12-19	025080232	2	ヒラサ"ガ"ネチユウ8	PLAIN WASHER 8	
12-20	S08341001	1	シ"ヨウキ"シテンシク	BINDER FULCRUM SHAFT	
12-21	S08338001	1	ヨアツナツト	PRE-LOAD NUT	
12-22	S08339001	1	ユルミト"メ	LOOSENESS STOP	
12-23	014060622	1	アナトメネシ"6X6クホ"ミ	SET SCREW 6X6	
12-24	S08332000	1	ト"ライハ"アリング	DRY BEARING	
12-25	S08238000	2	スラストハ"アリング"	THRUST BEARING	
12-26	S08239000	2	スラストワッシャ	THRUST WASHER	
12-27	S08240000	2	スラストワッシャ	THRUST WASHER	
12-28	S08334001	1	ハ"アリング"カバー	BEARING COVER	
12-29	S08340001	1	セツトカラー	SET COLLAR	
12-30	014060622	1	アナトメネシ"6X6クホ"ミ	SET SCREW 6X6	
12-31	S08343000	1	カムフオロフ	CAM FOLLOWER	
12-32	028050242	1	ハ"ネサ"ガ"ネ2-5	SPRING WASHER 2-5	
12-33	025050232	1	ヒラサ"ガ"ネチユウ-5	PLAIN WASHER 5	
12-34	S08344001	1	カムフオロア"トリツケ"ホ"ウ	CAM FOLLOWER SETTING BAR	
12-35	018501622	2	アナボ"ルト5X16	BOLT 5X16	
12-36	028050242	2	ハ"ネサ"ガ"ネ2-5	SPRING WASHER 2-5	
12-37	S08345001	1	シ"ヨウキ"トリツケイタA	BINDER SETTING PLATE (A)	
12-38	018062022	1	アナボ"ルト6X20	BOLT 6X20	
12-39	028060242	1	ハ"ネサ"ガ"ネ 2-6	SPRING WASHER 2-6	
12-40	025060232	1	ヒラサ"ガ"ネチユウ 6	PLAIN WASHER 6	
12-41	018501622	2	アナボ"ルト5X16	BOLT 5X16	
12-42	028050242	2	ハ"ネサ"ガ"ネ2-5	SPRING WASHER 2-5	
12-43	025050232	2	ヒラサ"ガ"ネチユウ-5	PLAIN WASHER 5	
12-44	S08346001	1	シ"ヨウキ"トリツケイタB	BINDER SETTING PLATE (B)	
12-45	018501622	2	アナボ"ルト5X16	BOLT 5X16	
12-46	028050242	2	ハ"ネサ"ガ"ネ2-5	SPRING WASHER 2-5	
12-47	S08347001	1	シ"ヨウキ"トリツケイタC	BINDER SETTING PLATE (C)	
12-48	S08348001	1	イタハ"ネ"イ	PLATE SPRING BASE	
12-49	018301222	2	アナボ"ルト3X12	BOLT 3X12	
12-50	028030242	2	ハ"ネサ"ガ"ネ2-3	SPRING WASHER 2-3	
12-51	S08349001	1	イタハ"ネ	PLATE SPRING	
12-52	018301222	1	アナボ"ルト3X12	BOLT 3X12	
12-53	021300303	2	ナツト3シユ3	NUT 3	
12-54	S08350001	2	セツトカラー	SET COLLAR	
12-55	014400422	4	アナトメネシ"4X4クホ"ミ	SET SCREW 4X4	
12-56	S08356001	*	スヘーサ	SPACER	
12-57	S14801001	1	キシ"カ"イト"アームR	CLOTH GUIDE ARM (RIGHT)	
12-58	S14800001	1	キシ"カ"イト"アームL	CLOTH GUIDE ARM (LEFT)	
12-59	018301222	2	アナボ"ルト3X12	BOLT 3X12	

T. 布制御関係/Cloth control system mechanism/Stoffführungsvorrichtung/  
 Mécanisme de la système de contrôle du tissu/Mecanismo de la sistema de control de tela

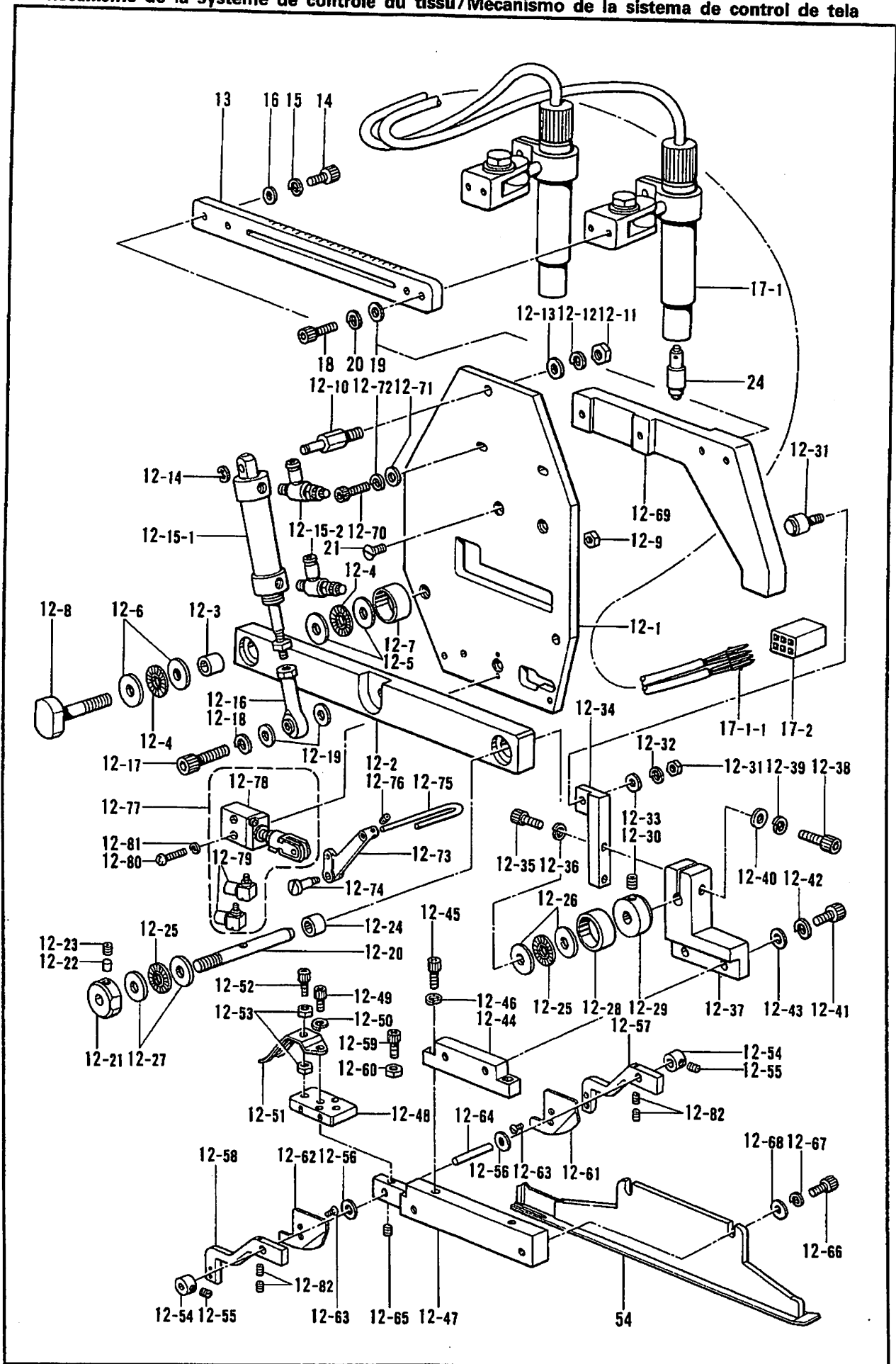

T. 布制御関係/Cloth control system mechanism/Stoffführungsvorrichtung/  
 Mécanisme de la système de contrôle du tissu/Mecanismo de la sistema de control de tela

REF.NO.	CODE	Q'TY	ヒンメイ	NAME OF PARTS	RMKS
12-60	021300303	2	ナツト3シユ3	NUT 3	
12-61	S14701000	1	キシ"カ"イト"R	CLOTH GUIDE (RIGHT)	
12-62	S14702000	1	キシ"カ"イト"L	CLOTH GUIDE (LEFT)	
12-63	061020506	4	サラユ2X5	SCREW 2X5	
12-64	S08355001	1	シデンシ"ク	FULCRUM SHAFT	
12-65	014400422	1	アナトメネシ"4X4クホ"ミ	SET SCREW 4X4	
12-66	018501022	2	アナホ"ルト5X10	BOLT 5X10	
12-67	028050242	2	ハ"ネサ"カ"ネ2-5	SPRING WASHER 2-5	
12-68	025050232	2	ヒラサ"カ"ネチユウ-5	PLAIN WASHER 5	
12-69	S08364001	1	ミソ"カム	FLUTE CAM	
12-70	018501622	2	アナホ"ルト5X16	BOLT 5X16	
12-71	025050232	2	ヒラサ"カ"ネチユウ-5	PLAIN WASHER 5	
12-72	028050242	2	ハ"ネサ"カ"ネ2-5	SPRING WASHER 2-5	
12-73	S14703001	1	イトクリタ"シウデ"	THREAD TAKE-UP ARM	
12-74	141598001	1	タ"ンネシ"4.76	STUD SCREW 4.76	
12-75	S08372001	1	イトクリタ"シ	THREAD TAKE-UP	
12-76	014300332	2	アナクホ"ミ3X3	SCREW 3X3	
12-77	S14704100	1	シリンダ"クミ	CYLINDER ASSEMBLY	
12-78	S14705000	1	シリンダ"10X5	CYLINDER 10X5	
12-79	S16603000	2	コテイシホ"リツキエルホ"	THROTTLE TUBE ELBOW	
12-80	062301606	2	ナハ"コ 3X16	SCREW 3X16	
12-81	028030243	2	ハ"ネサ"カ"ネ2-3	SPRING WASHER 2-3	
12-82	014300522	4	トメネシ"3X5クホ"ミ	SET SCREW 3X5	
13	S08365001	1	ランプト"タイ	LAMP BRACKET	
14	018501622	2	アナホ"ルト5X16	BOLT 5X16	
15	028050242	2	ハ"ネサ"カ"ネ2-5	SPRING WASHER 2-5	
16	025050232	2	ヒラサ"カ"ネチユウ-5	PLAIN WASHER 5	
17	S08502000	1	マーキング"ライトクミ	MARKING LIGHT ASSEMBLY	
17-1	S08367000	2	ライトマーカ	MARKING LIGHT	
17-1-1	S08017000	2	オスピン5006TL	MALE PIN 5006TL	
17-2	S08009000	1	コネクタ5025-06PI	CONNECTOR 5025-06PI	
18	018502022	4	アナホ"ルト5X20	BOLT 5X20	
19	025050232	4	ヒラサ"カ"ネチユウ-5	PLAIN WASHER 5	
20	028050242	4	ハ"ネサ"カ"ネ2-5	SPRING WASHER 2-5	
21	S01698001	3	サラネシ"5.95X12	SCREW 5.95X12	
24	S08137000	1	ランプ"5W	LAMP 5W	
54	*	1	シ"ヨウキ"クミ	BINDER	

T. 布制御関係/Cloth control system mechanism/Stoffführungsvorrichtung/  
 Mécanisme de la système de contrôle du tissu/Mecanismo de la sistema de control de tela

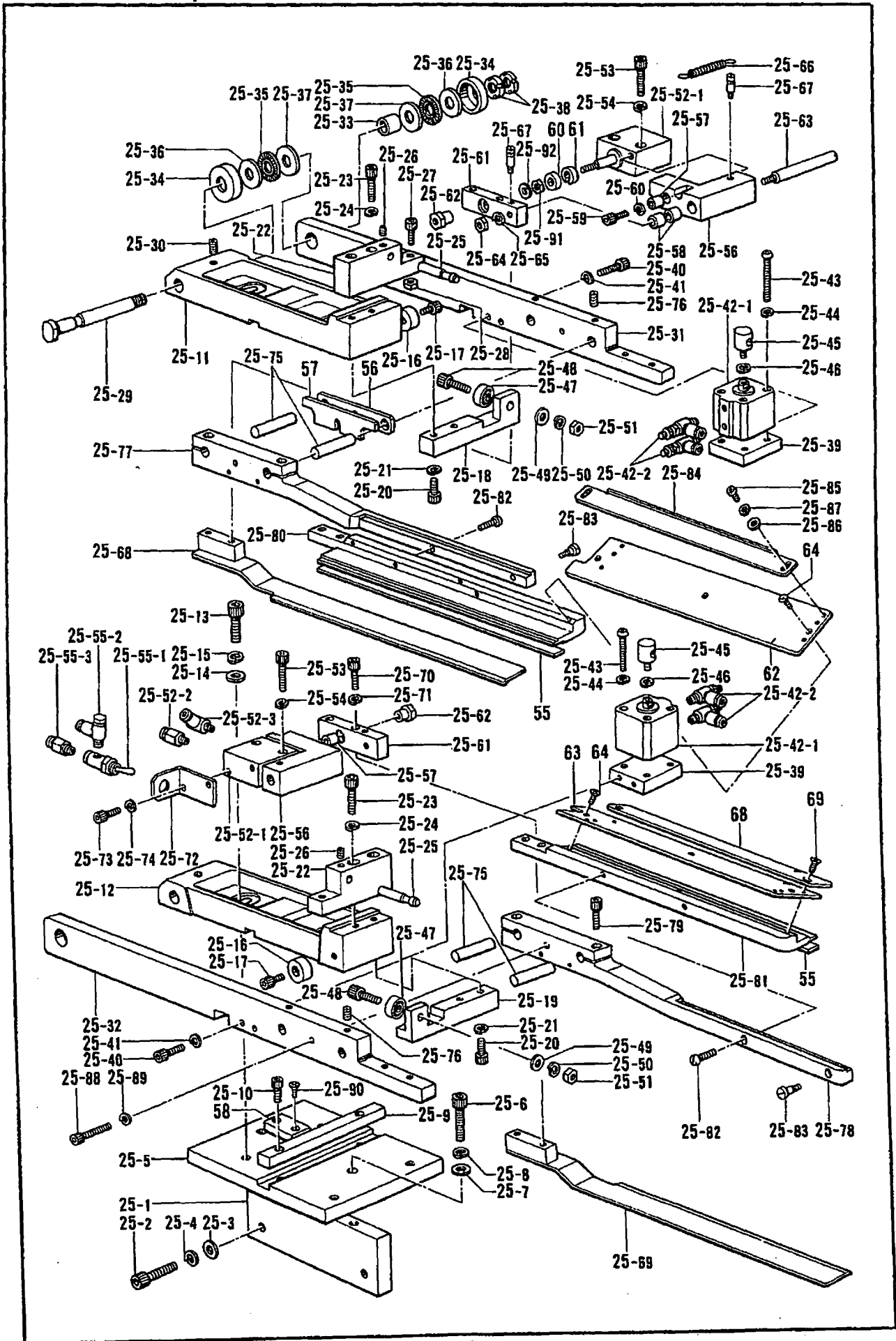

T. 布制御関係/Cloth control system mechanism/StoffführungsVorrichtung/  
 Mécanisme de la système de contrôle du tissu/Mecanismo de la sistema de control de tela

REF.NO.	CODE	Q'TY	ヒンメイ	NAME OF PARTS	RMKS
25	S08227001	1	オオオサエクミ	CARRIAGE FEED ASSEMBLY	
25-1	S08228001	1	オオオサエトリツケイタ	CARRIAGE FEED FITTING PLATE	
25-2	018083022	2	アナボ"ルト8X30	BOLT 8X30	
25-3	025080232	2	ヒラサ"カ"ネチユウ8	PLAIN WASHER 8	
25-4	028080242	2	ハ"ネサ"カ"ネ2-8	SPRING WASHER 2-8	
25-5	S08229001	1	オオオサエトリツケタ"イ	CARRIAGE FEED FITTING BASE	
25-6	018083022	2	アナボ"ルト8X30	BOLT 8X30	
25-7	025080232	2	ヒラサ"カ"ネチユウ8	PLAIN WASHER 8	
25-8	028080242	2	ハ"ネサ"カ"ネ2-8	SPRING WASHER 2-8	
25-9	S08230001	1	スライ"ガ"イト	SLIDE GUIDE	
25-10	018401022	2	アナボ"ルト4X10	BOLT 4X10	
25-11	S08231000	1	オオオサエイト"ウダ"イR	CARRIAGE FEED MOVABLE BASE (RIGHT)	
25-12	S08232000	1	オオオサエイト"ウダ"イL	CARRIAGE FEED MOVABLE BASE (LEFT)	
25-13	018082522	4	アナボ"ルト8X25	BOLT 8X25	
25-14	025080232	4	ヒラサ"カ"ネチユウ8	PLAIN WASHER 8	
25-15	028080242	4	ハ"ネサ"カ"ネ2-8	SPRING WASHER 2-8	
25-16	S08233000	2	スヘ"リ"カ"イト	SLIDE GUIDE	
25-17	018501022	2	アナボ"ルト5X10	BOLT 5X10	
25-18	S08245001	1	ガ"イト"ローラ"イR	GUIDE ROLLER BASE (RIGHT)	
25-19	S08246001	1	ガ"イト"ローラ"イL	GUIDE ROLLER BASE (LEFT)	
25-20	018501422	4	アナボ"ルト5X14	BOLT 5X14	
25-21	028050242	4	ハ"ネサ"カ"ネ2-5	SPRING WASHER 2-5	
25-22	S08248001	2	レンケツシ"クササエ	CONNECTING SHAFT SUPPORTER	
25-23	018502522	4	アナボ"ルト5X25	BOLT 5X25	
25-24	028050242	4	ハ"ネサ"カ"ネ2-5	SPRING WASHER 2-5	
25-25	S08247001	2	オサエロツト"	PRESSER ROD	
25-26	014500522	2	アノメネシ"5クホ"ミ	SET SCREW 5	
25-27	018502022	2	アナボ"ルト5X20	BOLT 5X20	
25-28	021500103	2	ナツト1シユ5	NUT 5	
25-29	S08234001	2	シデンシ"ク	FULCRUM SHAFT	
25-30	014501222	2	アノメネシ"5X12ヒラ	SCREW 5X12	
25-31	S08217001	1	オオオサエウデ"R	CARRIAGE FEED ARM (RIGHT)	
25-32	S08235001	1	オオオサエウデ"L	CARRIAGE FEED ARM (LEFT)	
25-33	S08332000	2	ト"ライ"ハ"アリング"	DRY BEARING	
25-34	S08237001	4	スラスト"ハ"アリング"カハ"	THRUST BEARING COVER	
25-35	S08238000	4	スラスト"ハ"アリング"	THRUST BEARING	
25-36	S08239000	4	スラストワツシヤ	THRUST WASHER	
25-37	S08240000	4	スラストワツシヤ	THRUST WASHER	
25-38	073010002	4	シ"クウケナツトAN01	BEARING NUT AN01	
25-39	S08241001	2	シリンタ"ーウケ	CYLINDER SUPPOTER	
25-40	018502022	4	アナボ"ルト5X20	BOLT 5X20	
25-41	028050242	4	ハ"ネサ"カ"ネ2-5	SPRING WASHER 2-5	
25-42	S08242000	2	シリンタ"クミ	CYLINDER ASSEMBLY	
25-42-1	S08252000	2	シリンタ"20X15	CYLINDER 20X15	
25-42-2	S08498000	4	スピ"コンツキ"テM5-4	SPEED CONTROLLER JOINT M5-4	
25-43	062304006	8	ナヘ"コ3X40	SCREW 3X40	
25-44	028030243	8	ハ"ネサ"カ"ネ2-3	SPRING WASHER 2-3	
25-45	S08142001	2	レンケツシ"ク	CONNECTING SHAFT	
25-46	028040243	2	ハ"ネサ"カ"ネ2-4	SPRING WASHER 2-4	
25-47	S08249000	2	ハ"アリング"MR626ZZ	BEARING MR626ZZ	
25-48	018062022	2	アナボ"ルト6X20	BOLT 6X20	
25-49	025060232	2	ヒラサ"カ"ネチユウ 6	PLAIN WASHER 6	
25-50	028060242	2	ハ"ネサ"カ"ネ 2-6	SPRING WASHER 2-6	
25-51	021080206	2	ナツト2シユ6	NUT 6	
25-52	S08250000	2	シリンタ"クミ	CYLINDER ASSEMBLY	
25-52-1	S08251000	2	シリンタ"16X20	CYLINDER 16X20	
25-52-2	S06882000	2	ツキ"テM5-4	JOINT M5-4	
25-52-3	S06883000	2	S"エルボ" M5-4	S-ELBOW M5-4	
25-53	018402522	4	アナボ"ルト4X25	BOLT 4X25	
25-54	028040242	4	ハ"ネサ"カ"ネチユウ4	SPRING WASHER 2-4	



T. 布制御関係 / Cloth control system mechanism / Stoffführungsvorrichtung /  
 Mécanisme de la système de contrôle du tissu / Mecanismo de la sistema de control de tela

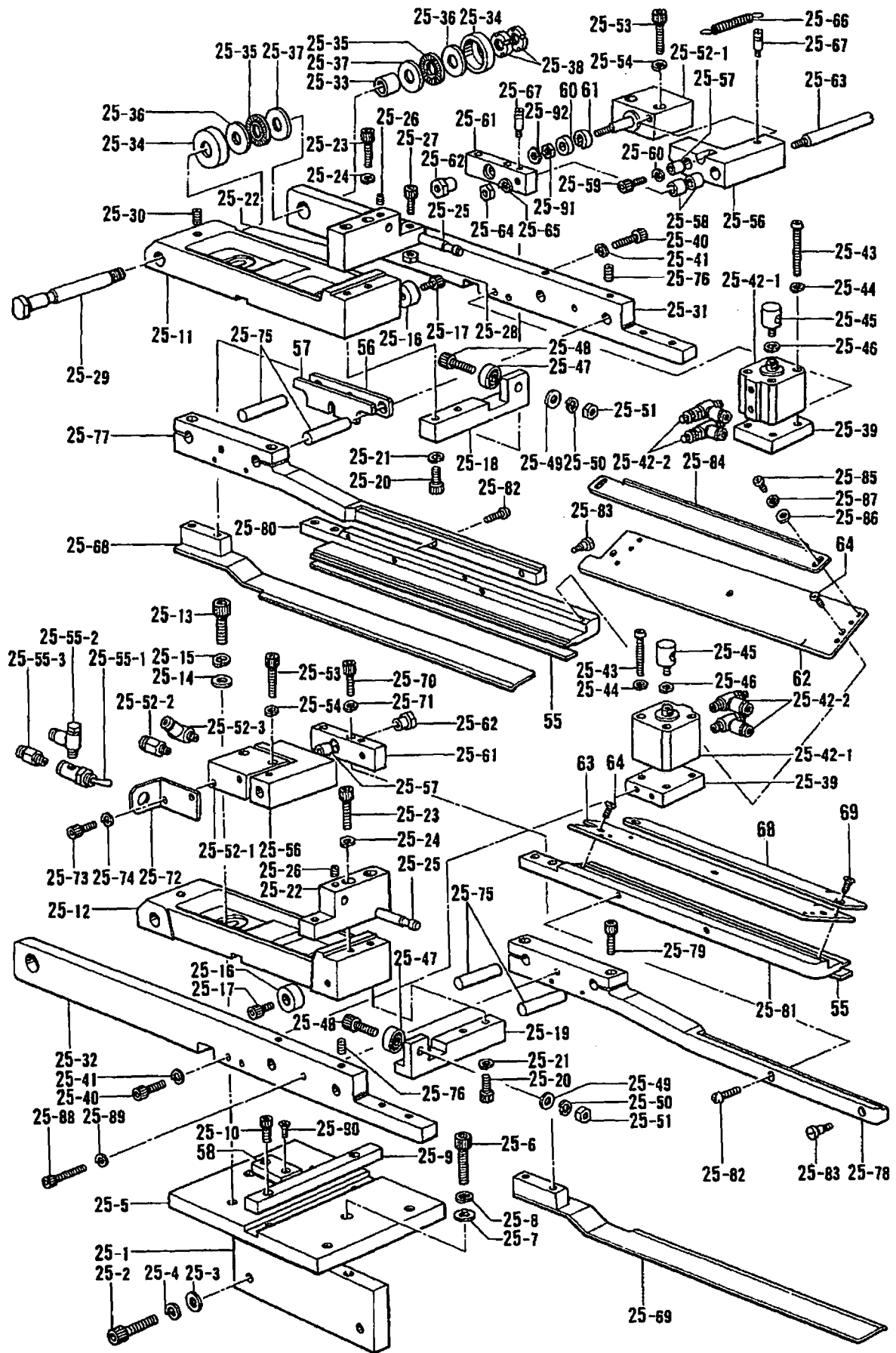

T. 布制御関係 / Cloth control system mechanism / Stoffführungsvorrichtung /  
 Mécanisme de la système de contrôle du tissu / Mecanismo de la sistema de control de tela

REF.NO.	CODE	Q'TY	ヒンメイ	NAME OF PARTS	RMKS
25-55	S08493000	2	キリカエバルブクミ	SERECTOR VALVE ASSEMBLY	
25-55-1	S08489000	2	シユトウバルブ	HAND VALVE	
25-55-2	S06883000	2	SILボム5-4	S-ELBOW M5-4	
25-55-3	S06882000	2	ツキテM5-4	JOINT M5-4	
25-56	S08253000	2	ガイドシクブラケット	GUIDE SHAFT BRACKET	
25-57	S08507000	2	ドライヘアリング	DRY BEARING	
25-58	S08397000	4	ドライヘアリング	DRY BEARING	
25-59	018401222	4	アナボルト4X12	BOLT 4X12	
25-60	028040242	4	ハネザカネチユウ4	SPRING WASHER 2-4	
25-61	S08207001	2	シリンダレンケツイタ	CYLINDER CONNECTING PLATE	
25-62	S08149001	2	ナツト	NUT	
25-63	S08256001	2	ガイドシク	GUIDE SHAFT	
25-64	021060206	2	ナツト2シユ6	NUT 6	
25-65	028060242	2	ハネザカネ 2-6	SPRING WASHER 2-6	
25-66	S08216001	2	ヒツハリハネ	SPRING	
25-67	S08509001	4	ハネカク	SPRING HOOK	
25-68	S08254001	1	オリコミイタR	FOLDING PLATE (RIGHT)	
25-69	S08255001	1	オリコミイタL	FOLDING PLATE (LEFT)	
25-70	018401622	4	アナボルト4X16	BOLT 4X16	
25-71	028040242	4	ハネザカネチユウ4	SPRING WASHER 2-4	
25-72	S08148001	2	バルブササエ	VALVE SUPPORTER	
25-73	018400822	4	アナボルト4X8	BOLT 4X8	
25-74	028040242	4	ハネザカネチユウ4	SPRING WASHER 2-4	
25-75	S08257001	4	ガイドシク	GUIDE SHAFT	
25-76	014501222	4	アナトメネシ5X12ヒラ	SCREW 5X12	
25-77	S08258101	1	オオオサエトリツケイタR	CARRIAGE FEED FITTING PLATE (RIGHT)	
25-78	S08259101	1	オオオサエトリツケイタL	CARRIAGE FEED FITTING PLATE (LEFT)	
25-79	018501622	4	アナボルト5X16	BOLT 5X16	
25-80	S08260001	1	オオオサイR	CARRIAGE FEED (RIGHT)	
25-81	S08261001	1	オオオサイL	CARRIAGE FEED (LEFT)	
25-82	062712012	2	ナヘコ476-32X20	SCREW 476X20	
25-83	110233001	2	ダンネシ4.76	STUD SCREW 4.76	
25-84	S08264001	2	キシカイト	CLOTH GUIDE	
25-85	062300416	4	ナヘコM3X4	SCREW M3X4	
25-86	025030233	4	ヒラサカネチユウ3	PLAIN WASHER 3	
25-87	028030243	4	ハネザカネ2-3	SPRING WASHER 2-3	
25-88	018504032	2	アナボルト 5X40	BOLT 5X40	
25-89	028050242	2	ハネザカネ2-5	SPRING WASHER 2-5	
25-90	004401003	2	サラネシ4X10	SCREW 4X10	
25-91	S13084001	2	ナツト	NUT	
25-92	025050232	2	ヒラサカネチユウ5	WASHER 5	
55	*	2	オオオサイゴム	CARRIAGE FEED RUBER	
56	*	2	スヘーサS	SPACER (S)	
57	*	2	スヘーサW	SPACER (W)	
58	*	1	イトウクイスヘーサ	MOVABLE BASE SPACER	
60	*	2	スヘーサS	SPACER (S)	
61	*	2	スヘーサW	SPACER (W)	
62	S08262001	1	オオオサイU-R	CARRIAGE FEED U-R	
63	S08263001	1	オオオサイU-L	CARRIAGE FEED U-L	
64	004300513	6	サラネシ3X5	SCREW 3X5	
68	S11520001	1	オリコミイタサイ	FOLDING PLATE PRESSER	*
69	004300513	2	サラネシ3X5	SCREW 3X5	*

T. 布制御関係/Cloth control system mechanism/Stoffführungsvorrichtung/  
 Mécanisme de la système de contrôle du tissu/Mecanismo de la sistema de control de tela

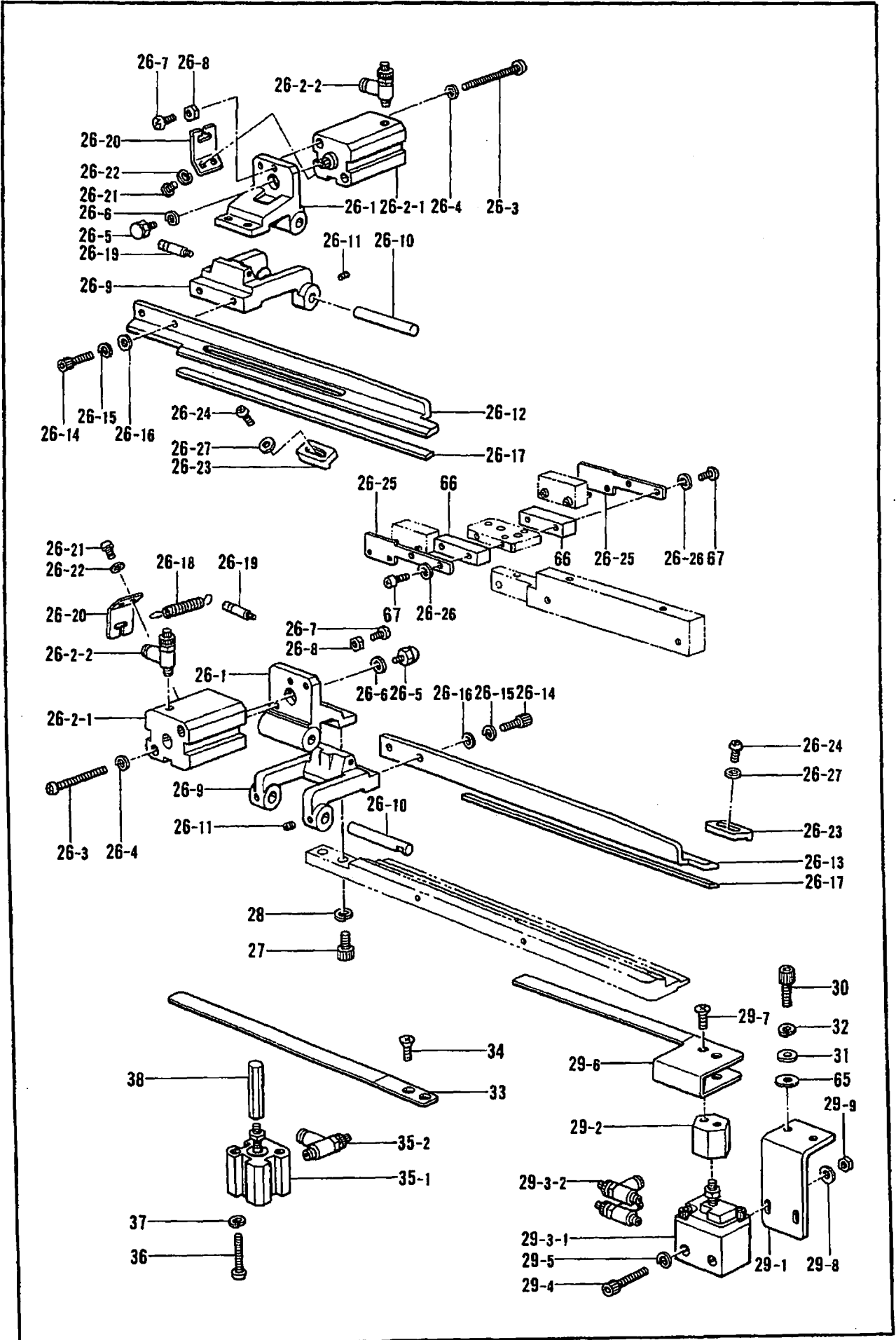

T. 布制御関係/Cloth control system mechanism/Stoffführungsvorrichtung/  
 Mécanisme de la système de contrôle du tissu/Mecanismo de la sistema de control de tela

REF.NO.	CODE	Q'TY	ヒンメイ	NAME OF PARTS	RMKS
26	S08281001	1	フラップオサエクミ	FLAP PRESSER ASSEMBLY	
26-1	S08268001	2	レハ"ー"ダイ	LEVER BRACKET	
26-2	S08271000	2	シリンタ"クミ	CYLINDER ASSEMBLY	
26-2-1	S08272000	2	シリンタ"16X20	CYLINDER 16X20	
26-2-2	S06890000	2	スピ"コンツキ"テム5-4	SPEED CONTROLLER JOINT M5-4	
26-3	S10551001	4	ナナ"ネシ"3X55	SCREW 3X55	
26-4	028030243	4	ハ"ネサ"カ"ネ2-3	SPRING WASHER 2-3	
26-5	S08273001	2	フツツヤ	PUSHER	
26-6	028030243	2	ハ"ネサ"カ"ネ2-3	SPRING WASHER 2-3	
26-7	062400816	2	ナハ"コ4X8	SCREW 4X8	
26-8	021400202	2	2シユナツト4	NUT 4	
26-9	S08275001	2	フラップオサエレハ"ー	FLAP PRESSER LEVER	
26-10	S08276001	2	シテンシ"ク	FULCRUM SHAFT	
26-11	014400522	4	アナクホ"ミ4X5	SCREW 4X5	
26-12	S08277001	1	フラップオサエR	FLAP PRESSER (RIGHT)	
26-13	S08278001	1	フラップオサエL	FLAP PRESSOR (LEFT)	
26-14	018401422	4	アナホ"ルト4X14	BOLT 4X14	
26-15	028040242	4	ハ"ネサ"カ"ネチユウ4	SPRING WASHER 2-4	
26-16	025040132	4	ヒラサ"カ"ネシヨウ4	PLAIN WASHER 4	
26-17	S08279000	2	フラップオサエゴム	FLAP PRESSER RUBBER	
26-18	S03557001	2	スライダ"ー"ヒキハ"ネ	SLIDER COIL SPRING	
26-19	S08509001	2	ハ"ネカク	SPRING HOOK	
26-20	S09446001	2	ハ"ネカクB	SPRING HOOK (B)	
26-21	062300512	4	ナハ"コ3X5	SCREW 3X5	
26-22	028030243	4	ハ"ネサ"カ"ネ2-3	SPRING WASHER 2-3	
26-23	S08266001	2	フラップ"ストツハ"	FLAP STOPPER	
26-24	062300416	2	ナハ"コM3X4	SCREW M3X4	
26-25	S08337001	2	センサ"ダイ	SENSOR BASE	
26-26	028030243	4	ハ"ネサ"カ"ネ2-3	SPRING WASHER 2-3	
26-27	025030133	2	ヒラサ"カ"ネシヨウ3	PLAIN WASHER 3	
27	018500822	4	アナホ"ルト5X8	BOLT 5X8	
28	028050242	4	ハ"ネサ"カ"ネ2-5	SPRING WASHER 2-5	
29	S09447001	1	シンシ"オサエクミ	FUSING PAPER PRESSER FOOT ASSEMBLY	
29-1	S08211001	1	シリンタ"トリツケイタ	CYLINDER FITTING PLATE	
29-2	S08213001	1	ハ"ネトリツケシ"ク	SPRING FITTING SHAFT	
29-3	S08499000	1	シリンタ"クミ	CYLINDER ASSEMBLY	
29-3-1	S08243000	1	シリンタ"16X10	CYLINDER 16X10	
29-3-2	S08498000	2	スピ"コンツキ"テム5-4	SPEED CONTROLLER JOINT M5-4	
29-4	018402522	2	アナホ"ルト4X25	BOLT 4X25	
29-5	028040242	4	ハ"ネサ"カ"ネチユウ4	SPRING WASHER 2-4	
29-6	S08215001	1	シンシ"オサエハ"ネR	SPRING (RIGHT)	
29-7	004300513	2	+ サラネシ"3X5	SCREW 3X5	
29-8	025040232	2	ヒラサ"カ"ネチユウ4	PLAIN WASHER 4	
29-9	021400202	2	2シユナツト4	NUT 2-4	
30	018502022	2	アナホ"ルト5X20	BOLT 5X20	
31	025050232	2	ヒラサ"カ"ネチユウ-5	PLAIN WASHER 5	
32	028050242	2	ハ"ネサ"カ"ネ2-5	SPRING WASHER 2-5	
33	S08214001	1	シンシ"オサエハ"ネL	SPRING (LEFT)	
34	004401003	2	+ サラネシ"4X10	SCREW 4X10	
35	S09174000	1	シリンタ"クミ	CYLINDER ASSEMBLY	
35-1	S09175000	1	シリンタ"10X5	CYLINDER 10X5	
35-2	S06890000	1	スピ"コンツキ"テム5-4	SPEED CONTROLLER JOINT M5-4	
36	062302506	2	ナハ"コ3X25	SCREW 3X25	
37	028030243	2	ハ"ネサ"カ"ネ2-3	SPRING WASHER 2-3	
38	S08208001	1	シンシ"フツツヤ	SHAFT	
65	025060336	2	ヒラサ"カ"ネタ"16	PLAIN WASHER 6	
66	*	2	フラップ"スハ"ー"サ	FLAP SPACER	
67	*	4	ナハ"コ	SCREW	

U. 踏板関係/Treadle mechanism/Fubbetätigung/  
Mécánisme de la pédale/Mecanismo del pedal

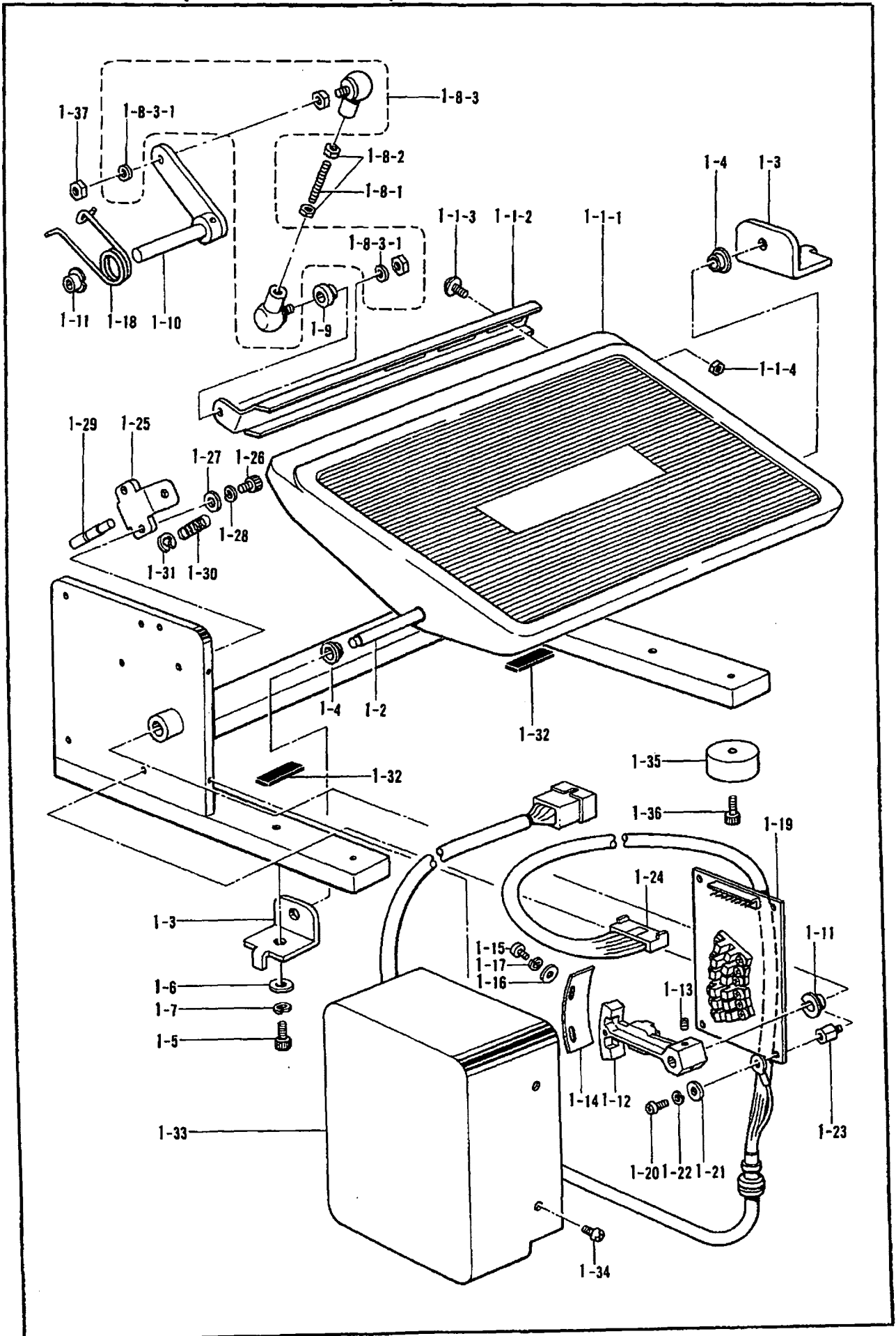

U. 踏板関係/Treadle mechanism/Fubbetätigung/  
Mécánisme de la pédale/Mecanismo del pedal

REF.NO.	CODE	QTY	ヒンメイ	NAME OF PARTS	RMKS
1	S08409001	1	フットスイッチクミ	FOOT SWITCH ASSEMBLY	
1-1-1	183387001	1	フミイタ クミ	TREADLE ASSEMBLY	
1-1-2	119709002	1	レンカントリツケウテ	CONNECTING ROD SETTING ARM	
1-1-3	S06694001	2	ナヘ"コヒラサ"6X16	SCREW 6X16	
1-1-4	021060106	2	ナツト1シユ6	NUT 6	
1-2	119706001	1	フミイタシ"ク	TREADLE SHAFT	
1-3	119707002	2	フミイタシ"クウケ	TREADLE SHAFT BRACKET	
1-4	119708001	2	フミイタシ"クウケカラ-	TREADLE SHAFT BRACKET COLLAR	
1-5	018082022	2	アナホ"ルト8X20	BOLT 8X20	
1-6	025080232	2	ヒラサ"ガ"ネチユウ8	PLAIN WASHER 8	
1-7	028080242	2	ハ"ネサ"ガ"ネ2-8	SPRING WASHER 2-8	
1-8	S08411001	1	レンカクミ	CONNECTING ROD ASSEMBLY	
1-8-1	S08412001	1	レンカン	CONNECTING ROD	
1-8-2	021060106	2	ナツト1シユ6	NUT 6	
1-8-3	133792101	2	シ"ヨイントクミ	JOINT ASSEMBLY	
1-8-3-1	028080243	2	ハ"ネサ"ガ"ネ2-6	SPRING WASHER 2-6	
1-9	114859001	1	レンカンカラ-	CONNECTING ROD COLLAR	
1-10	S08413001	1	フットスイッチレハ"ークミ	FOOT SWITCH LEVER ASSEMBLY	
1-11	S08416000	2	ト"ライハ"アリンク"	DRY BEARING	
1-12	S08417000	1	アーム	ARM	
1-13	014400822	2	アナトメネシ"4クホ"ミ	SET SCREW 4	
1-14	S08418000	1	ホトカフ"ラト"ウサイタ	PHOTO COUPLER ACTUATE PLATE	
1-15	062400806	2	ナヘ"コ4X8	SCREW 4X8	
1-16	025040233	2	ヒラサ"ガ"ネチユウ4	PLAIN WASHER 4	
1-17	028040243	2	ハ"ネサ"ガ"ネ2-4	SPRING WASHER 2-4	
1-18	S08419001	1	フットスイッチハ"ネ	FOOT SWITCH SPRING	
1-19	S08420000	1	キハ"ンクミB439013クミ	CIRCUIT BOARD (B439013) ASSEMBLY	
1-20	062400806	4	ナヘ"コ4X8	SCREW 4X8	
1-21	025040233	4	ヒラサ"ガ"ネチユウ4	PLAIN WASHER 4	
1-22	028040243	4	ハ"ネサ"ガ"ネ2-4	SPRING WASHER 2-4	
1-23	S08421000	4	スヘ"ーサ	SPACER	
1-24	S08422000	1	FSWハ"ーネスクミ	FOOT SWITCH HARNESS ASSEMBLY	
1-25	S08423001	1	フミカエシシ"クウケ	INDICATION SHAFT SUPPORTER	
1-26	018401222	2	アナホ"ルト4X12	BOLT 4X12	
1-27	025040232	2	ヒラサ"ガ"ネチユウ4	PLAIN WASHER 4	
1-28	028040242	2	ハ"ネサ"ガ"ネチユウ4	SPRING WASHER 2-4	
1-29	S08424001	1	フミカエシシ"ク	INDICATION SHAFT	
1-30	147843001	1	ラツクモト"シハ"ネ	RACK RETURN SPRING	
1-31	048060342	1	トメ"フE6	STOP RING E6	
1-32	S14197000	2	クツシヨ"ン C	CUSHION (C)	
1-33	S08426001	1	フットスイッチカハ"ー	FOOT SWITCH COVER	
1-34	008400804	4	+トラスコ4X6	SCREW 4X6	
1-35	S01830000	4	ハ"ネルカハ"ーアシ	COVER LEG	
1-36	018401622	4	アナホ"ルト4X16	BOLT 4X16	
1-37	021060106	1	ナツト1シユ6	NUT 6	

V. 動力台関係/Power table/Motorgestell/  
 Mécanisme du plateau de la machine/Mecanismo de la mesa de la máquina

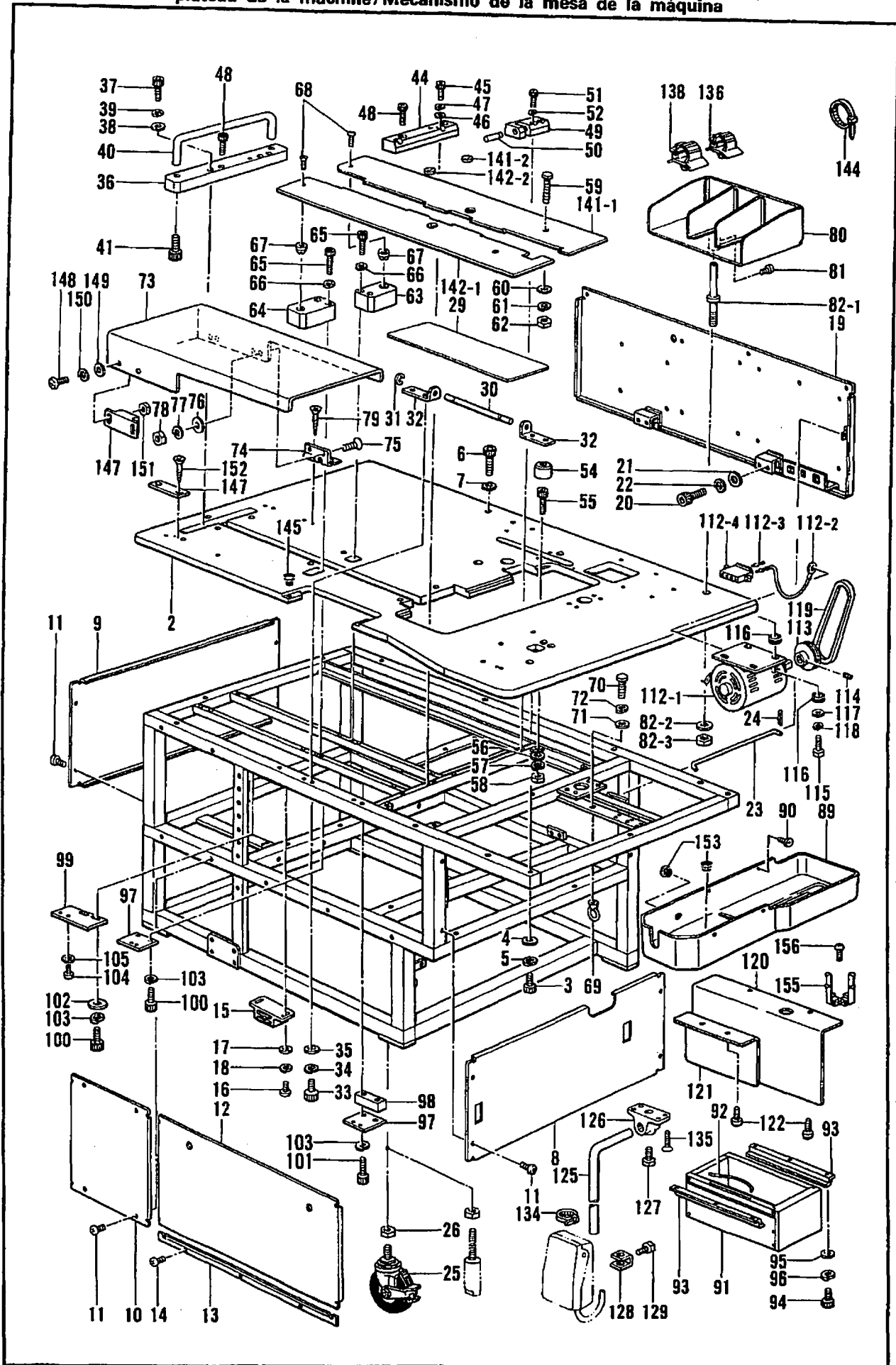

V. 動力台関係/Power table/Motorgestell/  
Mécanisme du plateau de la machine/Mecanismo de la mesa de la máquina

REF.NO.	CODE	Q'TY	ヒンメイ	NAME OF PARTS	RMKS
2	S14795001	1	BAS610テーブル	BAS 610 TABLE	
3	018501422	7	アナボルト5X14	BOLT 5X14	
4	025050232	7	ヒラサ"カ"ネチユウ5	PLAIN WASHER 5	
5	028050242	7	ハ"ネサ"カ"ネ2-5	SPRING WASHER 2-5	
6	018401622	11	アナボルト4X16	BOLT 4X16	
7	025040232	11	ヒラサ"カ"ネチユウ4	PLAIN WASHER 4	
8	S15601001	1	マエカバー	FRONT COVER	
9	S08185001	1	ウシロカバー	REAR COVER	
10	S08186001	1	ヒタ"リRカバー	LEFT (REAR) COVER	
11	008400604	12	+トラスコ4X6	SCREW 4X6	
12	S08187001	1	ヒタ"リFカバー	LEFT (FRONT) COVER	
13	S08193001	1	カバーウケ	COVER SUPPORTER	
14	008400604	3	+トラスコ4X6	SCREW 4X6	
15	S09448000	2	マグネット	MAGNET	
16	062300616	4	ナヘ"コM3X6	SCREW M3X6	
17	025030233	4	ヒラサ"カ"ネチユウ3	PLAIN WASHER 3	
18	028030243	4	ハ"ネサ"カ"ネ2-3	SPRING WASHER 2-3	
19	S08189001	1	ミキ"カバー	RIGHT COVER	
20	018501222	4	アナボルト5X12	BOLT 5X12	
21	025050232	4	ヒラサ"カ"ネチユウ5	PLAIN WASHER 5	
22	028050242	4	ハ"ネサ"カ"ネ2-5	SPRING WASHER 2-5	
23	S08191001	1	トヒ"ラステー	DOOR STAY	
24	114909000	1	フリヒン	SPLIT PIN	
25	S00403000	4	キャスター	CASTER	
26	021200203	4	ナット2シユ20	NUT 20	
29	S08194001	1	ホシ"ヨテーブル	SUB TABLE	
30	S08368001	1	ホシ"ヨテーブルヨウシク	SHAFT	
31	048050342	2	トメフE5	STOP RING E5	
32	S08270001	2	ホシ"ヨテーブルウケ	SUB TABLE SUPPORTER	
33	018500822	4	アナボルト5X8	BOLT 5X8	
34	028050242	4	ハ"ネサ"カ"ネ2-5	SPRING WASHER 2-5	
35	025050232	4	ヒラサ"カ"ネチユウ5	PLAIN WASHER 5	
36	S08283001	1	トリツケタ"イウシロ	SETTING BASE REAR	
37	018062022	2	アナボルト6X20	BOLT 6X20	
38	025060232	2	ヒラサ"カ"ネチユウ 6	PLAIN WASHER 6	
39	028060242	2	ハ"ネサ"カ"ネ 2-6	SPRING WASHER 2-6	
40	S08190001	1	オオオサエウケ	CARRIAGE FEED SUPPORTER	
41	018082022	2	アナボルト8X20	BOLT 8X20	
44	S14796001	1	トリツケタ"イマエ	SETTING BASE FRONT	
45	018062022	2	アナボルト6X20	BOLT 6X20	
46	025060232	2	ヒラサ"カ"ネチユウ 6	PLAIN WASHER 6	
47	028060242	2	ハ"ネサ"カ"ネ 2-6	SPRING WASHER 2-6	
48	018082522	4	アナボルト8X25	BOLT 8X25	
49	S14797001	2	ヒンジウケ	HINGE SUPPORTER	
50	S14798001	2	ローレットピン	KNURL PIN	
51	018401622	4	アナボルト4X16	BOLT 4X16	
52	028040242	4	ハ"ネサ"カ"ネチユウ4	SPRING WASHER 2-4	
54	S08205000	4	クッション	CUSHION	
55	018061622	4	アナボルト6X16	BOLT 6X16	
56	025060232	4	ヒラサ"カ"ネチユウ 6	PLAIN WASHER 6	
57	028060242	4	ハ"ネサ"カ"ネ 2-6	SPRING WASHER 2-6	
58	021060102	4	ナット1シユ6	NUT 6	
59	S08200001	2	イチキメボルト	POSITIONING BOLT	
60	025060232	2	ヒラサ"カ"ネチユウ 6	PLAIN WASHER 6	
61	028060242	2	ハ"ネサ"カ"ネ 2-6	SPRING WASHER 2-6	
62	021060102	2	ナット1シユ6	NUT 6	
63	S09449001	1	シデンピンアンナイR	GUIDE (RIGHT)	
64	S08201001	1	シデンピンアンナイL	GUIDE (LEFT)	
65	018401622	4	アナボルト4X16	BOLT 4X16	
66	028040242	4	ハ"ネサ"カ"ネチユウ4	SPRING WASHER 2-4	
67	S08197001	2	シデンピン	PIN	
68	004300602	2	フラスサラネシ"3X6	SCREW 3X6	



V. 動力台関係/Power table/Motorgestell/  
 Mécanisme du plateau de la machine/Mecanismo de la mesa de la máquina

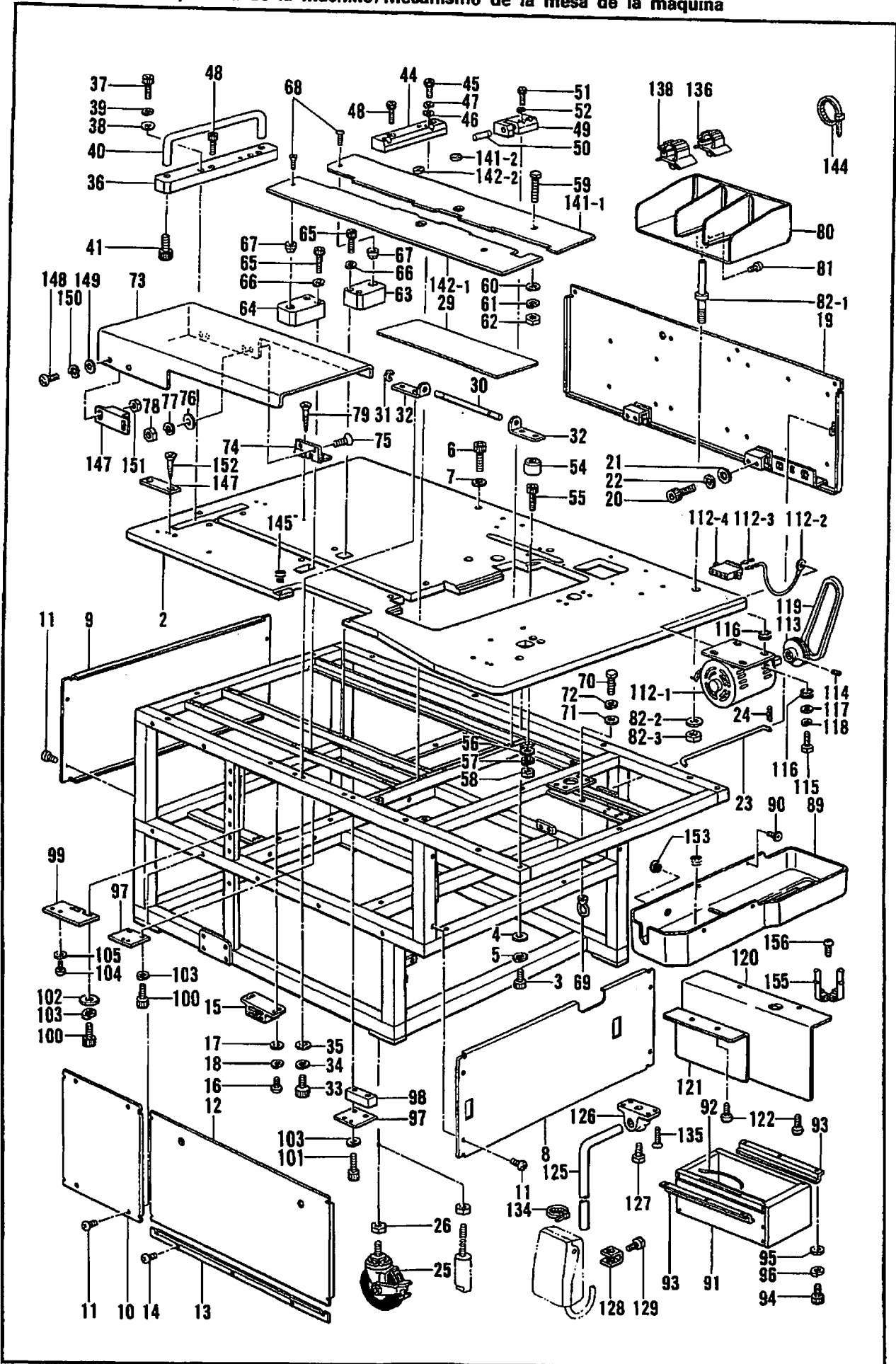

V. 動力台関係/Power table/Motorgestell/  
Mécánisme du plateau de la machine/Mecanismo de la mesa de la máquina

REF.NO.	CODE	QTY	品名	NAME OF PARTS	RMKS
69	S07026001	1	エアガンフック	AIR GAN HOOK	
70	017082203	1	ボルト8X22	BOLT 8X22	
71	025080232	1	ヒラサガネチユウ8	PLAIN WASHER 8	
72	028080242	1	ハネサガネ2-8	SPRING WASHER 2-8	
73	S08206002	1	トップカバー	TOP COVER	
74	S09690001	2	チヨウハン	HINGE	
75	004301003	4	+サラネシ3X10	SCREW 3X10	
76	025030232	4	ヒラサガネチユウ3	PLAIN WASHER 3	
77	028030242	4	ハネサガネ2-3	SPRING WASHER 2-3	
78	021300103	4	ナット1シユ3	NUT 3	
79	034311302	4	サラモクネシ3.1X13	SCREW 3.1X13	
80	S08221001	1	ヌノウケサラ	CLOTH SUPPORT DISC	
81	062060806	2	ナヘコ6X8	SCREW 6X8	
82	S10559001	1	ヌノウケサラシチユウクミ	DISC STUD ASSEMBLY	
82-1	S08222001	1	ヌノウケサラシチユウ	DISC STUD	
82-2	150206002	1	ヒラサガネ16	PLAIN WASHER 16	
82-3	150191001	1	ロツカクナットU5/8	NUT 5/8"	
89	S15673001	1	オイルパン	OIL PAN	
90	008300604	4	+トラスコ3X6	SCREW 3X6	
91	S08192001	1	ヒキダシ	DRAWER	
92	101073001	1	ヒキダシコテイハネ	SPRING	
93	S08427001	2	ヒキダシササエ	DRAWER SUPPORTER	
94	018300822	6	アナボルト3X8	BOLT 3X8	
95	025030232	6	ヒラサガネチユウ3	PLAIN WASHER 3	
96	028030242	6	ハネサガネ2-3	SPRING WASHER 2-3	
97	S08224001	2	センサートリツケタイ	SESOR SETTING BASE	
98	S08225001	1	スパーサ	SPACER	
99	S09450001	1	センサートリツケタイL	SENSOR SETTING BASE (LARGE)	
100	018401222	4	アナボルト4X12	BOLT 4X12	
101	018402522	2	アナボルト4X25	BOLT 4X25	
102	025040232	6	ヒラサガネチユウ4	PLAIN WASHER 4	
103	028040242	6	ハネサガネ2-4	SPRING WASHER 2-4	
104	002301203	6	+ナヘネシ3X12	SCREW 3X12	
105	025030233	6	ヒラサガネチユウ3	PLAIN WASHER 3	
112	S08089001	1	3ソウモータ200Vクミ	THREE PHASE MOTOR 200V ASSEMBLY	
112-1	159812001	1	モータ	MOTOR	
112-2	S00614000	1	モータアースセン	EARTH WIRE	
112-3	143549000	3	ピンターミナルオス	TERMINAL PIN (MALE)	
112-4	S00603000	1	コネクタ4P	4P CONNECTOR	
113	159386001	1	モータプーリ3200/60	MOTOR PULLEY 3200/60	
114	151605002	2	トメネシ5.95	SET SCREW 5.95	
115	017062503	4	6カクボルト6X25	BOLT 6X25	
116	S00617000	8	ホウシンゴムカラー	RUBBER COLLAR	
117	025060336	4	ヒラサガネタイ6	PLAIN WASHER 6	
118	028060242	4	ハネサガネ2-6	SPRING WASHER 2-6	
119	082104190	1	Vベルト41	V BELT M41	
120	S15067001	1	ベルトカバー-R	BELT COVER (RIGHT)	
121	S16255001	1	モータカバー	MOTOR COVER	
122	008400604	4	+トラスコ4X6	SCREW 4X6	
125	S08220001	1	ヒサスイツチタテジク	KNEE SWITCH VERTICAL SHAFT	
126	142027001	1	ヒサスイツチタテジクウケ	KNEE SWITCH SHAFT BRACKET	
127	100463001	1	4カクボルト7.94	BOLT 7.94	
128	114967001	1	ヒサアテストツパ	KNEE LIFTER PLATE STOPPER	
129	110087001	1	ボルト5.95	BOLT 5.95	
134	S04557000	1	ハンタイPLTIM	BAND PLTIM	
135	004401003	4	+サラネシ4X10	SCREW 4X10	
136	150349001	4	コートクランプ10	CORD CLAMP (10)	
138	S09142000	10	コートクランプ20L	CORD CLAMP (20L)	

V. 動力台関係/Power table/Motorgestell/  
 Mécanisme du plateau de la machine/Mecanismo de la mesa de la máquina

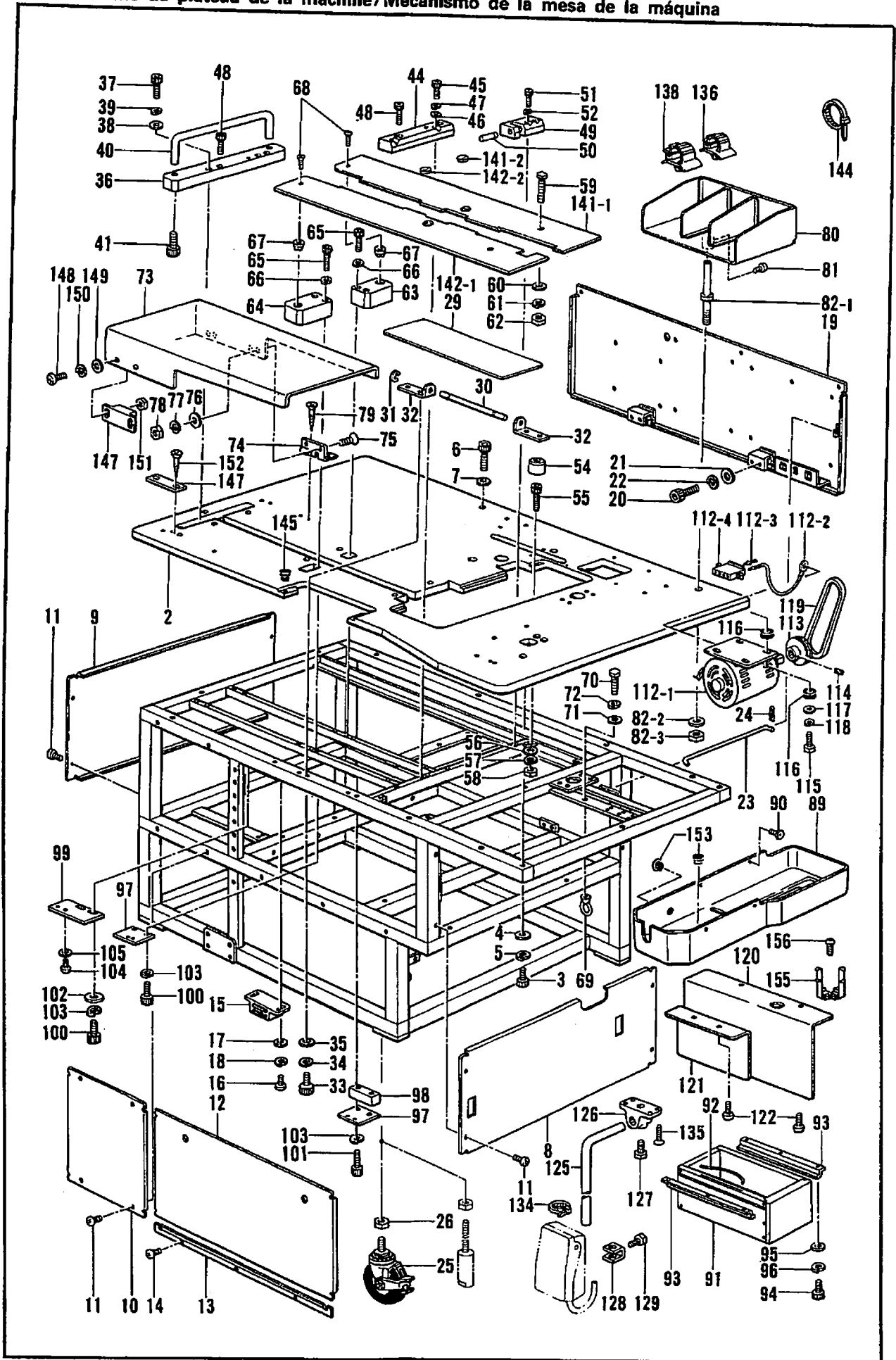

V. 動力台関係/Power table/Motorgestell/  
 Mécanisme du plateau de la machine/Mecanismo de la mesa de la máquina

REF.NO.	CODE	Q'TY	ヒンメイ	NAME OF PARTS	RMKS
141	*	1	キジスベ"リイタRクミ	SLIDE PLATE (RIGHT) ASSEMBLY	
141-1	S08196001	1	キジスベ"リイタR (8-12MM)	SLIDE PLATE (RIGHT) (8-12MM)	
141-1	S08196002	1	キジスベ"リイタR (14-16MM)	SLIDE PLATE (RIGHT) (14-16MM)	
141-1	S08196003	1	キジスベ"リイタR (18-20MM)	SLIDE PLATE (RIGHT) (18-20MM)	
141-2	S07320000	1	スベ"リイタマト"	BOBBIN WINDOW	
142	*	1	キジスベ"リイタLクミ	SLIDE PLATE (LEFT) ASSEMBLY	
142-1	S08199001	1	キジスベ"リイタL (8-12MM)	SLIDE PLATE (LEFT) (8-12MM)	
142-1	S08199002	1	キジスベ"リイタL (14-16MM)	SLIDE PLATE (LEFT) (14-16MM)	
142-1	S08199003	1	キジスベ"リイタL (18-20MM)	SLIDE PLATE (LEFT) (18-20MM)	
142-2	S07320000	1	スベ"リイタマト"	BOBBIN WINDOW	
144	149809000	1	タイラツツ" L	BEAD BAND (LARGE)	
145	104821001	4	メクラゼン	OIL CAP	
147	S09448000	1	マグネット	MAGNET	
148	062300616	2	ナベ"コM3X6	SCREW M3X6	
149	025030233	2	ヒラサ"カ"ネチユウ3	PLAIN WASHER 3	
150	028030243	2	ハ"ネサ"カ"ネ2-3	SPRING WASHER 2-3	
151	021300103	2	ナット1 シユ3	NUT 3	
152	034311302	2	サラモクネシ"3.1X13	SCREW 3.1X13	
153	150756000	2	メクラゼン	OIL CAP	
155	133172003	1	アブラサシタ"イ	OILER BASE	
156	008400604	1	+トラスコ4X6	SCREW 4X6	

W. ゲージ部品関係/Gauge parts assembly/Lehrenteile/  
 Ensemble des pièces calibrées/Conjunto de piezas calibradoras

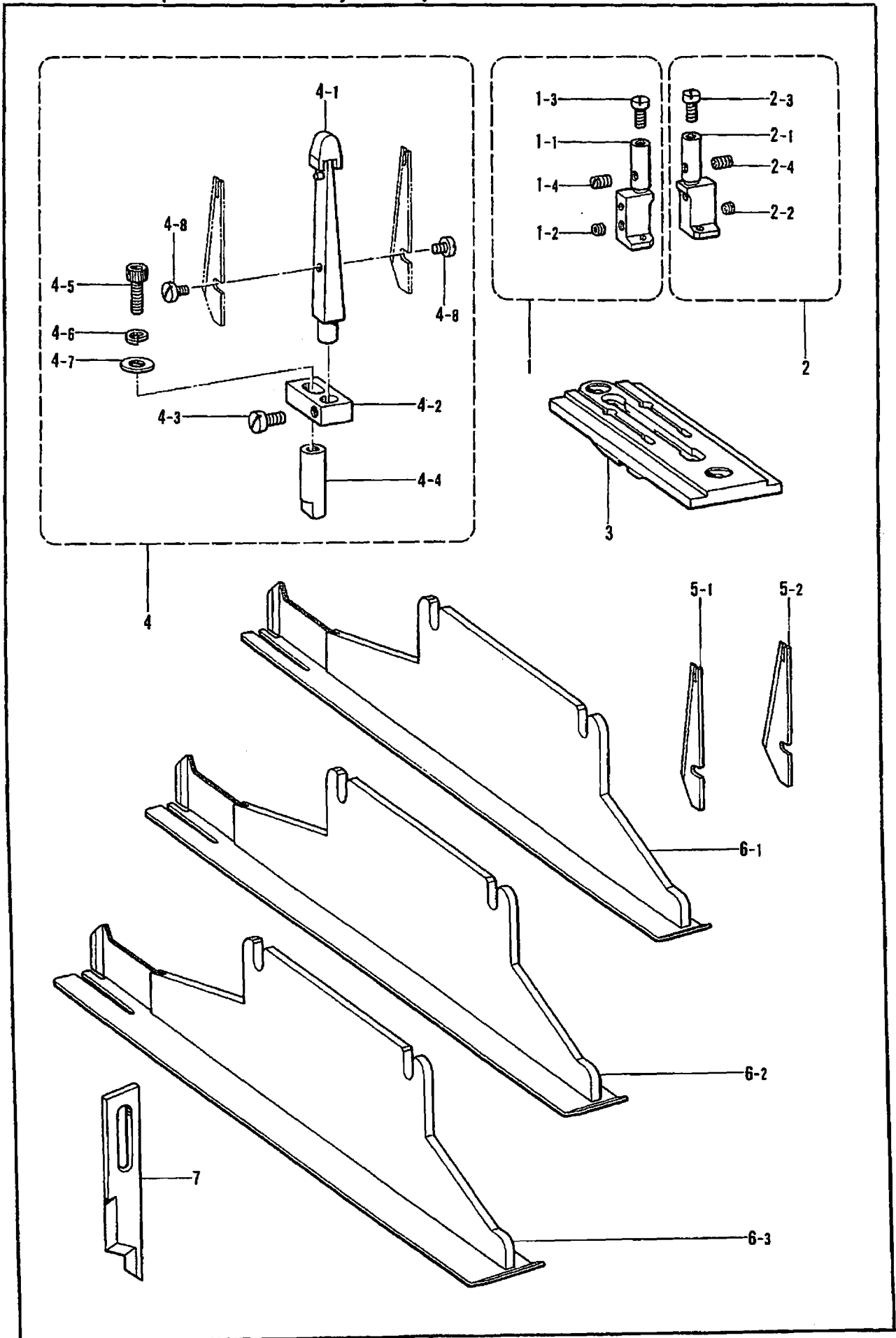

W. ゲージ部品関係 / Gauge parts assembly / Lehrenteile /  
 Ensemble des pièces calibrées / Conjunto de piezas calibradoras

REF.NO.	CODE	Q'TY	ヒンメイ	NAME OF PARTS	RMKS
1	*	1	ハリタ <sup>ク</sup> セットL	NEEDLE CLAMP SET (LEFT)	
1-1	*	1	ハリタ <sup>ク</sup> クミL	NEEDLE CLAMP ASSEMBLY (LEFT)	
1-2	146427001	1	アナトメネジ <sup>ク</sup> 3.18クホ <sup>ク</sup> ミ	SET SCREW 3.18	
1-3	149831101	1	アタマツキトメネジ <sup>ク</sup> 3.18	SET SCREW 3.18	
1-4	S13085001	1	トメネジ <sup>ク</sup> 3.18	SET SCREW 3.18	
2	*	1	ハリタ <sup>ク</sup> セットR	NEEDLE CLAMP SET (RIGHT)	
2-1	*	1	ハリタ <sup>ク</sup> クミR	NEEDLE CLAMP ASSEMBLY (RIGHT)	
2-2	146427001	1	アナトメネジ <sup>ク</sup> 3.18クホ <sup>ク</sup> ミ	SET SCREW 3.18	
2-3	149831101	1	アタマツキトメネジ <sup>ク</sup> 3.18	SET SCREW 3.18	
2-4	S13085001	1	トメネジ <sup>ク</sup> 3.18	SET SCREW 3.18	
3	*	1	ハリイタ	NEEDLE PLATE	
4	*	1	メスタ <sup>ク</sup> イセット	KNIFE BASE SET	
4-1	*	1	メスタ <sup>ク</sup> イクミ	KNIFE BASE ASSEMBLY	
4-2	S14752001	1	メスタ <sup>ク</sup> イ	KNIFE BASE	
4-3	140553102	1	アタマツキトメネジ <sup>ク</sup> 3.18	SET SCREW 3.18	
4-4	S14753001	1	メスタ <sup>ク</sup> イシ <sup>ク</sup>	KNIFE BASE SHAFT	
4-5	018401222	1	アナボ <sup>ク</sup> ルト4X12	BOLT 4X12	
4-6	028040242	1	ハ <sup>ク</sup> ネサ <sup>ク</sup> ガ <sup>ク</sup> ネチユウ4	SPRING WASHER 2-4	
4-7	025040232	1	ヒラサ <sup>ク</sup> ガ <sup>ク</sup> ネチユウ4	PLAIN WASHER 4	
4-8	111140002	2	シメネジ <sup>ク</sup> 2.38	SCREW 2.38	
5-1	S14050001	4	セラミツクコーナーメス S (8-14MM)	CERAMIC CORNER KNIFE (SMALL) (8-14MM)	
5-2	S14051001	4	セラミツクコーナーメス L (16-20MM)	CERAMIC CORNER KNIFE (LARGE) (16-20MM)	
6-1	S15602001	1	OFシ <sup>ク</sup> ヨウキ <sup>ク</sup> クミ 10MM	OFFSET BINDER (10MM)	
6-2	S15604001	1	OFシ <sup>ク</sup> ヨウキ <sup>ク</sup> クミ 12MM	OFFSET BINDER (12MM)	
6-3	S15606001	1	OFシ <sup>ク</sup> ヨウキ <sup>ク</sup> クミ 14MM	OFFSET BINDER (14MM)	
7	S16248001	1	ウウメス B	UPPER KNIFE (B)	

X. 特別注文部品/Option part/Sonderteile/  
Pièce optionnelle/Pieza opcional

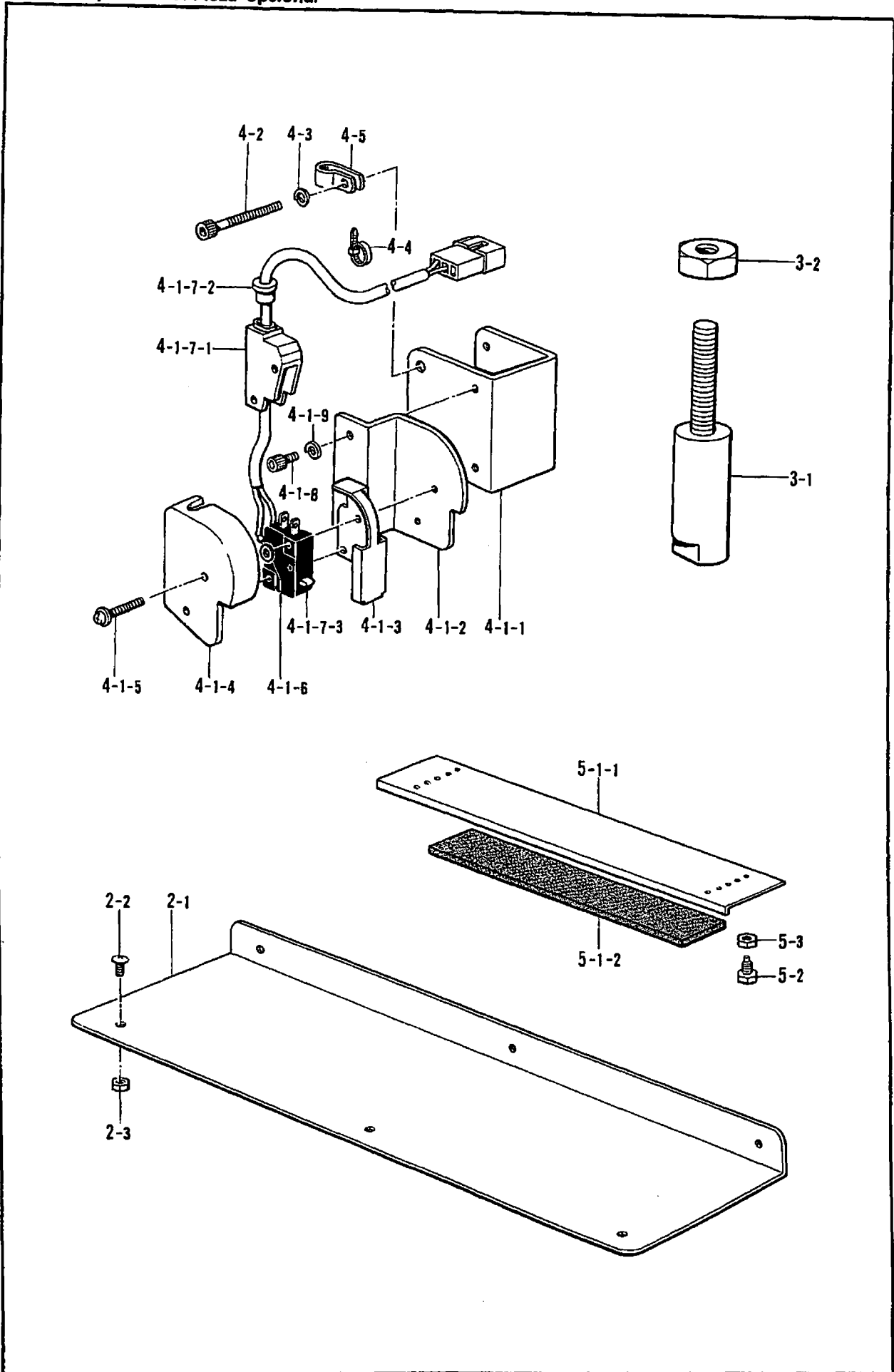

X. 特別注文部品/Option part/Sonderteile/  
Pièce optionnelle/Pieza opcional

REF.NO.	CODE	Q'TY	ヒンメイ	NAME OF PARTS	RMKS
2	S11502001	1	ホジヨタイクミ	AUXILARY ASSEMBLY	
2-1	S09687001	1	ホジヨタイ	AUXILARY	
2-2	008400604	3	トラスコ4X6	SCREW 4X6	
2-3	021400103	3	ナツト1シユ4	NUT 4	
3	S11148001	4	チヨウセツネシクミ	ADJUSTING SCREW ASSEMBLY	
3-1	S00402001	4	チヨウセツネシ	ADJUSTING SCREW	
3-2	021200203	4	ナツト2シユ20	NUT 20	
4	S11503001	1	テモトスタートスイッチクミ	HAND START SWITCH ASSEMBLY	
4-1	S11334001	1	テモトスイッチクミ	HAND SWITCH ASSEMBLY	
4-1-1	S11335001	1	スタートスイッチタイ	START SWITCH BRACKET	
4-1-2	S04607001	1	スイッチトリツケイタ	SWITCH SETTING PLATE	
4-1-3	149069101	1	アクチュエータ	ACTUATOR	
4-1-4	149070001	1	スイッチカバー	SWITCH COVER	
4-1-5	522990001	2	サツキシメネシ3X19	SCREW 3X19	
4-1-6	025030233	2	ヒラサガネチユウ3	PLAIN WASHER 3	
4-1-7	S11336001	1	スイッチクミ	SWITCH ASSEMBLY	
4-1-7-1	143531000	1	マイクロSWカバー	MICRO SWITCH COVER	
4-1-7-2	146080000	1	コードブシ	CORD BUSH	
4-1-7-3	149066001	1	マイクロスイッチ	MICRO SWITCH	
4-1-8	018400622	2	アナボルト4X6	BOLT 4X6	
4-1-9	028040242	2	ハネサガネチユウ4	SPRING WASHER 2-4	
4-2	155055001	2	アナボルト4X45	BOLT 4X45	
4-3	028040242	2	ハネサガネチユウ4	SPRING WASHER 2-4	
4-4	S04557000	2	バンドタイPLTIM	BAND PLTIM	
4-5	149547000	1	コードオサエ	CORD HOLDER	
5	S11504001	1	フラップガイドクミ	FLAP GUIDE ASSEMBLY	
5-1	S11505000	1	フラップガイド	FLAP GUIDE	
5-1-1	S11083000	1	ガイドイタ	GUIDE PLATE	
5-1-2	S11506000	1	ゴムイタシヤク	RUBBER MAGNET	
5-2	S11084001	2	フラップガイドピン	PIN	
5-3	021400103	2	ナツト1シユ4	NUT 4	



X. 特別注文部品 (ダーツノバシ) / Option part (Darts stretcher) / Sonderteile (Abnäherstrecker) /  
 Pièce optionnelle / Pieza opcional (estirador de sisa)

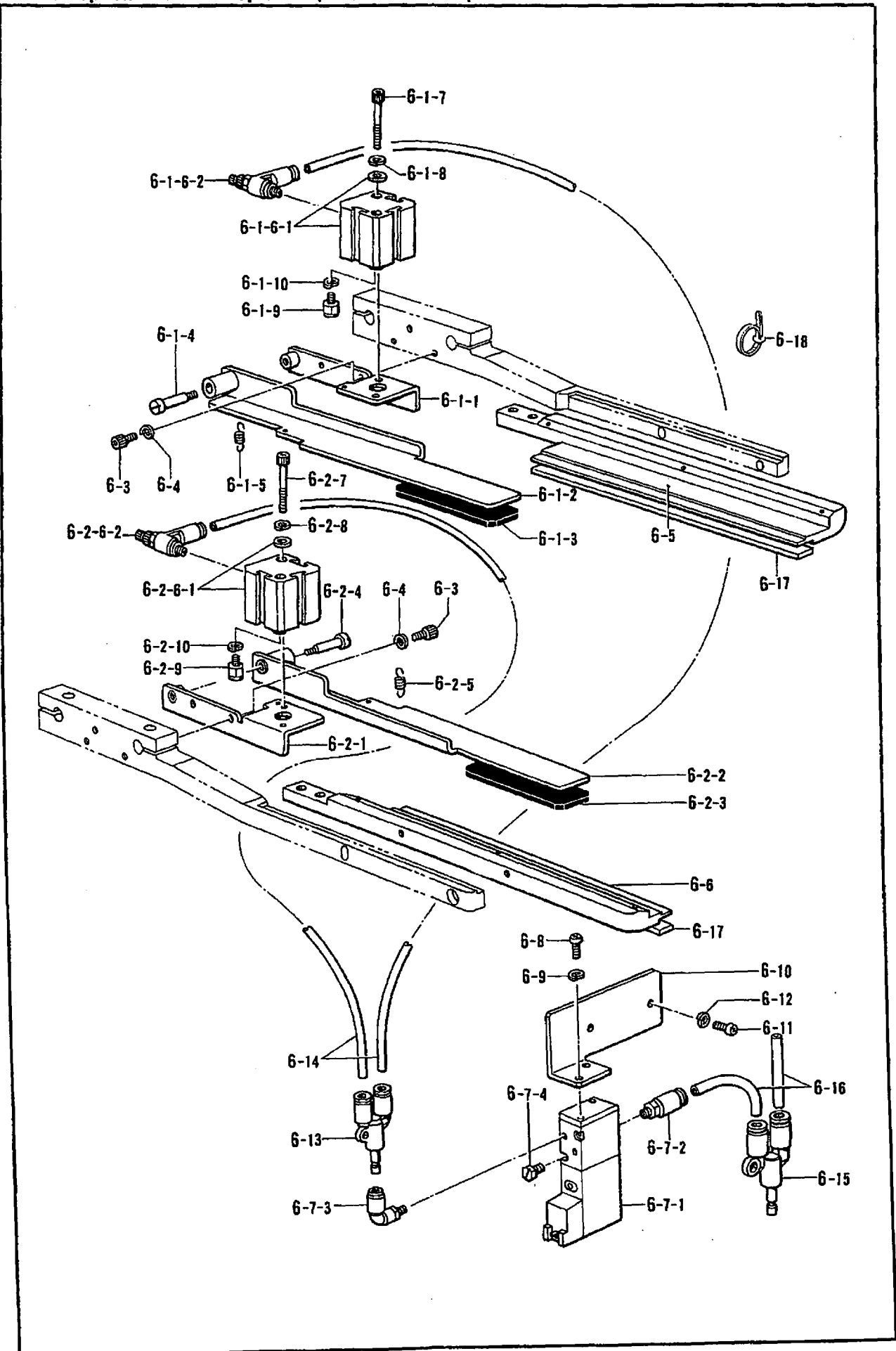

X. 特別注文部品 (ダーツノバシ)/Option part (Darts stretcher)/Sonderteile (Abnaherstrecker)/  
Pice optionnelle (tendeur pour pince)/Pieza opcional (estirador de sisa)

REF.NO.	CODE	Q'TY	ヒンメイ	NAME OF PARTS	RMKS
6	S15890001	1	ダーツノバシシクミ610	DARTS STRETCHER ASSEMBLY	
6-1	S15891001	1	ダーツオサエRクミ	DARTS PRESSER (RIGHT) ASSEMBLY	
6-1-1	S13570001	1	Dフ"ラケツトR	DARTS BRACKET (RIGHT)	
6-1-2	S13572001	1	ダーツオサエR	DARTS PRESSER (RIGHT)	
6-1-3	S13576000	1	ダーツオサエゴム	DARTS PRESSER RUBBER	
6-1-4	159732001	1	ダ"ネシ"4.37	STUD SCREW 4.37	
6-1-5	S10268001	1	イトマキウテ"ハ"ネ	THREAD WINDER ARM SPRING	
6-1-6	S13574000	1	シリンダ"クミ	CYLINDER ASSEMBLY	
6-1-6-1	S13575000	1	シリンダ"16X10	CYLINDER 16X10	
6-1-6-2	S06890000	1	スピ"コンツキ"テム5-4	SPEED CONTROLLER JOINT M5-4	
6-1-7	S12642001	2	アナホ"ルト3X35	BOLT 3X35	
6-1-8	028030243	2	ハ"ネサ"カ"ネ2-3	SPRING WASHER 2-3	
6-1-9	S04411001	1	Bクランプ"ヘッド"	(B) CLAMP HEAD	
6-1-10	028030243	1	ハ"ネサ"カ"ネ2-3	SPRING WASHER 2-3	
6-2	S15892001	1	ダーツオサエLクミ	DARTS PRESSER (LEFT) ASSEMBLY	
6-2-1	S13571001	1	Dフ"ラケツトL	DARTS BRACKET (LEFT)	
6-2-2	S13573001	1	ダーツオサエL	DARTS PRESSER (LEFT)	
6-2-3	S13576000	1	ダーツオサエゴム	DARTS PRESSER RUBBER	
6-2-4	159732001	1	ダ"ネシ"4.37	STUD SCREW 4.37	
6-2-5	S10268001	1	イトマキウテ"ハ"ネ	THREAD WINDER ARM SPRING	
6-2-6	S13574000	1	シリンダ"クミ	CYLINDER ASSEMBLY	
6-2-6-1	S13575000	1	シリンダ"16X10	CYLINDER 16X10	
6-2-6-2	S06890000	1	スピ"コンツキ"テム5-4	SPEED CONTROLLER JOINT M5-4	
6-2-7	S12642001	2	アナホ"ルト3X35	BOLT 3X35	
6-2-8	028030243	2	ハ"ネサ"カ"ネ2-3	SPRING WASHER 2-3	
6-2-9	S04411001	1	Bクランプ"ヘッド"	(B) CLAMP HEAD	
6-2-10	028030243	1	ハ"ネサ"カ"ネ2-3	SPRING WASHER 2-3	
6-3	018400822	4	アナホ"ルト4X8	BOLT 4X8	
6-4	028040242	4	ハ"ネサ"カ"ネ2-4	SPRING WASHER 2-4	
6-5	S14063001	1	オオオサエR-DTS	BIG PRESSER (RIGHT-DARTS)	
6-6	S14062001	1	オオオサエL-DTS	BIG PRESSER (LEFT-DARTS)	
6-7	S13577000	1	ハ"ルブ"ユニットDTS	VALVE UNIT (DARTS)	
6-7-1	S13578000	1	ハ"ルブ"VZ3120	VALVE VZ3120	
6-7-2	S14145000	1	ハーフユニオン06-M5	HALF UNION 06-M5	
6-7-3	S11426000	1	エルボ"ユニオン4M5	ELBOW UNION 4M5	
6-7-4	156096000	1	M5プラグ"	M5 PLUG	
6-8	002301003	2	+ナヘ"コネシ"3X10	SCREW 3X10	
6-9	028030243	2	ハ"ネサ"カ"ネ2-3	SPRING WASHER 2-3	
6-10	S13579001	1	ハ"ルブ"フ"ラケツト	VALVE BRACKET	
6-11	062400806	2	ナヘ"コ4X8	SCREW 4X8	
6-12	028040243	2	ハ"ネサ"カ"ネ2-4	SPRING WASHER 2-4	
6-13	S08178000	1	ブランチUY-4	BRANCH UY-4	
6-14	S08172000	2	エア-ホ-ス4-K	AIR TUBE 4-K	
6-15	S14146000	1	ブランチUY-6	BRANCH UY-6	
6-16	S08146000	2	エア-ホ-ス6-A	AIR TUBE 6-A	
6-17	S08267003	2	オオオサエゴム	CARRIAGE FEED RUBBER	
6-18	S04557000	7	ハンタイ PLTIM	BAND PLTIM	

X. 特別注文部品(エアージェクター)/Option part (Air ejector)/Sonderteile (Luftausstosser)/  
 Pièce optionnelle (éjecteur d'air)/Pieza opcional (eyector de aire)

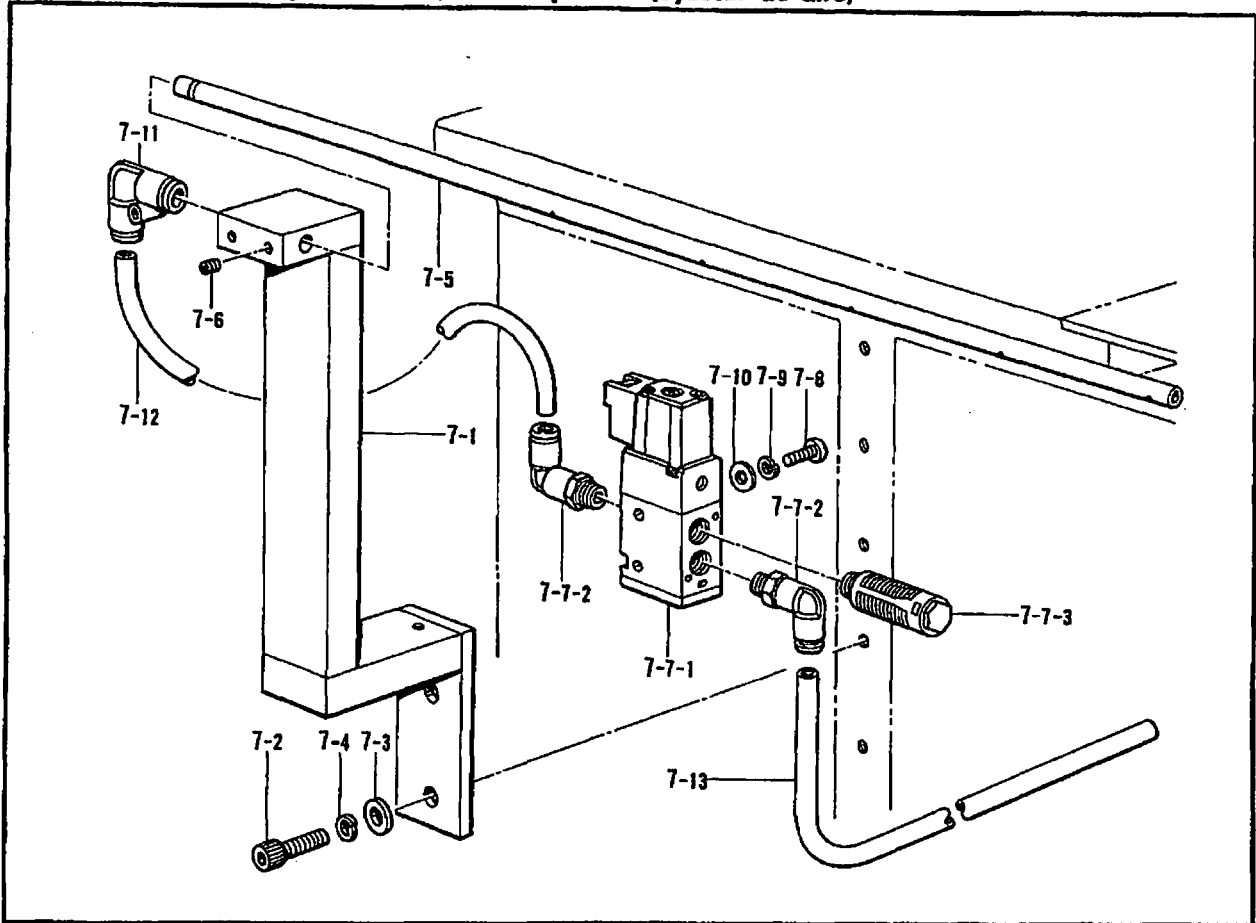

Z1. 付属品関係(自動機付属)/Accessories (provided with automatic sewing machine)/  
 Zubehör (mit automatischer Nähmaschine)/  
 Pièces fournies (avec la machine à coudre automatique)/  
 Piezas accesorias (que vienen con la máquina de coser automática)

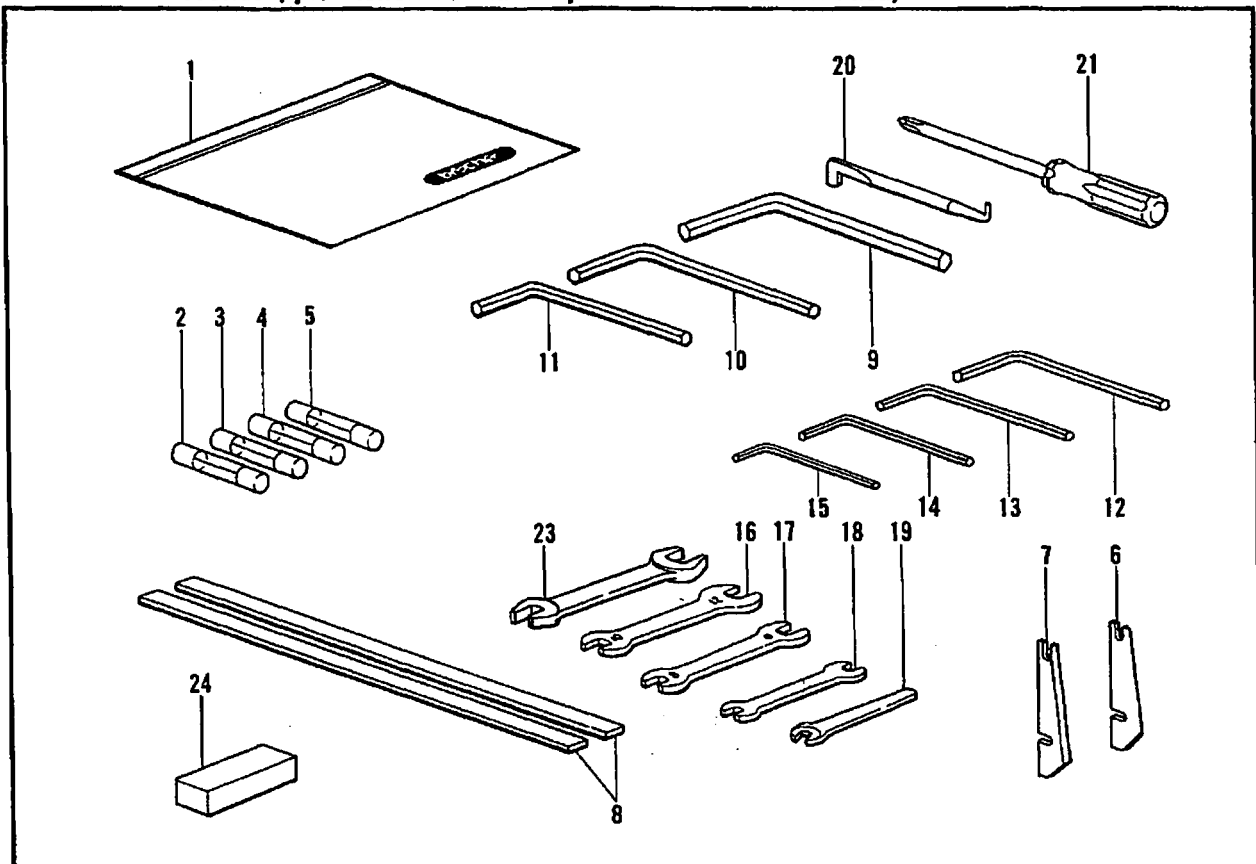

X. 特別注文部品(エアージェクター)/Option part (Air ejector)/Sonderteile (Luftausstosser)/  
Pièce optionnelle (éjecteur d'air)/Pieza opcional (eyector de aire)

REF.NO.	CODE	QTY	ヒンメイ	NAME OF PARTS	RMKS
7	S14155001	1	エアージェクター組み	AIR EJECTOR ASSEMBLY	
7-1	S14156001	1	イシエクタタイ	EJECTOR BRACKET	
7-2	018082022	2	アナボルト8X20	BOLT 8X20	
7-3	025080232	2	ヒラサカネチユウ8	PLAIN WASHER 8	
7-4	028080242	2	ハネサカネ2-8	SPRING WASHER 2-8	
7-5	S14091001	1	スタツカーエアノズル	STACKER AIR NOZZLE	
7-6	014500522	2	アトメネジ5クホミ	SET SCREW 5	
7-7	S14157000	1	バルブユニットSAE	VALVE UNIT (SAE)	
7-7-1	S14158000	1	バルブVZ512	VALVE VZ512	
7-7-2	S14159000	2	エルボ1/8-8	ELBOW 1/8-8	
7-7-3	140682001	1	サイレンサー	SILENCER	
7-8	062302505	2	ナヘコ3X25	SCREW 3X25	
7-9	028030243	2	ハネサカネ2-3	SPRING WASHER 2-3	
7-10	025030233	2	ヒラサカネチユウ3	PLAIN WASHER 3	
7-11	S14160000	1	エルボ	ELBOW	
7-12	S14161000	1	エアース8-C	AIR TUBE 8-C	
7-13	S08361000	1	エアース8-B	AIR TUBE 8-B	

Z1. 付属品関係(自動機付属)/Accessories (provided with automatic sewing machine)/  
Zubehör (mit automatischer Nähmaschine)/  
Pièces fournies (avec la machine à coudre automatique)/  
Piezas accesorias (que vienen con la máquina de coser automática)

REF.NO.	CODE	QTY	ヒンメイ	NAME OF PARTS	RMKS
1	122991001	1	フソクヒンボリフクロ	ACCESSORY BAG	
2	141032000	2	ヒューズ	FUSE (2A)	
3	S08030000	1	Gヒューズ5AFB	G FUSE (5AFB)	
4	153242000	1	ヒューズ6A	FUSE (6A)	
5	219225000	1	カンヒューズ8A	FUSE (8A)	
6	S08322001	2	コーナーメスSR	CORNER KNIFE (SR)	
7	S08302001	2	コーナーメスSL	CORNER KNIFE (SL)	
8	S08267003	2	オオオサエゴム	CORRIAGE FEED RUBBER	
9	115157001	1	6カクホウスハナ6	HEXAGONAL WRENCH 6	
10	150335001	1	6カクホウスハナ5	HEXAGONAL WRENCH 5	
11	118064001	1	6カクホウスハナ4	HEXAGONAL WRENCH 4	
12	142721001	1	6カクホウスハナ3	HEXAGONAL WRENCH 3	
13	154125001	1	6カクホウスハナ2.5	HEXAGONAL WRENCH 2.5	
14	142002001	1	6カクホウスハナ2	HEXAGONAL WRENCH 2	
15	S07783001	1	6カクホウスハナ1.5	HEXAGONAL WRENCH 1.5	
16	107780001	1	スハナ10X12	SPANNER 10X12	
17	100887001	1	スハナ8X9	SPANNER 8X9	
18	142205001	1	スハナ7X8	SPANNER 7X8	
19	S08132001	1	スハナ5.5	SPANNER 5.5	
20	S08170001	1	Zカタネジマワシ	Z-STEEL SCREW DRIVER	
21	150332001	1	プラスチックライハ-N0.2	DRIVER NO.2	
23	S14696001	1	スハナ11X13	SPANNER 11X13	
24	*	1	オオオサエゲージ	CARRIAGE GAUGE	

① 付属品の明細は変更することがあります。  
 ② The details of included accessories are subject to change.  
 ③ Änderungen in der Aufstellung der Mitgelieferten Zubehöre sind vorbehalten.

④ Les détails des accessoires inclus sont sujets à des changements.  
 ⑤ Los detalles de los accesorios incluidos pueden variar.

**Z2. 付属品関係(頭部付属)/Accessories (provided with machine /Zubehör (mit Nähmaschine)/  
Pièces fournies (avec le corps de la machine)/  
Piezas accesorias (que vienen con el cuerpo de la máquina)**

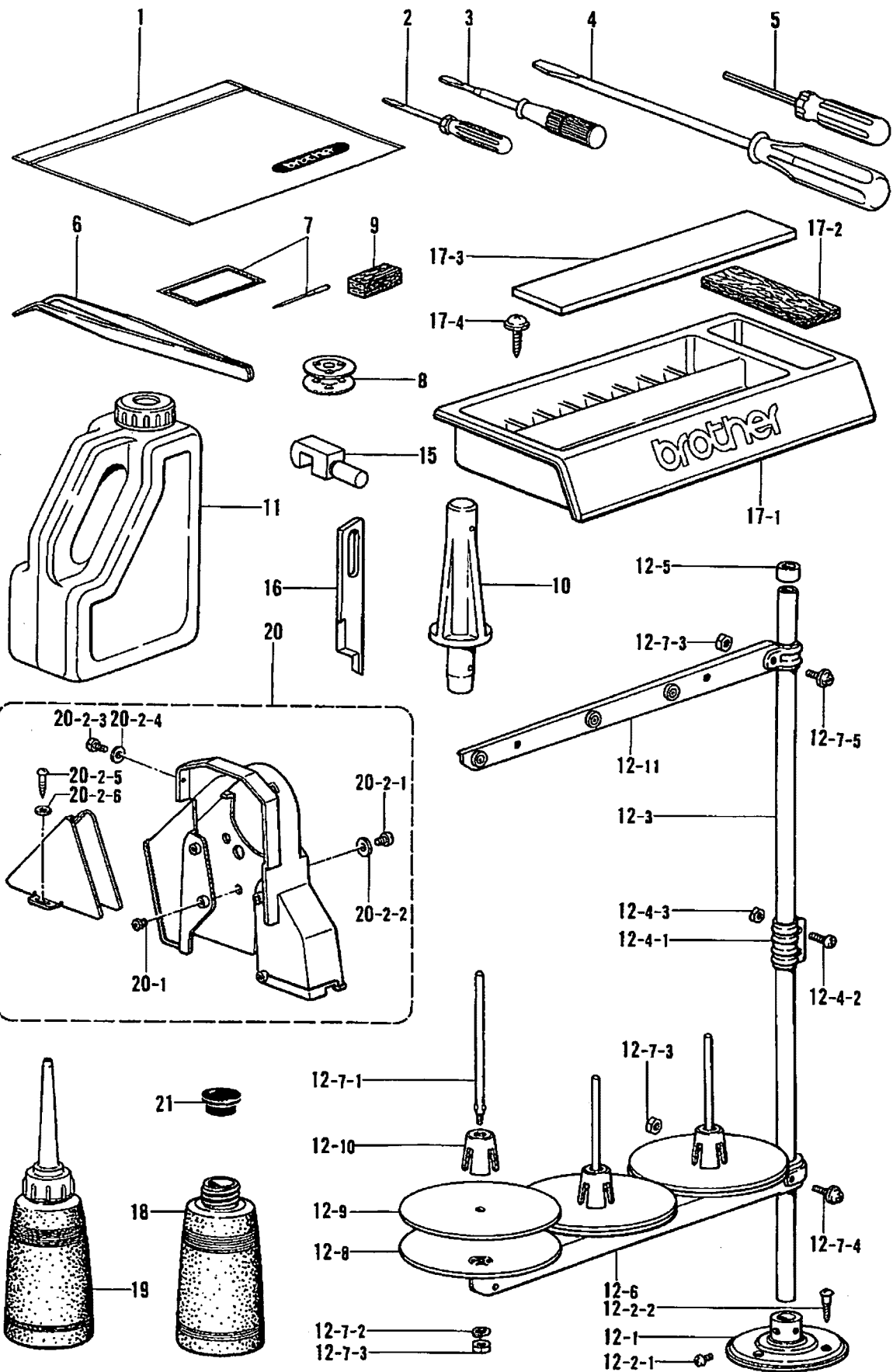

① 付属品の明細は変更することがあります。  
 ② The details of included accessories are subject to change.  
 ③ Änderungen in der Aufstellung der Mitgelieferten Zubehöre sind vorbehalten.

① Les détails des accessoires inclus sont sujets à des changements.  
 ② Los detalles de los accesorios incluidos pueden variar.

22. 付属品関係(頭部付属)/Accessories (provided with machine /Zubehör (mit Nähmaschine)/  
Pièces fournies (avec le corps de la machine)/  
Piezas accesorias (que vienen con el cuerpo de la máquina)





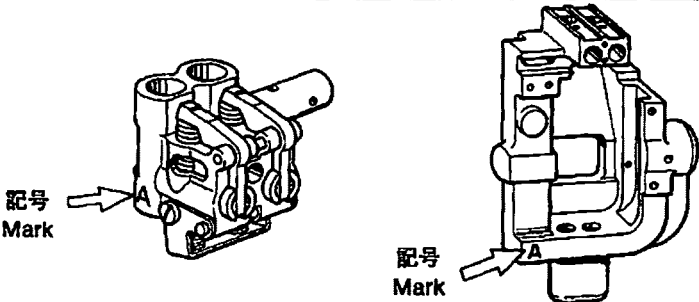

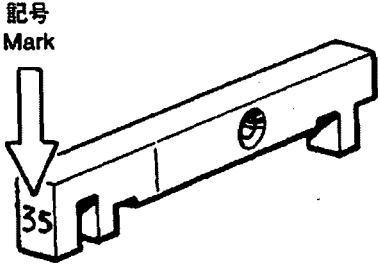

REF.NO.	CODE	QTY	ヒンメイ	NAME OF PARTS	RMKS
1	122991001	1	フツクヒンホリフクロ	ACCESSORY BAG	
2	142443001	1	ネシマワシ1.9X52	SCREW DRIVER 1.9X52	
3	118837001	1	ネシマワシ3.4X70	SCREW DRIVER 3.4X70	
4	101572101	1	ネシマワシ5.5X190	SCREW DRIVER 5.5X190	
5	S01943001	1	6カクホウネシマワシ1.6	HEXAGONAL SCREW DRIVER 1.6	
6	117466000	1	ピンセット	PINCETTE	
7	145646016	8	ミシンハリDPX17	NEEDLE DPX17 #16	
8	S09285001	8	ホビン	BOBBIN	
9	114941001	2	アームイトアンナイフエルト	FELT	
10	159384001	1	トウフササエマクラ	HEAD REST	
11	154702001	1	オイルタンク	OIL TANK	
12	S02765001	1	イトタテダイクミ3	COTTON STAND ASSEMBLY 3	
12-1	150189002	1	ブラケット	COTTON STAND BASE	
12-2	S02773001	1	ブラケットネジセット	COTTON STAND BASE SCREW SET	
12-2-1	062060806	2	ナヘコ6X8	SCREW 6X8	
12-2-2	031452206	3	マルモク45X22	SCREW 45X22	
12-3	150172002	2	コラムパイプ	COLUMN PIPE	
12-4	150106002	1	コラムジョイントクミ	COLUMN JOINT ASSEMBLY	
12-4-1	150173002	1	コラムジョイント	COLUMN JOINT	
12-4-2	062501406	2	ナヘコ5X14	SCREW 5X14	
12-4-3	021500106	2	1シユナツト5	NUT 5	
12-5	150174000	1	コラムキャップ	COLUMN CAP	
12-6	S02779001	1	スプールホルダー-3	SPOOL HOLDER 3	
12-7	S02782001	1	スプールネジセット3	SPOOL SCREW SET 3	
12-7-1	150179002	3	スプールシャフトB	SPOOL SHAFT (B)	
12-7-2	028050246	3	ハネサカネ2-5	SPRING WASHER 2-5	
12-7-3	021500106	5	1シユナツト5	NUT 5	
12-7-4	050503006	1	ナヘコヒラサ5X30	SCREW 5X30	
12-7-5	050501406	1	ナヘコヒラサ5X14	SCREW 5X14	
12-8	150180000	3	ウケサヲ	SPOOL STAND BASE	
12-9	150182000	3	スプールマット	SPOOL MAT	
12-10	126863001	3	スプールクッション	SPOOL CUSHION	
12-11	S02788001	1	スレッドハンガークミ3	THREAD HANGER ASSEMBLY 3	
15	141256001	2	トウブヒンシ	HEAD HINGE	
16	153019001	1	ウウメス	UPPER KNIFE	
17	183400001	1	コモノケースセット	ACCESSORY CASE SET	
17-1	S02738001	1	コモノケース	ACCESSORY CASE	
17-2	S02740000	1	フェルト	FELT	
17-3	S02739000	1	ゴムシヤクテープ	HAGETIC TAPE	
17-4	S10476001	2	ハンフツシヤクツヒンネシ	SCREW	
18	114486002	1	ホリオイルライタイ	OILER	
19	114483002	1	ホリオイルークミ	OILER ASSEMBLY	
20	183480001	1	ベルトカバーークミ	BELT COVER ASSEMBLY	
20-1	S07660000	4	ゴムカラー	RUBBER COLLAR	
20-2-1	062712012	4	ナヘコ476-32X20	SCREW 476X20	
20-2-2	025050332	4	ヒラサカネタ5	PLAIN WASHER 5	
20-2-3	062680812	1	ナヘコ437-40X8	SCREW 437X8	
20-2-4	025680232	1	ヒラサカネチユウ4.37	PLAIN WASHER 4.37	
20-2-5	100666002	2	マルモクネシ5.5X20	SCREW 5.5X20	
20-2-6	025750132	2	ヒラサカネシヨウ5.56	PLAIN WASHER 5.56	

ゲージ部品一覧表/GAUGE PARTS LIST/LEHRENLISTE/  
LISTE DES PIÈCES D'ECARTEMENT/LISTA DE PIEZAS CALIBRADORAS





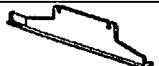

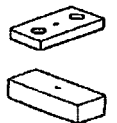

D-1-7	ハリボウダクミ Needle Bar Clamp Assembly	記号 Mark	部品コード Parts. No.
		A	S00858001
		B	S00858002
		C	S00858003

D-1-12	スベリコクミ Slide Block Assembly	記号 Mark	部品コード Parts. No.
		25	S07575000
		30	S07575001
		35	S07575002
		40	S07575003
		45	S07575004
		50	S07575005
		55	S07575006
		60	S07575007
		65	S07575008
		70	S07575009
		75	S07575010
80	S07575011		

- ◎ 上記部品は、テーキンを確認した上、御注文下さい。
- ◎ Check the replacement index for the above parts before ordering.
- ◎ Vor dem Bestellen den Austauschindex obenstehenden Teile kontrollieren.
- ◎ Avant de passer commande, consulter l'index de pièces de rechange pour les pièces ci-dessous.
- ◎ Verificar el codigo de recambio de las piezas a anteriores, antes de hacer el pedido.

品名 Name of Parts		参照番号 Ref. No.	個数 Q'ty	針 巾 Needle Gauge						
				8 m/m	10m/m	12m/m	14m/m	16m/m	18m/m	20m/m
糸切り Thread Trimmer	上糸切り移動刃 Needle Thread Trimmer Movable Knife 	N-6	1	ウワイトメス 8~12 Needle Thread Knife (8~12) (S08403-001)			ウワイトメス 14~16 Needle Thread Knife (14~16) (S10527-001)		ウワイトメス 18~20 Needle Thread Knife (18~20) (S10552-001)	
	上糸切り固定刃 Needle Thread Trimmer Fixed Knife 	N-7	1	コテイハ 8~12 Fixed Knife (8~12) (S08388-001)			コテイハ 14~16 Fixed Knife (14~16) (S10528-001)		コテイハ 18~20 Fixed Knife (18~20) (S10553-001)	
	上糸切り糸保持バネ Needle Thread Trimmer Thread Retainer Spring 	N-8	1	イトホジバネ 8~12 Thread Retainer Spring (8~12) (S08401-001)			イトホジバネ 14~16 Thread Retainer Spring (14~16) (S10529-001)		イトホジバネ 18~20 Thread Retainer Spring (18~20) (S10554-001)	
	下糸切りリンク Lower Thread Trimmer Link 	N-12	1	リンクB Link (B) (S08385-001)	リンクB Link (B) (S08385-002)	リンクB Link (B) (S08385-003)	リンクB Link (B) (S08385-004)	リンクB Link (B) (S08385-005)	リンクB Link (B) (S08385-006)	リンクB Link (B) (S08385-007)
生地ガイドアーム用 Cloth Guide for Arm	スペーサ使用個数 Q'ty of Spacer S08356-001	T-12-58	0	2	4	4	4	4	4	
コーナーメス Corner Knife	台 Base 	T-44	2	メスダイ 8クミ Knife Base Ass 8 (S11521-001)	メスダイ 10クミ Knife Base Ass 10 (S11522-001)	メスダイ 12クミ Knife Base Ass 12 (S11523-001)	メスダイ 14クミ Knife Base Ass 14 (S11524-001)	メスダイ 16クミ Knife Base Ass 16 (S11525-001)	メスダイ 18クミ Knife Base Ass 18 (S11526-001)	メスダイ 20クミ Knife Base Ass 20 (S11527-001)
	刃 (右側) Right Knife 	T-52	2	コーナーメスLR Corner Knife (L-Right) (S09418-001)						
	刃 (左側) Left Knife 	T-53	2	コーナーメスLL Corner Knife (L-Left) (S09417-001)						
バインダー Binder	両玉 Double Welting 	T-54	1	ジョウギクミ 8W Binder Assembly 8W (S14789-001)	ジョウギクミ 10W Binder Assembly 10W (S14713-001)	ジョウギクミ 12W Binder Assembly 12W (S14717-001)	ジョウギクミ 14W Binder Assembly 14W (S14721-001)	ジョウギクミ 16W Binder Assembly 16W (S14725-001)	ジョウギクミ 18W Binder Assembly 18W (S14729-001)	ジョウギクミ 20W Binder Assembly 20W (S14733-001)
	片玉 Single Welting 	T-54	1	ジョウギクミ 8S Binder Assembly 8S (S14711-001)	ジョウギクミ 10S Binder Assembly 10S (S14715-001)	ジョウギクミ 12S Binder Assembly 12S (S14719-001)	ジョウギクミ 14S Binder Assembly 14S (S14723-001)	ジョウギクミ 16S Binder Assembly 16S (S14727-001)	ジョウギクミ 18S Binder Assembly 18S (S14731-001)	ジョウギクミ 20S Binder Assembly 20S (S14735-001)
		T-68	1	オリコミイタオサエ Folding Plate Supporter (S11520-001)						
		T-89	2	+ サラネジ 3 x 5 Screw 3 x 5 (084300-513)						
大押入調節ゲージ Carriage Feed Adjusting Gauge		T-58	1	イドウダイスパーサ Movable Base Spacer (S08513-001)	イドウダイスパーサ Movable Base Spacer (S08513-002)	イドウダイスパーサ Movable Base Spacer (S08513-003)	イドウダイスパーサ Movable Base Spacer (S08513-004)	イドウダイスパーサ Movable Base Spacer (S08513-005)	イドウダイスパーサ Movable Base Spacer (S08513-006)	イドウダイスパーサ Movable Base Spacer (S08513-007)
		Z-24	1	オオオサエゲージ Adjusting Gauge (S08512-001)	オオオサエゲージ Adjusting Gauge (S08512-002)	オオオサエゲージ Adjusting Gauge (S08512-003)	オオオサエゲージ Adjusting Gauge (S08512-004)	オオオサエゲージ Adjusting Gauge (S08512-005)	オオオサエゲージ Adjusting Gauge (S08512-006)	オオオサエゲージ Adjusting Gauge (S08512-007)

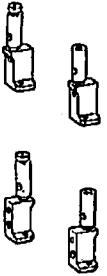

品名 Name of Parts			参照番号 Ref. No.	個数 Q'ty	針 巾 Needle Gauge						
					8m/m	10m/m	12m/m	14m/m	16m/m	18m/m	20m/m
スペーサ Spacer	大押入用 For Carriage Feed	スペーサS Spacer (S) 	T-56	2	t=6 (S08510-001)	t=5 (S08510-002)	t=4 (S08510-003)	t=3 (S08510-004)	t=2 (S08510-005)	t=1 (S08510-006)	t=
		スペーサW Spacer (W) 	T-57	2	t=3.5 (S08511-001)	t=4.5 (S08511-002)	t=5.5 (S08511-003)	t=6.5 (S08511-004)	t=7.5 (S08511-005)	t=8.5 (S08511-006)	t=9.5 (S08511-007)
	折り込み板用 For Folding Plate	スペーサS Spacer (S) 	T-80	2	t=8.5 (S08688-001)	t=7.5 (S08688-002)	t=6.5 (S08688-003)	t=5.5 (S08688-004)	t=4.5 (S08688-005)	t=3.5 (S08688-006)	---
		スペーサW Spacer (W) 	T-81	2	t=3.5 (S08689-001)	t=4.5 (S08689-002)	t=5.5 (S08689-003)	t=6.5 (S08689-004)	t=7.5 (S08689-005)	t=8.5 (S08689-006)	t=9.5 (S08689-007)
フラップ用ゲージ Gauge for Flap 		T-86	2	---	フラップスペーサ Flap Spacer (S11304-002)	フラップスペーサ Flap Spacer (S11304-003)	フラップスペーサ Flap Spacer (S11304-004)	フラップスペーサ Flap Spacer (S11304-005)	フラップスペーサ Flap Spacer (S11304-006)	フラップスペーサ Flap Spacer (S11304-007)	
		T-87	4	---	ナベコ 3×18 Screw 3×18 (082301-606)		ナベコ 3×20 Screw 3×20 (082302-005)		ナベコ 3×25 Screw 3×25 (082302-505)		
生地滑り板 Cloth Slide Plate	右側 Right 	V-141	1	キジスベリイタRクミ Slide Plate (Right) Assembly (S08452-001)			キジスベリイタRクミ Slide Plate (Right) Assembly (S08452-001)			キジスベリイタRクミ Slide Plate (Right) Assembly (S08453-001)	
	左側 Left 	V-142	1	キジスベリイタLクミ Slide Plate (Left) Assembly (S08454-001)			キジスベリイタLクミ Slide Plate (Left) Assembly (S08454-001)			キジスベリイタLクミ Slide Plate (Left) Assembly (S08455-001)	
頭部 Machine Head	針抱き Needle Clamp 	W-1	1	ハリダキ 8Lセット Needle Clamp Set 8L (S14807-001)	ハリダキ 10Lセット Needle Clamp Set 10L (S14808-001)	ハリダキ 12Lセット Needle Clamp Set 12L (S14811-001)	ハリダキ 14Lセット Needle Clamp Set 14L (S14813-001)	ハリダキ 16Lセット Needle Clamp Set 16L (S14815-001)	ハリダキ 18Lセット Needle Clamp Set 18L (S14817-001)	ハリダキ 20Lセット Needle Clamp Set 20L (S14818-001)	
		W-1-1	1	ハリダキクミ 8L Needle Clamp Ass. 8L (S15826-001)	ハリダキクミ 10L Needle Clamp Ass. 10L (S15828-001)	ハリダキクミ 12L Needle Clamp Ass. 12L (S15834-001)	ハリダキクミ 14L Needle Clamp Ass. 14L (S15838-001)	ハリダキクミ 16L Needle Clamp Ass. 16L (S15842-001)	ハリダキクミ 18L Needle Clamp Ass. 18L (S15846-001)	ハリダキクミ 20L Needle Clamp Ass. 20L (S15850-001)	
		W-2	1	ハリダキ 8Rセット Needle Clamp Set 8R (S14808-001)	ハリダキ 10Rセット Needle Clamp Set 10R (S14810-001)	ハリダキ 12Rセット Needle Clamp Set 12R (S14812-001)	ハリダキ 14Rセット Needle Clamp Set 14R (S14814-001)	ハリダキ 16Rセット Needle Clamp Set 16R (S14816-001)	ハリダキ 18Rセット Needle Clamp Set 18R (S14818-001)	ハリダキ 20Rセット Needle Clamp Set 20R (S14820-001)	
		W-2-1	1	ハリダキクミ 8R Needle Clamp Ass. 8R (S15827-001)	ハリダキクミ 10R Needle Clamp Ass. 10R (S15831-001)	ハリダキクミ 12R Needle Clamp Ass. 12R (S15835-001)	ハリダキクミ 14R Needle Clamp Ass. 14R (S15839-001)	ハリダキクミ 16R Needle Clamp Ass. 16R (S15843-001)	ハリダキクミ 18R Needle Clamp Ass. 18R (S15847-001)	ハリダキクミ 20R Needle Clamp Ass. 20R (S15851-001)	
	針板 Needle Plate 	W-3	1	ハリイタ 8 Needle Plate 8 (S08461-001)	ハリイタ 10 Needle Plate 10 (153022-001)	ハリイタ 12 Needle Plate 12 (158060-001)	ハリイタ 14 Needle Plate 14 (S08462-001)	ハリイタ 16 Needle Plate 16 (S08463-001)	ハリイタ 18 Needle Plate 18 (S08464-001)	ハリイタ 20 Needle Plate 20 (S08465-001)	

品名 Name of Parts	参照番号 Ref. No.	個数 Q'ty	針 巾 Needle Gauge						
			8 m/m	10m/m	12m/m	14m/m	16m/m	18m/m	20m/m
刃 (右側) Knife (Right)	T-52	2	コーナーメスSR Corner Knife (S-Right) (S08322-001)						
刃 (左側) Knife (Left)	T-53	2	コーナーメスSL Corner Knife (S-Left) (S08302-001)						
メス台 Knife Base	W-4	1	メスダイ8セット Knife Base Set 8 (S15881-001)	メスダイ10セット Knife Base Set 10 (S15882-001)	メスダイ12セット Knife Base Set 12 (S15883-001)	メスダイ14セット Knife Base Set 14 (S15884-001)	メスダイ16セット Knife Base Set 16 (S15885-001)	メスダイ18セット Knife Base Set 18 (S15886-001)	メスダイ20セット Knife Base Set 20 (S15887-001)
	W-4-1	1	メスダイ8クミ Knife Base Ass. 8 (S14737-001)	メスダイ10クミ Knife Base Ass. 10 (S14738-001)	メスダイ12クミ Knife Base Ass. 12 (S14741-001)	メスダイ14クミ Knife Base Ass. 14 (S14743-001)	メスダイ16クミ Knife Base Ass. 16 (S14745-001)	メスダイ18クミ Knife Base Ass. 18 (S14747-001)	メスダイ20クミ Knife Base Ass. 20 (S14749-001)
特別注文部品 Option Parts セラミックコーナーメス (S) Ceramic Corner Knife (Small)	W-5-1	4	(S14050-001)						
セラミックコーナーメス (L) Ceramic Corner Knife (Large)	W-5-2	4	(S14051-001)						
OFジョウギクミ Offset Binder	W-6-1	1	—	A・B=9:1 (S15602-001)	—				
OFジョウギクミ Offset Binder	W-6-2	1	—	A・B=11:1 (S15604-001)		—			
OFジョウギクミ Offset Binder	W-6-3	1	—			A・B=13:1 (S15608-001)	—		

品名 Name of Parts	参照番号 Ref. No.	個数 Q'ty	t=2m/m	t=3m/m	t=4m/m	t=5m/m	t=8m/m
オオオサエゴム Carriage Feed Rubber	R-55	2	S08267-002	S08267-003	S08267-004	S08267-005	S08267-008

索引 / INDEX / VERZEICHNIS / INDEX / INDICE

CODE	REF.NO.	PAGE
S09265001	G - 23	10
S00208001	F - 42	8
S00402001	X - 3-1	66
S00403000	V - 25	58
S00480000	K - 1-11	18
S00554000	S - 6	38
S00603000	V - 112-4	60
S00614000	V - 112-2	60
S00617000	V - 116	60
S01522000	R - 15-5	34
	R - 45-5	36
S01542000	R - 19-5	34
S01698001	T - 21	48
S01830000	U - 1-35	56
S01943001	Z2 - 5	72
S02611001	K - 1-23-1	18
S02612001	K - 1-23-2	18
S02738001	Z2 - 17-1	72
S02739000	Z2 - 17-3	72
S02740000	Z2 - 17-2	72
S02765001	Z2 - 12	72
S02773001	Z2 - 12-2	72
S02779001	Z2 - 12-6	72
S02782001	Z2 - 12-7	72
S02788001	Z2 - 12-11	72
S03289001	H - 60	12
	H - 73	12
S03557001	T - 26-18	54
S03566001	K - 1-18	18
S04411001	X - 6-1-9	68
	X - 6-2-9	68
S04557000	K - 1-26	18
	L - 1-79	22
	L - 2-29	24
	L - 2-63	26
	R - 36	34
	S - 18	38
	S - 21	38
	V - 134	60
	X - 4-4	66
	X - 6-18	68
S04607001	X - 4-1-2	66
S04891000	R - 7	34
S04897000	R - 15-6	34
	R - 19-6	34
	R - 45-6	36
S04905000	F - 50-2	8
S04910000	L - 1-22-2	20
	L - 1-38-2	20
	L - 2-41-2	24
	T - 1-55-3	40
S06241000	P - 4	32
S06242001	P - 5	32
S06694001	U - 1-1-3	56
S06736001	L - 2-5	24
S06737000	L - 2-6	24
S06739001	L - 2-11	24
S06740001	L - 2-15	24
S06741001	L - 2-16	24
S06744000	L - 2-25	24
S06857000	R - 8	34
S06858000	R - 8-1	34
S06859000	R - 8-2	34
S06866000	T - 1-55-2	40
S06882000	N - 9-4-2	30
	T - 25-52-2	50
	T - 25-55-3	52

CODE	REF.NO.	PAGE
S06883000	D - 3-2	6
	N - 1-15-2	30
	T - 25-52-3	50
	T - 25-55-2	52
S06886000	L - 2-26-1-2	24
	T - 1-92-2	42
S06890000	T - 26-2-2	54
	T - 35-2	54
	X - 6-1-6-2	68
	X - 6-2-6-2	68
S06897000	L - 2-26-1-1	24
S06898000	T - 12-15-2	46
S07026001	V - 69	60
S07320000	V - 141-2	62
	V - 142-2	62
S07330101	B - 3	2
S07334001	B - 22	2
S07339001	B - 26	2
S07340001	B - 19	2
S07417001	G - 9	10
S07419001	G - 8	10
S07420000	G - 7	10
S07423101	G - 19	10
S07424001	G - 20	10
S07430001	G - 28	10
S07431001	G - 30	10
S07432001	G - 38	10
S07433001	G - 39	10
S07434001	G - 34	10
S07435001	G - 36	10
S07436001	G - 24	10
S07437001	G - 25	10
S07439001	E - 4	6
S07442001	E - 7	6
S07446001	E - 6	6
S07447001	E - 6-1	6
S07448001	H - 1	12
S07449000	H - 2	12
S07450100	H - 24	12
S07453000	H - 47	12
S07454000	H - 48	12
S07455100	H - 49	12
S07456000	H - 50	12
S07457100	H - 51	12
S07458100	H - 53	12
S07459100	H - 54	12
S07460100	H - 46	12
S07461000	H - 63	12
S07462000	H - 69	12
S07463000	H - 70	12
S07464100	H - 74	12
S07467001	H - 78	12
S07468000	H - 80	12
S07469001	H - 81	12
S07470001	H - 82	14
S07471001	H - 22	12
S07473000	H - 86	14
S07476000	H - 36	12
S07477000	H - 4	12
S07478000	H - 5	12
S07479101	H - 6	12
S07481000	H - 87	14
S07487001	J - 1-6	16
S07488001	J - 1-10	16
S07489101	J - 1	16
S07490001	J - 1-13	16
S07567001	B - 24	2

CODE	REF.NO.	PAGE
S07571000	H - 39	12
S07574001	C - 1-10	4
S07586001	D - 11	6
S07658001	G - 27	10
S07660000	Z2 - 20-1	72
S07783001	Z1 - 15	70
S07810000	H - 52	12
S07876001	H - 91	14
	H - 98	14
	H - 99	14
S08007000	L - 1-80-3	22
	L - 2-64-1	26
S08009000	T - 17-2	48
S08017000	L - 1-80-4	22
	L - 2-64-2	26
	T - 17-1-1	48
S08021101	Q - 1	32
S08030000	Z1 - 3	70
S08086000	S - 7	38
S08089001	V - 112	60
S08093000	Q - 2-2	32
S08098000	S - 5	38
S08103000	S - 4	38
S08105000	S - 8	38
S08106000	S - 9	38
S08108000	S - 10	38
S08109000	S - 11	38
S08110000	S - 12	38
S08113000	S - 17	38
S08114001	S - 13	38
S08115000	S - 14	38
S08116000	S - 15	38
S08117000	K - 1-8	18
S08121000	S - 20	38
S08124101	L - 2	24
S08125000	L - 2-27	24
S08126000	L - 2-28	24
S08127001	L - 1-80	22
S08130000	L - 2-64	26
S08131000	L - 1-80-1	22
S08132001	Z1 - 19	70
S08134000	L - 3	26
S08135001	L - 1-72	22
	L - 2-57	26
S08137000	T - 24	48
S08138000	L - 1-75	22
S08139000	L - 1-76	22
	L - 2-60	26
S08140000	L - 1-77	22
	L - 2-61	26
S08142001	T - 25-45	50
S08143000	R - 9	34
S08144000	R - 10	34
S08145000	R - 11	34
S08146000	R - 13	34
	X - 6-16	68
S08147000	R - 14	34
S08148001	T - 25-72	52
S08149001	T - 25-62	52
S08151000	L - 1-72-1	22
	L - 2-57-1	26
	R - 19-1	34
	R - 45-1	36
S08152000	L - 1-72-5	22
	L - 2-57-5	26
S08154000	L - 1-72-2	22
	L - 2-57-2	26

CODE	REF.NO.	PAGE
S08155000	R - 15-2	34
	R - 19-2	34
	R - 45-2	36
S08159001	R - 19	34
S08163000	R - 22	34
S08164000	R - 23	34
S08165000	R - 24	34
S08166000	R - 25	34
S08167000	R - 26	34
S08168000	R - 27	34
S08169000	R - 28	34
S08170001	Z1 - 20	70
S08171000	R - 29	34
S08172000	R - 30	34
	X - 6-14	68
S08173000	R - 31	34
S08174000	R - 32	34
S08175000	R - 33	34
S08176000	R - 34	34
S08177000	R - 35	34
S08178000	R - 16	34
	X - 6-13	68
S08180000	T - 1-71	42
S08185001	V - 9	58
S08186001	V - 10	58
S08187001	V - 12	58
S08189001	V - 19	58
S08190001	V - 40	58
S08191001	V - 23	58
S08192001	V - 91	60
S08193001	V - 13	58
S08194001	V - 29	58
S08196001	V - 141-1	62
S08196002	V - 141-1	62
S08196003	V - 141-1	62
S08197001	V - 67	58
S08199001	V - 142-1	62
S08199002	V - 142-1	62
S08199003	V - 142-1	62
S08200001	V - 59	58
S08201001	V - 64	58
S08205000	V - 54	58
S08206002	V - 73	60
S08207001	T - 25-61	52
S08208001	T - 38	54
S08211001	T - 29-1	54
S08213001	T - 29-2	54
S08214001	T - 33	54
S08215001	T - 29-6	54
S08216001	T - 25-66	52
S08217001	T - 25-31	50
S08220001	V - 125	60
S08221001	V - 80	60
S08222001	V - 82-1	60
S08224001	V - 97	60
S08225001	V - 98	60
S08227001	T - 25	50
S08228001	T - 25-1	50
S08229001	T - 25-5	50
S08230001	T - 25-9	50
S08231000	T - 25-11	50
S08232000	T - 25-12	50
S08233000	T - 25-16	50
S08234001	T - 25-29	50
S08235001	T - 25-32	50
S08237001	T - 25-34	50
S08238000	T - 12-25	46

CODE	REF.NO.	PAGE
S08238000	T - 12-4	46
	T - 25-35	50
S08239000	T - 12-26	46
	T - 12-5	46
	T - 25-36	50
S08240000	T - 12-27	46
	T - 12-6	46
	T - 25-37	50
S08241001	T - 25-39	50
S08242000	T - 25-42	50
S08243000	T - 29-3-1	54
S08245001	T - 25-18	50
S08246001	T - 25-19	50
S08247001	T - 25-25	50
S08248001	T - 25-22	50
S08249000	T - 25-47	50
S08250000	T - 25-52	50
S08251000	T - 25-52-1	50
S08252000	T - 25-42-1	50
S08253000	T - 25-56	52
S08254001	T - 25-68	52
S08255001	T - 25-69	52
S08256001	T - 25-63	52
S08257001	T - 25-75	52
S08258101	T - 25-77	52
S08259101	T - 25-78	52
S08260001	T - 25-80	52
S08261001	T - 25-81	52
S08262001	T - 62	52
S08263001	T - 63	52
S08264001	T - 25-84	52
S08266001	T - 26-23	54
S08267003	X - 6-17	68
	Z1 - 8	70
S08268001	T - 26-1	54
S08270001	V - 32	58
S08271000	T - 26-2	54
S08272000	T - 26-2-1	54
S08273001	T - 26-5	54
S08275001	T - 26-9	54
S08276001	T - 26-10	54
S08277001	T - 26-12	54
S08278001	T - 26-13	54
S08279000	T - 26-17	54
S08280000	T - 1-9	40
S08281001	T - 26	54
S08282101	T - 1	40
S08283001	V - 36	58
S08284001	T - 1-1	40
S08285001	T - 2	42
S08286000	T - 1-2	40
S08287000	T - 8	42
S08288000	T - 11	42
S08289001	T - 1-3	40
S08290001	T - 1-5	40
S08291001	T - 1-6	40
S08292000	T - 1-7	40
S08293001	T - 1-10	40
S08294001	T - 1-12	40
S08295000	T - 1-16	40
S08296001	T - 1-83	42
S08297001	T - 1-82	42
S08298000	T - 1-35	40
S08300001	T - 1-22	40
	T - 1-37	40
S08301001	T - 1-26	40
S08302001	Z1 - 7	70

CODE	REF.NO.	PAGE
S08303001	T - 1-68	42
S08304001	T - 1-30	40
S08306000	T - 1-32	40
S08308001	T - 1-69	42
S08309001	T - 1-34	40
S08310001	T - 1-41	40
S08315000	T - 1-98	42
S08317001	T - 1-45	40
S08318001	T - 1-48	40
S08320001	T - 1-53	40
S08322001	Z1 - 6	70
S08323000	T - 1-55	40
S08324000	T - 1-55-1	40
S08325001	T - 1-56	40
S08326000	T - 1-57	42
S08327001	T - 1-61	42
S08328001	T - 1-63	42
S08329001	T - 1-67	42
S08332000	T - 12-24	46
	T - 12-3	46
	T - 25-33	50
	T - 12-8	46
S08333001	T - 12-8	46
S08334001	T - 12-28	46
S08335000	T - 12-15	46
S08336000	T - 12-15-1	46
S08337001	T - 26-25	54
S08338001	T - 12-21	46
S08339001	T - 12-22	46
S08340001	T - 12-29	46
S08341001	T - 12-20	46
S08342001	T - 12-7	46
S08343000	T - 12-31	46
S08344001	T - 12-34	46
S08345001	T - 12-37	46
S08346001	T - 12-44	46
S08347001	T - 12-47	46
S08348001	T - 12-48	46
S08349001	T - 12-51	46
S08350001	T - 12-54	46
S08352000	L - 2-26-2	24
	T - 12-16	46
S08355001	T - 12-64	48
S08356001	T - 12-56	46
S08360001	T - 12-10	46
S08361000	L - 1-78	22
	L - 2-62	26
	X - 7-13	70
	L - 1-1	20
S08363001	L - 1-1	20
S08364001	T - 12-69	48
S08365001	T - 13	48
S08367000	T - 17-1	48
S08368001	V - 30	58
S08372001	T - 12-75	48
S08377001	N - 9-2	30
S08381001	N - 9-8	30
S08382001	N - 9-9	30
S08383001	N - 9-12	30
S08384001	N - 9-14	30
S08386001	N - 9-16	30
S08387000	N - 9-4	30
S08388000	N - 9-4-1	30
S08397000	N - 1-2	30
	T - 25-58	52
S08398001	L - 1-52	20
S08400000	T - 1-21	40
S08406000	N - 1-15	30
S08407000	N - 1-15-1	30

CODE	REF.NO.	PAGE
S08408000	F - 53	8
S08409001	U - 1	56
S08411001	U - 1-8	56
S08412001	U - 1-8-1	56
S08413001	U - 1-10	56
S08416000	U - 1-11	56
S08417000	U - 1-12	56
S08418000	U - 1-14	56
S08419001	U - 1-18	56
S08420000	U - 1-19	56
S08421000	U - 1-23	56
S08422000	U - 1-24	56
S08423001	U - 1-25	56
S08424001	U - 1-29	56
S08426001	U - 1-33	56
S08427001	V - 93	60
S08431101	L - 1	20
S08432001	L - 1-1-1	20
S08433000	L - 1-1-2	20
S08434001	L - 1-4	20
S08435001	L - 1-5	20
S08436001	L - 1-7	20
S08437001	L - 1-8	20
S08438001	L - 1-11	20
S08439001	L - 1-12	20
S08440000	L - 1-13	20
S08441001	L - 1-14	20
S08442001	L - 1-15	20
S08443001	L - 1-18	20
S08444000	L - 1-20	20
S08445001	L - 1-21	20
S08446000	L - 1-22	20
S08447000	L - 1-22-1	20
S08448001	L - 1-23	20
S08449001	L - 1-37	20
S08450001	L - 1-27	20
S08458001	L - 1-52-1	20
S08459000	L - 1-52-2	20
	L - 1-56	22
S08460001	L - 1-57	22
S08470001	L - 1-64	22
S08471001	L - 1-68	22
S08488000	N - 1-15-3	30
	T - 1-55-4	40
S08489000	T - 25-55-1	52
S08493000	T - 25-55	52
S08498000	T - 25-42-2	50
	T - 29-3-2	54
S08499000	T - 29-3	54
S08500000	N - 1-15-4	30
S08501000	T - 1-55-5	40
S08502000	T - 17	48
S08507000	T - 25-57	52
S08509001	T - 1-100	42
	T - 1-70	42
	T - 25-67	52
	T - 26-19	54
S08514001	L - 1-35	20
	L - 2-38	24
S09132001	C - 5	4
S09141000	R - 43	34
S09142000	V - 138	60
S09149001	C - 1-6	4
S09151001	C - 1-5	4
S09153001	T - 1-78	42
S09155000	T - 1-73	42
S09156000	T - 1-73-1	42

CODE	REF.NO.	PAGE
S09157000	T - 1-20	40
S09162001	C - 1	4
S09170000	T - 1-101	42
S09174000	T - 35	54
S09175000	T - 35-1	54
S09253001	B - 21	2
S09255201	G - 1	10
S09259001	G - 5	10
S09260001	G - 6-1	10
S09261001	G - 6-2	10
S09262101	G - 15	10
S09267001	G - 23-1-1	10
S09274001	G - 23-1-2	10
S09279001	G - 23-2	10
S09285001	G - 41	10
	Z2 - 8	72
S09287000	E - 1	6
S09288000	E - 2	6
S09364000	H - 94	14
S09369000	H - 93	14
S09399001	K - 1	18
S09400001	K - 1-1	18
S09401001	K - 1-2	18
S09402001	K - 1-6	18
S09403001	K - 1-14	18
S09406000	L - 1-38	20
	L - 2-41	24
S09407000	L - 1-38-1	20
	L - 2-41-1	24
S09446001	T - 26-20	54
S09447001	T - 29	54
S09448000	V - 147	62
	V - 15	58
S09449001	V - 63	58
S09450001	V - 99	60
S09618001	L - 1-43	20
	L - 2-52	24
S09619001	L - 1-44	20
	L - 2-55	24
S09670001	B - 20	2
S09685001	T - 1-102	42
S09687001	X - 2-1	66
S09690001	V - 74	60
S10268001	X - 6-1-5	68
	X - 6-2-5	68
S10476001	Z2 - 17-4	72
S10540000	T - 10	42
S10551001	T - 26-3	54
S10557000	R - 44	34
S10559001	V - 82	60
S11083000	X - 5-1-1	66
S11084001	X - 5-2	66
S11148001	X - 3	66
S11334001	X - 4-1	66
S11335001	X - 4-1-1	66
S11336001	X - 4-1-7	66
S11337000	S - 27	38
S11338000	S - 28	38
S11426000	X - 6-7-3	68
S11502001	X - 2	66
S11503001	X - 4	66
S11504001	X - 5	66
S11505000	X - 5-1	66
S11506000	X - 5-1-2	66
S11520001	T - 68	52
S11685000	L - 2-26-1	24
S12445001	E - 5	6

CODE	REF.NO.	PAGE
S12642001	X - 6-1-7	68
	X - 6-2-7	68
S13021001	G - 16	10
S13084001	T - 25-91	52
S13085001	W - 1-4	64
	W - 2-4	64
S13570001	X - 6-1-1	68
S13571001	X - 6-2-1	68
S13572001	X - 6-1-2	68
S13573001	X - 6-2-2	68
S13574000	X - 6-1-6	68
	X - 6-2-6	68
S13575000	X - 6-1-6-1	68
	X - 6-2-6-1	68
S13576000	X - 6-1-3	68
	X - 6-2-3	68
S13577000	X - 6-7	68
S13578000	X - 6-7-1	68
S13579001	X - 6-10	68
S13616001	G - 23-1	10
S13638001	T - 1-89	42
S13639000	T - 1-92	42
S13640000	T - 1-92-1	42
S13641001	T - 1-95	42
S14050001	W - 5-1	64
S14051001	W - 5-2	64
S14062001	X - 6-6	68
S14063001	X - 6-5	68
S14091001	X - 7-5	70
S14118000	S - 30	38
S14145000	X - 6-7-2	68
S14146000	R - 48	36
	X - 6-15	68
S14155001	X - 7	70
S14156001	X - 7-1	70
S14157000	X - 7-7	70
S14158000	X - 7-7-1	70
S14159000	X - 7-7-2	70
S14160000	X - 7-11	70
S14161000	X - 7-12	70
S14189000	H - 100	14
S14197000	U - 1-32	56
S14402001	Q - 2	32
S14402002	Q - 2	32
S14406000	Q - 2-1	32
S14412000	S - 1	38
S14413000	S - 2	38
S14414001	S - 16	38
S14640001	A - 2	2
S14642001	F - 2	8
S14643001	F - 11	8
S14647001	F - 14	8
S14649001	F - 15	8
S14650001	F - 16	8
S14651001	F - 17	8
S14652001	F - 21-3	8
S14653001	F - 25	8
S14654001	F - 26	8
S14655001	F - 28	8
S14656001	F - 30	8
S14657001	F - 32	8
S14658001	F - 34	8
S14659001	F - 41	8
S14660001	F - 43	8
S14661001	F - 45	8
S14665000	F - 50	8
S14666000	F - 50-1	8

CODE	REF.NO.	PAGE
S14667001	F - 51	8
S14668001	B - 5	2
S14669001	D - 10	6
S14670001	D - 1	6
S14671001	D - 6	6
S14672000	D - 3	6
S14673000	D - 3-1	6
S14674001	F - 3	8
S14675001	P - 6	32
S14677001	J - 5	16
S14685001	H - 127	14
S14689001	N - 1-1	30
S14690001	N - 1-12	30
S14691001	N - 1-14	30
S14692001	N - 9-1	30
S14693001	N - 9-5	30
S14694001	N - 9-6	30
S14695001	R - 45	36
S14696001	Z1 - 23	70
S14697000	R - 49	36
S14698001	T - 12	46
S14699001	T - 12-1	46
S14700001	T - 12-2	46
S14701000	T - 12-61	48
S14702000	T - 12-62	48
S14703001	T - 12-73	48
S14704100	T - 12-77	48
S14705000	T - 12-78	48
S14752001	W - 4-2	64
S14753001	T - 45	44
	W - 4-4	64
S14754001	T - 1-52	40
S14795001	V - 2	58
S14796001	V - 44	58
S14797001	V - 49	58
S14798001	V - 50	58
S14799001	T - 1-31	40
S14800001	T - 12-58	46
S14801001	T - 12-57	46
S14802001	N - 1-9	30
S15061001	L - 1-48	20
S15062001	L - 1-59	22
	L - 2-47	24
S15063001	L - 2-1	24
S15064001	L - 2-10	24
S15065001	L - 2-30	24
S15066001	L - 2-40	24
S15067001	V - 120	60
S15068101	G - 2	10
S15076101	R - 15	34
S15077000	R - 15-1	34
S15096000	J - 12	16
S15097000	J - 12-1	16
S15163000	T - 1-36	40
S15201001	T - 1-74	42
S15202001	T - 39	42
S15203000	T - 40	42
S15361001	S - 3	38
S15590001	T - 1-86	42
S15591001	T - 1-97	42
S15601001	V - 8	58
S15602001	W - 6-1	64
S15604001	W - 6-2	64
S15606001	W - 6-3	64
S15673001	V - 89	60
S15871000	J - 12-2	16
S15890001	X - 6	68

CODE	REF.NO.	PAGE
S15891001	X - 6-1	68
S15892001	X - 6-2	68
S16114001	H - 7	12
S16146001	N - 1	30
S16147001	N - 9	30
S16162000	R - 1	34
S16198000	S - 31	38
S16248001	W - 7	64
S16255001	V - 121	60
S16471001	D - 8	6
S16603000	T - 12-79	48
S16667000	M - 1-28-1	28
S16699000	M - 1-28	28
S16700000	M - 1-28-3	28
002301003	X - 6-8	68
002301203	V - 104	60
002402502	L - 1-81	22
004300513	M - 1-3	28
	T - 29-7	54
	T - 64	52
	T - 69	52
004300602	V - 68	58
004301003	V - 75	60
004401003	T - 25-90	52
	T - 34	54
	V - 135	60
007300613	M - 1-30	28
008300604	V - 90	60
008400604	U - 1-34	56
	V - 11	58
	V - 122	60
	V - 14	58
	V - 156	62
	X - 2-2	66
011679312	D - 14	6
013710512	G - 10	10
013711012	G - 17	10
013719412	A - 8	2
013780710	B - 4	2
	C - 4	4
013781012	B - 2	2
	B - 23	2
	E - 3	6
	F - 10	8
	F - 18	8
	F - 27	8
	F - 29	8
	F - 8	8
014060622	L - 1-36	20
	L - 2-39	24
	T - 1-11	40
	T - 1-4	40
	T - 12-23	46
	T - 12-30	46
014300322	T - 43	44
014300332	M - 1-7	28
	T - 12-76	48
014300522	T - 12-82	48
014400422	N - 9-3	30
	T - 1-54	40
	T - 12-55	46
	T - 12-65	48
	T - 46	44
014400522	T - 26-11	54
014400822	U - 1-13	56
014500522	K - 1-24	18
	L - 1-63	22

CODE	REF.NO.	PAGE
014500522	L - 2-21	24
	L - 2-51	24
	T - 1-62	42
	T - 1-84	42
	T - 25-26	50
	X - 7-6	70
014501222	T - 25-30	50
	T - 25-76	52
	T - 9	42
014680422	M - 1-10	28
014680622	G - 33	10
	G - 37	10
014771022	B - 15	2
	E - 6-4	6
	E - 8	6
	C - 7	4
014821022	B - 16	2
016771032	V - 115	60
017062503	V - 70	60
017082203	R - 2	34
018061222	L - 1-65	22
018061622	T - 1-75	42
	V - 55	58
018062022	T - 1-93	42
	T - 12-38	46
	T - 25-48	50
	V - 37	58
	V - 45	58
018062522	L - 1-60	22
	L - 2-48	24
	T - 1-17	40
	T - 1-58	42
	T - 3	42
018063022	C - 5-1	4
018081222	L - 1-32	20
	L - 2-17	24
	L - 2-35	24
018082022	L - 1-28	20
	L - 1-49	20
	L - 2-2	24
	L - 2-31	24
	U - 1-5	56
	V - 41	58
	X - 7-2	70
018082522	L - 2-12	24
	T - 12-17	46
	T - 25-13	50
	V - 48	58
018083022	T - 25-2	50
	T - 25-6	50
018300622	N - 9-13	30
	N - 9-15	30
018300822	N - 1-10	30
	N - 1-3	30
	N - 1-6	30
	T - 1-27	40
	V - 94	60
018301222	T - 12-49	46
	T - 12-52	46
	T - 12-59	46
018400622	X - 4-1-8	66
018400822	T - 25-73	52
	X - 6-3	68
018401022	L - 1-2	20
	N - 3	30
	T - 25-10	50
018401222	N - 9-7	30



CODE	REF.NO.	PAGE
018401222	T - 1-13	40
	T - 25-59	52
	T - 47	44
	U - 1-26	56
	V - 100	60
018401422	W - 4-5	64
	T - 26-14	54
018401622	T - 1-90	42
	T - 25-70	52
	U - 1-36	56
	V - 51	58
	V - 6	58
018402032	V - 65	58
	T - 41	44
018402522	T - 25-53	50
	T - 29-4	54
	V - 101	60
018403022	N - 2	30
018500822	T - 27	54
	V - 33	58
	D - 4	6
018501022	L - 1-69	22
	T - 12-66	48
	T - 25-17	50
018501222	V - 20	58
	T - 1-87	42
018501422	T - 25-20	50
	V - 3	58
018501622	L - 1-24	20
	L - 1-46	20
	L - 2-53	24
	N - 10	30
	T - 1-42	40
	T - 1-64	42
	T - 12-35	46
	T - 12-41	46
	T - 12-45	46
	T - 12-70	48
	T - 14	48
	T - 25-79	52
	T - 6	42
	L - 1-16	20
	T - 1-49	40
	T - 1-79	42
	T - 18	48
T - 25-27	50	
T - 25-40	50	
T - 30	54	
018502522	T - 25-23	50
018503022	L - 1-73	22
	L - 2-58	26
	R - 17	34
	R - 20	34
	R - 46	36
018504032	T - 1-46	40
	T - 25-88	52
018505022	L - 2-7	24
018680822	D - 9	6
021060102	V - 58	58
	V - 62	58
021060106	U - 1-1-4	56
	U - 1-37	56
	U - 1-8-2	56
021060206	T - 25-51	50
	T - 25-64	52
021080206	L - 1-9	20
	T - 1-72	42

CODE	REF.NO.	PAGE
021080206	T - 12-11	46
	T - 12-9	46
021120304	V - 26	58
	X - 3-2	66
	K - 1-5	18
021200203	V - 151	62
	V - 78	60
021300103	T - 12-53	46
	T - 12-60	48
021300303	M - 1-27	28
	X - 2-3	66
021400103	X - 5-3	66
	K - 1-22	18
021400202	T - 26-8	54
	T - 29-9	54
021500103	T - 25-28	50
	Z2 - 12-4-3	72
021500106	Z2 - 12-7-3	72
	J - 1-20	16
021670102	N - 1-4	30
	N - 1-7	30
025030132	T - 26-27	54
	T - 1-29	40
025030133	V - 76	60
	V - 95	60
025030232	K - 1-16	18
	K - 1-3	18
	M - 1-31	28
	T - 1-25	40
	T - 1-40	40
	T - 25-86	52
	V - 105	60
	V - 149	62
	V - 17	58
	X - 4-1-6	66
	X - 7-10	70
025040132	T - 26-16	54
	N - 4	30
	T - 1-15	40
	T - 29-8	54
	T - 49	44
	U - 1-27	56
	V - 102	60
	V - 7	58
	W - 4-7	64
	K - 1-13	18
	K - 1-20	18
025040232	L - 1-55	22
	M - 1-24	28
	Q - 4	32
	R - 42	34
	S - 24	38
	U - 1-16	56
	U - 1-21	56
	L - 1-26	20
	L - 1-71	22
	L - 2-8	24
	T - 1-44	40
T - 1-51	40	
025050232	T - 1-66	42
	T - 1-81	42
	T - 12-33	46
	T - 12-43	46
	T - 12-68	48
	T - 12-71	48
	T - 16	48
	T - 19	48

CODE	REF.NO.	PAGE
025050232	T - 25-92	52
	T - 31	54
	V - 21	58
	V - 35	58
	V - 4	58
025050332	Z2 - 20-2-2	72
025060232	L - 1-62	22
	L - 1-67	22
	L - 2-50	24
	R - 3	34
	T - 1-19	40
	T - 1-60	42
	T - 1-77	42
	T - 12-40	46
	T - 25-49	50
	T - 4	42
	V - 38	58
	V - 46	58
	V - 56	58
	V - 60	58
025060336	T - 65	54
	V - 117	60
025080232	L - 1-30	20
	L - 1-34	20
	L - 1-51	20
	L - 2-13	24
	L - 2-18	24
	L - 2-23	24
	L - 2-3	24
	L - 2-33	24
	L - 2-37	24
	T - 12-13	46
	T - 12-19	46
	T - 25-14	50
	T - 25-3	50
	T - 25-7	50
	U - 1-6	56
	V - 71	60
	X - 7-3	70
025100232	L - 1-41	20
	L - 2-44	24
025680132	G - 35	10
025680232	Z2 - 20-2-4	72
025710232	G - 14	10
	H - 26	12
025750132	Z2 - 20-2-6	72
028030242	M - 1-5	28
	N - 1-11	30
	N - 1-5	30
	N - 1-8	30
	T - 1-28	40
	T - 12-50	46
	V - 77	60
	V - 96	60
	K - 1-10	18
	K - 1-17	18
	K - 1-4	18
	N - 9-11	30
	T - 1-24	40
	T - 1-39	40
	T - 12-81	48
T - 25-44	50	
T - 25-87	52	
T - 26-22	54	
T - 26-26	54	
T - 26-4	54	
T - 26-6	54	

CODE	REF.NO.	PAGE	
028030243	T - 37	54	
	V - 150	62	
	V - 18	58	
	X - 6-1-10	68	
	X - 6-1-8	68	
	X - 6-2-10	68	
	X - 6-2-8	68	
	X - 6-9	68	
	X - 7-9	70	
	028040242	L - 1-3	20
		L - 1-82	22
		N - 5	30
		T - 1-14	40
		T - 1-91	42
		T - 25-54	50
T - 25-60		52	
T - 25-71		52	
T - 25-74		52	
T - 26-15		54	
T - 29-5		54	
T - 42		44	
T - 48		44	
U - 1-28		56	
V - 103		60	
V - 52	58		
V - 66	58		
W - 4-6	64		
X - 4-1-9	66		
X - 4-3	66		
X - 6-4	68		
028040243	K - 1-21	18	
	L - 1-54	22	
	M - 1-25	28	
	Q - 5	32	
	S - 23	38	
	T - 25-46	50	
	U - 1-17	56	
	U - 1-22	56	
	X - 6-12	68	
	028050242	D - 5	6
		L - 1-17	20
		L - 1-25	20
		L - 1-47	20
		L - 1-70	22
		L - 1-74	22
L - 2-54		24	
L - 2-59		26	
L - 2-9		24	
N - 11		30	
R - 18		34	
R - 21		34	
R - 47		36	
T - 1-43		40	
T - 1-47		40	
T - 1-50	40		
T - 1-65	42		
T - 1-80	42		
T - 1-88	42		
T - 12-32	46		
T - 12-36	46		
T - 12-42	46		
T - 12-46	46		
T - 12-67	48		
T - 12-72	48		
T - 15	48		
T - 20	48		
T - 25-21	50		

CODE	REF.NO.	PAGE	
028050242	T - 25-24	50	
	T - 25-41	50	
	T - 25-89	52	
	T - 28	54	
	T - 32	54	
	T - 7	42	
	V - 22	58	
	V - 34	58	
	V - 5	58	
	F - 54	8	
	028050243	Z2 - 12-7-2	72
		028050246	L - 1-61
	028060242		L - 1-66
		L - 2-49	24
		R - 4	34
	T - 1-18	40	
	T - 1-59	42	
	T - 1-76	42	
	T - 1-94	42	
	T - 1-96	42	
	T - 12-39	46	
	T - 25-50	50	
	T - 25-65	52	
	T - 5	42	
	V - 118	60	
	V - 39	58	
	V - 47	58	
	V - 57	58	
	V - 61	58	
028060243	U - 1-8-3-1	56	
028080242	L - 1-29	20	
	L - 1-33	20	
	L - 1-50	20	
	L - 2-14	24	
	L - 2-19	24	
	L - 2-24	24	
	L - 2-32	24	
	L - 2-36	24	
	L - 2-4	24	
	T - 12-12	46	
	T - 12-18	46	
	T - 25-15	50	
	T - 25-4	50	
	T - 25-8	50	
	U - 1-7	56	
	V - 72	60	
	X - 7-4	70	
028100242	L - 2-45	24	
028100243	L - 1-42	20	
031452206	Z2 - 12-2-2	72	
032311306	M - 2	28	
034311302	V - 152	62	
	V - 79	60	
047301042	M - 1-17	28	
047301242	N - 1-13	30	
048020342	K - 1-7	18	
048030342	L - 1-6	20	
048040342	G - 31	10	
	T - 12-14	46	
048050342	L - 1-45	20	
	L - 2-56	24	
	V - 31	58	
048060342	L - 2-20	24	
	U - 1-31	56	
048070342	L - 1-10	20	
048120142	T - 1-33	40	
050501406	Z2 - 12-7-5	72	

CODE	REF.NO.	PAGE
050503006	Z2 - 12-7-4	72
	060660512	C - 1-16
	H - 85	14
	M - 1-15	28
060670612	H - 121	14
061020506	T - 12-63	48
062060806	V - 81	60
	Z2 - 12-2-1	72
062300416	T - 25-85	52
	T - 26-24	54
062300512	T - 26-21	54
062300605	M - 1-4	28
062300616	K - 1-15	18
	K - 1-9	18
	N - 9-10	30
	T - 1-23	40
	T - 1-38	40
	V - 148	62
	V - 16	58
062301606	T - 12-80	48
062302505	X - 7-8	70
062302506	T - 36	54
062304006	T - 25-43	50
062400616	K - 1-12	18
062400806	K - 1-19	18
	Q - 3	32
	S - 22	38
	U - 1-15	56
	U - 1-20	56
	X - 6-11	68
062400816	L - 1-53	20
	T - 26-7	54
062401006	M - 1-26	28
	R - 41	34
062501406	Z2 - 12-4-2	72
062670512	B - 27	2
	H - 102	14
	H - 15	12
	H - 21	12
	H - 23	12
	H - 83	14
	J - 4	16
062670712	F - 33	8
062670812	C - 1-11	4
	F - 24	8
	H - 3	12
062671012	F - 31	8
062680616	S - 19	38
062680812	A - 3	2
	H - 79	12
	J - 6	16
	Z2 - 20-2-3	72
062681612	P - 7	32
062711012	G - 29	10
	H - 11	12
	H - 25	12
	P - 2	32
062712012	T - 25-82	52
	Z2 - 20-2-1	72
062751612	F - 4	8
062761412	K - 1-25	18
062780812	D - 2	6
062782512	G - 3	10
072600480	E - 6-2	6
073010002	T - 1-8	40
	T - 25-38	50
073050002	L - 1-19	20

CODE	REF.NO.	PAGE
081030070	H - 27	12
082104190	V - 119	60
100064002	J - 2	16
100105005	C - 1-7-9	4
100136001	M - 1-22	28
100197002	G - 4	10
100250001	B - 7	2
100251001	B - 12	2
	E - 5-2	6
100260001	F - 12-1	8
	F - 47	8
100401001	M - 1-21	28
100463001	V - 127	60
100645003	P - 8	32
100666002	Z2 - 20-2-5	72
100887001	Z1 - 17	70
101073001	V - 92	60
101572101	Z2 - 4	72
101706001	B - 11	2
102731004	C - 1-4	4
104821001	H - 31	12
	H - 97	14
	V - 145	62
107030001	C - 1-2	4
107155001	H - 29	12
107780001	Z1 - 16	70
108254001	J - 1-3	16
108265001	J - 1-5	16
108266001	J - 7	16
108802001	H - 64	12
108960002	G - 26	10
	J - 10	16
110087001	V - 129	60
110161006	G - 13	10
110233001	T - 25-83	52
110563001	F - 20	8
	F - 6	8
111140002	T - 50	44
	W - 4-8	64
111191001	H - 96	14
111942001	M - 1-13	28
111943001	M - 1-14	28
112293001	H - 124	14
112525000	T - 1-73-2	42
112573101	B - 1	2
112576001	B - 13	2
112586001	B - 17	2
112588101	C - 1-1	4
112590001	C - 1-3	4
112594001	C - 2	4
112609001	C - 1-7-7	4
112658001	J - 8	16
112684001	E - 5-1	6
112700001	G - 27-1	10
112709001	J - 3	16
112712001	J - 1-8	16
112715001	J - 9	16
112716101	H - 9	12
112717001	H - 10	12
112728001	H - 56	12
112734001	H - 38	12
112735000	H - 58	12
112736000	H - 61	12
112739001	H - 14	12
112751003	F - 35	8
112753001	H - 40	12
112758001	H - 95	14

CODE	REF.NO.	PAGE
113024000	B - 25	2
113050001	F - 44	8
113362001	H - 41	12
113431002	P - 3	32
113653000	H - 59	12
114447002	C - 1-7-13	4
114483002	Z2 - 19	72
114486002	Z2 - 18	72
114693001	H - 57	12
114859001	U - 1-9	56
114909000	V - 24	58
114941001	J - 11	16
	Z2 - 9	72
114967001	V - 128	60
115157001	Z1 - 9	70
115249001	H - 42	12
115585001	F - 48	8
116795000	H - 125	14
117466000	Z2 - 6	72
117934001	L - 2-46	24
118064001	Z1 - 11	70
118320001	J - 1-7	16
118837001	Z2 - 3	72
119706001	U - 1-2	56
119707002	U - 1-3	56
119708001	U - 1-4	56
119709002	U - 1-1-2	56
122991001	Z1 - 1	70
	Z2 - 1	72
126863001	Z2 - 12-10	72
131007001	E - 5-3	6
131226001	G - 40	10
133172003	V - 155	62
133792101	U - 1-8-3	56
140553102	W - 4-3	64
140620001	F - 52	8
140682001	L - 1-72-3	22
	L - 2-57-3	26
	R - 15-3	34
	R - 19-3	34
	R - 45-3	36
	X - 7-7-3	70
140890001	H - 30	12
141032000	Z1 - 2	70
141256001	Z2 - 15	72
141598001	T - 12-74	48
142002001	Z1 - 14	70
142027001	V - 126	60
142205001	Z1 - 18	70
142268001	H - 20	12
142274001	H - 32	12
142443001	Z2 - 2	72
142721001	Z1 - 12	70
143489001	L - 1-80-5	22
143531000	X - 4-1-7-1	66
143549000	V - 112-3	60
143625001	F - 19	8
	F - 5	8
143626000	F - 7	8
143627000	F - 9	8
143637001	F - 21-1	8
143641001	F - 37	8
143642101	F - 38	8
143646000	F - 21-2	8
143676000	H - 126	14
143679000	H - 120	14
143936000	H - 123	14

CODE	REF.NO.	PAGE
144504001	K - 1-23-3	18
144680001	J - 1-1	16
144682001	J - 1-4	16
144685001	J - 1-15	16
144686001	J - 1-16	16
144687001	J - 1-17	16
144688001	J - 1-18	16
144689001	J - 1-19	16
145446001	J - 1-11	16
	M - 1-20	28
145571101	M - 1-19	28
145646016	A - 4-1	2
	Z2 - 7	72
145646018	A - 4-2	2
146080000	X - 4-1-7-2	66
146141001	B - 8	2
146197001	M - 1-23	28
146253000	H - 92	14
146427001	W - 1-2	64
	W - 2-2	64
146536001	H - 101	14
146581001	F - 46	8
147843001	U - 1-30	56
147926000	L - 1-80-2	22
147933001	L - 1-58	22
148005001	G - 12	10
148539101	F - 40	8
148555001	T - 1-85	42
148762001	H - 37	12
148821001	E - 6-3	6
	E - 9	6
149066001	X - 4-1-7-3	66
149069101	X - 4-1-3	66
149070001	X - 4-1-4	66
149320001	Q - 6	32
149342001	L - 1-31	20
	L - 2-34	24
149487001	L - 1-39	20
	L - 2-42	24
149488001	L - 1-40	20
	L - 2-43	24
149547000	X - 4-5	66
149566002	J - 1-14	16
149604001	C - 1-7-1	4
149605001	C - 1-7-2	4
149606001	C - 1-7-4	4
149607001	C - 1-7-5	4
149608001	C - 1-7-6	4
149609001	C - 1-7-8	4
149610001	C - 1-7-10	4
149611101	C - 1-7-11	4
149612101	C - 1-7-12	4
149613001	C - 1-8	4
149621001	C - 1-13	4
149622001	C - 1-14	4
149623001	C - 1-15	4
149624001	C - 1-17	4
149625001	C - 1-18	4
149626001	H - 84	14
149796001	R - 5	34
149809000	L - 1-83	22
	R - 37	34
	S - 26	38
	V - 144	62
149820000	B - 6	2
149821101	B - 9	2
149827001	C - 1-7-3	4

CODE	REF.NO.	PAGE
149831101	W - 1-3	64
	W - 2-3	64
149834000	H - 34	12
149863001	D - 12	6
149864001	D - 13	6
149865001	D - 15	6
150106002	Z2 - 12-4	72
150172002	Z2 - 12-3	72
150173002	Z2 - 12-4-1	72
150174000	Z2 - 12-5	72
150179002	Z2 - 12-7-1	72
150180000	Z2 - 12-8	72
150182000	Z2 - 12-9	72
150189002	Z2 - 12-1	72
150191001	V - 82-3	60
150206002	V - 82-2	60
150332001	Z1 - 21	70
150335001	Z1 - 10	70
150349001	V - 136	60
150374000	H - 55	12
150756000	V - 153	62
150816001	C - 1-9	4
150967101	G - 11	10
151027001	G - 23-1-1-1	10
151029001	G - 23-2-4	10
151030001	G - 23-2-5	10
151035001	G - 23-2-2	10
151163001	L - 2-22	24
151604001	F - 1-1	8
151605002	V - 114	60
151927001	H - 35	12
152356301	M - 1-1	28
152357101	M - 1-2	28
152358001	M - 1-6	28
152361001	M - 1-11	28
152362001	M - 1-12	28
152363001	M - 1-16	28
152364001	M - 1-18	28
152645001	M - 1-29	28
152651301	M - 1	28
152974001	H - 128	14
	H - 72	12
152997001	F - 49	8
153012101	C - 3	4
153015001	F - 1	8
153019001	F - 36	8
	Z2 - 16	72
153020001	F - 39	8
153024000	H - 122	14
153242000	Z1 - 4	70
153252000	R - 6	34
153274001	L - 1-72-4	22
	L - 2-57-4	26
	R - 15-4	34
	R - 19-4	34
	R - 45-4	36
153920001	H - 71	12
154024001	M - 1-8	28
154092001	M - 1-9	28
154125001	Z1 - 13	70
154560001	K - 1-23-4	18
154702001	Z2 - 11	72
155055001	X - 4-2	66
155478001	G - 23-2-1	10
155479001	G - 23-2-3	10
155491001	J - 1-2	16
156070002	H - 75	12

CODE	REF.NO.	PAGE
156096000	X - 6-7-4	68
156292001	T - 1-99	42
156557001	G - 42	10
158115001	B - 18	2
	E - 7-1	6
158597001	M - 1-32	28
158769001	J - 1-9	16
159150000	A - 9	2
159384001	Z2 - 10	72
159386001	V - 113	60
159436001	G - 32	10
159732001	D - 7	6
	X - 6-1-4	68
	X - 6-2-4	68
159805001	J - 1-12	16
159812001	V - 112-1	60
180157001	B - 14	2
183377001	K - 1-23	18
183387001	U - 1-1-1	56
183400001	Z2 - 17	72
183480001	Z2 - 20	72
183677001	F - 12	8
183699001	F - 21	8
219225000	Z1 - 5	70
230157001	P - 1	32
522990001	X - 4-1-5	66
552851001	M - 1-28-2	28
552907000	R - 40	34
554482000	R - 38	34

**brother**

**ブラザー工業株式会社**









〒467 名古屋市瑞穂区妙音通 1-32  
TEL (052) 824-2392代

**BROTHER INDUSTRIES, LTD. NAGOYA, JAPAN**

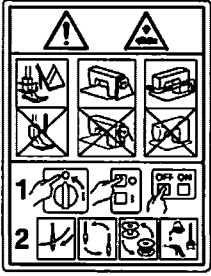
151-612  
198612-001  
1989, 09

Printed in Japan/Gedruckt in Japan/Imprimé au Japan/Impreso en Japón

Wa. 警告ラベル / Warning labels











警告ラベル / Warning labels	品名 / Name of parts	Size(mm)	Code
	ラベル感電6ヶ国 Label electrical shock 36 X 150	36 X 150	SA9725-001
	ラベル感電 25 X 28 Label electrical shock 25 X 28	L=28.4	SA9914-001
	操作注意ラベル Label caution	56 X 43	SA9826-001
	ワーニングマーク Injury mark	L=16	SA9957-001
	ワーニングマーク Injury mark	L=25	SA9957-002
	アースマーク Label, grounding	φ 12	S37060-001
	PE マーク Label, PE	7.5 X 12.5	S37059-001
	マークチュウイ 30 X 40 Mark attention 30 X40	30 X 40	SA4224-001









Wa. 警告ラベル / Warning labels

警告ラベル / Warning labels	品名 / Name of parts	Size(mm)	Code
<div data-bbox="337 254 526 1066" style="border: 1px solid black; padding: 5px;"> <p><b>brother</b>                      ミシン用潤滑油                      Lubricating Oil for Machining</p> <p><b>▲ 注意</b></p> <p>目に入ったり皮膚につくと、炎症を起こすことがある。                      保護めがね、手袋を使うこと。</p> <p>飲み込むと、下痢、嘔吐する。                      飲み込まないこと。</p> <p>●子供の手の届かない所に置いてください。                      ●目に入った場合は、清潔な水で15分間洗浄し、医師の診断を受けてください。                      ●皮膚に付けた場合は、水と石けんで十分に洗ってください。                      ●飲み込んだ場合は、無理に吐かせずに、直ちに医師の診断を受けてください。</p> <p>第4類 第3石油類                      危険等級III 火気厳禁</p> <p><b>▲ CAUTION</b></p> <p>Lubricating oil may cause inflammation to eye and skin.                      Wear protective glasses and gloves.</p> <p>Swallowing oil can cause diarrhoea and vomiting.                      Do not swallow.</p> <p>Keep away from children.  <b>FIRST AID</b>                      Eye contact:                      -Rinse with plenty of cold water.                      -Seek medical help.                      Skin contact:                      -Wash with soap and water.                      If swallowed:                      -Seek medical help immediately.                      -Do not induce vomiting.</p> </div>	<p>オイル警告ラベル                      Oil warning label</p>	<p>148 X 34</p>	<p>SB1505-001</p>

Sp. 仕様別部品一覧表 / Different parts list

品名 Part name	仕様 Spec.	中厚物 Medium-weight materials	厚物 Heavy-weight materials	シートベルト Seatbelt
(J-57) 針穴板 Needle hole plate 		(φ2.2) SA5221-001	(φ2.4) SA3336-101	(φ3.0) SA5222-101
(J-54) 固定刃 Fixed knife 		SA7944-101 < FL >		SB0623-001 < FLL >
(E-38) ボビンケース組 Bobbin case assy 		S59221-301 < LC >		S59222-301 < LD >
(E-39) ボビンケース 調子ばね Tension spring 		S48664-001 < AN >		S16075-101 < B >
(E-40) ボビンケース ばねねじ Screw 		S16492-101		
(E-41) 空転防止ばね Anti-spin spring 		S15667-001		
(E-42) (Z-9) ボビン Bobbin 		S44633-001 < LAN >		S15666-001 < LB >
(E-34) ドライバー Driver 		SA6448-301 < E >		S55215-101 < HR >
(E-37) 中がま箱組 Shuttle hook assy, w/box 		SA2173-301 < LF >	SA8197-101 < LH >	SA8197-101 < LH >
(E-36) 大がま Shuttle race base 		152682-201 < A >	152686-201 < B >	152686-201 < B >

Sp. 仕様別部品一覧表 / Different parts list

品名 Part name	仕様 Spec.	中厚物 Medium-weight materials	厚物 Heavy-weight materials	シートベルト Seatbelt
(G-25) 糸調子ばね Tension spring		104525-101	107606-101	107606-101
(G-7) 糸取りばね Thread take-up spring		SA9058-001	144588-401	144588-401
(G-23) 副調子ばね Sub tension spring		SA4146-101		SA3416-101
(T1-30) 調子ばね上ザガネ Washer		—		S20681-000
(G-20) 針棒系案内 Needle bar thread guide	 A  B	SA3257-101 < A >		SA4815-201 < B >
(D1-57) 押え足 Presser foot		S42843-001 < A >		S42844-001 < B >

Ga. ゲージ部品一覧表 / Gauge parts list

押え足 / Presser foot			
A / S42843-001 *	B / S42844-001	C / S42845-001	D / S42846-001
E / S42847-001	F / 157237-001	G / 158592-001	J / S42848-001
A-CUT / S40214-001	B-L / S49448-001	XA / S42849-101	H / SA4811-001

針穴板 / Needle hole plate			
2.4 C0.4 / SA3336-101 *	2.2 / SA5221-001 *	3.0 C1.5 / SA5222-101 *	1.6 / SA7191-001

\* 印の部品は、標準部品です。

The \* symbol is for Standard parts.

CODE	REF.NO	Page	CODE	REF.NO	Page	CODE	REF.NO	Page	CODE	REF.NO	Page
004300513	A -22	2	016061031	D2 -36	20	021060306	J -23	32	060400516	K -21	36
012060536	B -37	4		D3 -14	22	021080206	M1 -12	40		L -17	38
	C3 -11	10	017061213	D1 -12	18	021300103	A -26	2	062060816	F -30	26
	C3 -23	10	017061612	D1 -44	18	021400106	C4 -54	12	062061003	Z -33	62
	C4 -17	12	017065002	D1 -45	18		C5 -48	14	062061016	A -19	2
	C4 -33	12	017081606	T1 -22	54	021400216	C1 -40	6		F -4	26
	C5 -23	14	017400802	J -5	32		C2 -4	8		H -37	30
	D1 -55	18		L -2	38		C4 -26	12	062061603	Z -29	62
	E -6	24	017401415	L -5	38	021400306	G -18	28	062300416	C1 -49	6
012060636	B -24	4	017501216	T3 -25	58		L -6	38		D1 -20	18
	C1 -18	6	017501616	C4 -49	12	021500203	Z -21	62		J -55	34
	C1 -22	6		C5 -41	14		Z -31	62		J -64	34
	C1 -33	6	018061236	D2 -58	20	021500216	C4 -45	12	062300506	A -25	2
	C4 -4	12		D3 -27	22		C5 -34	14	062300616	E -20	24
	C4 -13	12	018061636	J -43	32		C5 -39	14		K -7	36
	C4 -22	12	018063036	C1 -19	6		T3 -26	58		T4 -5	60
	C4 -29	12	018064031	Z -54	62	025040136	A -32	2	062300816	P -6	46
	C5 -4	14	018066036	Z -47	62	025040236	C6 -12	16	062350616	H -8	30
	C5 -6	14		Z -49	62	025060236	Z -64	64	062400416	D2 -6	20
	C5 -19	14		Z -63	64		Z -70	64	062400616	C3 -5	10
	D1 -14	18	018300636	Z -37	62	025080336	M1 -10	40		D1 -6	18
	D1 -24	18	018300836	T3 -24	58	025350132	T3 -17	58		D2 -29	20
	D1 -30	18	018301036	T3 -10	58	026030233	Z -36	62		D2 -54	20
	D1 -36	18	018301236	T3 -9	58	026040136	F -33	26		D2 -56	20
	D2 -11	20	018301436	C6 -3	16		Z -41	62		D3 -11	22
	D2 -14	20	018302036	T1 -11	54	026040236	J -7	32		D3 -26	22
	D2 -25	20	018400636	D2 -39	20		L -4	38		F -6	26
	D2 -33	20		D3 -17	22	028030246	J -62	34		F -13	26
	D2 -37	20		F -11	26	028040246	C1 -39	6		F -32	26
	D2 -41	20		T3 -39	58		C5 -16	14	062400816	B -22	4
	D2 -57	20	018400836	C3 -21	10		J -6	32		B -33	4
	D3 -7	22		C5 -15	14		L -3	38		C1 -13	6
	D3 -15	22		D1 -48	18	028050243	Z -20	62	062401016	A -7	2
	D3 -19	22		D2 -3	20	028050246	C4 -37	12		A -31	2
	D3 -32	22		K -9	36		C4 -51	12	062401216	C1 -50	6
	D3 -33	22		T2 -3	56		C5 -43	14	062500616	G -5	28
	E -9	24		T3 -23	58		N -11	44		H -30	30
	E -12	24		Z -40	62	028060246	Z -66	64		T4 -8	60
	E -33	24	018401036	C3 -9	10	028080246	M1 -11	40	062500816	L -10	38
	G -27	28		C3 -14	10	028350242	T3 -34	58	062501216	A -28	2
	J -37	32		C3 -26	10	032422003	N -19	44		Z -3	62
	Z -45	62		D2 -23	20	037301215	Z -6	62	062670412	G -30	28
012400436	D1 -25	18		D3 -5	22	047402042	B -45	4	062670512	T3 -32	58
	D1 -31	18		F -48	26	048030342	K -19	36	070696800	D2 -44	20
	H -17	30	018401236	H -13	30	048040142	C4 -9	12		D2 -49	20
	H -24	30	018401636	B -27	4	048040342	J -20	32		D3 -22	22
	J -9	32	018500836	C4 -35	12		K -12	36	081003670	E -48	24
012400636	C1 -4	6	018501036	C1 -3	6		L -13	38	085311016	Q -11	48
012500536	B -21	4		C3 -15	10	048050142	C5 -8	14	0A4300806	K -26	36
	B -34	4		C3 -27	10	048050342	H -10	30	0A4400806	Q -8	48
	B -35	4		D2 -21	20		H -19	30		Q -9	48
	D2 -46	20		D3 -3	22	048060142	C5 -11	14	0A5301605	P -8	46
	D2 -51	20	018501232	E -35	24	048060342	Z -62	62	0A5401006	F -38	26
	D3 -24	22	018501636	B -3	4	048080142	C4 -14	12		F -44	26
	E -44	24		B -36	4		C4 -30	12		F -45	26
	H -3	30	018503036	N -12	44		C5 -20	14		F -50	26
	H -36	30	021060106	D1 -10	18		D1 -29	18		N -22	44
	J -42	32		D1 -46	18	048080342	D2 -13	20		P -4	46
012501031	C4 -44	12		J -31	32	048100142	C1 -26	6		P -13	46
	C5 -33	14		Z -50	62		C4 -6	12		T1 -26	54
	C5 -38	14		Z -55	62		D2 -28	20		T2 -8	56
014060632	Z -30	62		Z -67	64		D3 -10	22		T4 -10	60
016061031	D2 -32	20	021060306	D1 -41	18	048280142	B -43	4	0B0452006	Q -13	48

索引 / Index

CODE	REF.NO	Page	CODE	REF.NO	Page	CODE	REF.NO	Page	CODE	REF.NO	Page
100136001	G -22	28	150182000	Z -15	62	J00353001	M1 -6	40	S23651001	B -8	4
100242003	T3 -18	58	150183000	Z -24	62	J04417001	M1 -3	40		B -14	4
100360003	J -58	34	151439102	D1 -59	18	S00470000	P -15	46		B -17	4
100401022	H -33	30	152682201	Sp	67	S00480000	T1 -25	54		B -39	4
100402004	G -12	28	152684101	E -18	24	S00705001	J -52	34		D1 -5	18
100645004	C5 -17	14	152686201	Sp	67	S02429201	E -15	24		D1 -15	18
102630021	D2 -9	20	152744001	D2 -8	20	S02652021	J -11	32		E -8	24
102707002	L -7	38	152881101	G -26	28	S03677001	K -23	36		J -2	32
104449001	A -4	2	152883000	G -28	28	S03803000	T3 -41	58		J -25	32
	A -36	2	152884001	G -29	28	S03816001	M1 -17	40	S23849101	C5 -25	14
104450101	A -39	2	152936001	H -6	30		M2 -3	42	S25235001	B -15	4
104525101	Sp	68	152937001	H -7	30	S04109001	Z -17	62	S25279101	K -14	36
104567101	F -19	26	153274001	N -9	44	S04516001	T3 -51	58	S25310101	D1 -37	18
104821001	A -5	2	154235001	T3 -12	58	S04897000	T2 -5	56		J -59	34
	D3 -29	22	154236001	T3 -13	58	S04905000	T3 -38	58	S25454021	K -13	36
107606101	Sp	68	154237101	T3 -16	58	S05665001	T3 -11	58	S25456021	K -4	36
108802001	E -46	24	154252001	T3 -30	58	S06706001	Z -71	64	S25475101	J -30	32
109714000	Z -7	62	154253001	T3 -31	58	S07350002	A -11	2	S28741000	T3 -42	58
109763022	D2 -45	20	154256101	T3 -35	58	S07459100	F -16	26	S31032002	G -9	28
	D2 -50	20	154291101	T3 -53	58	S08003000	F -53	26		H -34	30
	D3 -23	22	154297001	T3 -52	58		F -58	26	S32465101	J -22	32
110367001	B -18	4	154467001	Z -5	62	S09043000	F -24	26		J -34	32
	C4 -15	12	154596000	J -29	32	S09228000	N -6	44	S34533001	T1 -13	54
	C4 -31	12	154599000	J -10	32	S10112101	D1 -52	18	S34534101	T1 -14	54
	C5 -21	14		L -8	38	S10243000	T2 -7	56	S34706000	T1 -10	54
110735022	K -18	36	155510001	T1 -15	54	S10268001	H -27	30	S35079000	D2 -35	20
111466121	D1 -56	18	155559021	H -9	30	S10438001	H -18	30	S35183000	C4 -3	12
114483002	Z -10	62		H -25	30	S10470201	K -20	36		C5 -3	14
114486002	Z -8	62	156492101	T3 -54	58	S10542001	T3 -50	58	S36475000	A -12	2
117291002	T3 -29	58	157237001	Ga	69	S12150000	T1 -12	54	S37037001	Z -32	62
117608001	A -2	2	158592001	Ga	69	S12165000	T3 -37	58	S37059001	M1 -8	40
118208001	D2 -15	20	159150000	A -34	2	S12441001	G -24	27		Wa	65
118550001	D3 -30	22	159163000	A -33	2		H -35	30	S37060001	A -41	2
120265002	A -10	2		D3 -28	22	S12633309	T3 -2	58		M1 -7	40
120448001	H -23	30	159805001	G -10	28	S12634109	T3 -3	58		Wa	65
128843201	Z -28	62	200190001	M1 -18	40	S12635009	T3 -4	58	S38265000	F -51	26
141362001	D1 -34	18		M2 -4	42	S12636001	T3 -5	58	S38266000	F -42	26
142211001	B -25	4		Q -14	48	S12637009	T3 -19	58	S38713100	B -32	4
142274101	F -52	26	213650001	Z -48	62	S12641009	T3 -6	58	S39116100	N -3	44
142990001	Z -25	62		Z -65	64	S12642009	T3 -21	58		T1 -3	54
142997001	Z -18	62	218859001	P -16	46	S12643001	T3 -28	58		T1 -7	54
144458001	B -29	4	220681001	Q -10	48	S12644001	T3 -49	58	S40214001	Ga	69
144504001	T1 -20	54	228475000	N -23	44	S12699000	G -14	28	S40574409	Z -13	62
144588401	Sp	68	231071001	J -26	32	S13399001	D1 -58	18	S41205001	K -3	36
145087001	T3 -14	58	402887001	E -19	24	S15031010	T1 -23	54	S41206001	K -2	36
145446001	G -11	28	525567000	F -37	26		T2 -4	56	S42446001	A -16	2
	G -16	28		P -1	46	S15666001	Sp	67		C1 -31	6
145446002	H -32	30	525664000	F -39	26	S15667001	Sp	67		C2 -10	8
145465001	B -23	4		N -21	44	S16075101	Sp	67		C3 -17	10
145547021	F -31	26	525907000	T1 -27	54	S16492101	Sp	67		Z -58	62
146058001	T1 -18	54		T2 -9	56	S17974101	Z -59	62	S42843001	Sp	68
146059001	T1 -17	54	552907000	T3 -48	58	S17975200	Z -60	62		Ga	69
146060000	T1 -16	54	625010000	T4 -9	60	S18027201	T2 -2	56	S42844001	Sp	68
146206009	T1 -19	54	BMP3010-0000000-2ST1			S18415101	T3 -27	58		Ga	69
146288021	K -22	36		M2 -5+	42	S20164001	A -37	2	S42845001	Ga	69
148847001	N -20	44	BMP3010-0000000-3ST4			S20356001	D2 -12	20	S42846001	Ga	69
149097000	K -16	36		M2 -6+	42		D2 -52	20	S42847001	Ga	69
149287000	P -3	46	BMP3010-0000000-4ST4			S20681000	Sp	68	S42848001	Ga	69
149547000	F -36	26		M2 -6+	42	S23337001	A -35	2	S42849101	Ga	69
	P -2	46	BMP3010-0000001-3S00			S23418001	C6 -9	16	S44010001	A -38	2
149796001	N -24	44		M2 -2+	42		C6 -11	16	S44485101	Z -35	62
149831101	T3 -15	58	BMP3010-0000001-3ST4			S23418002	H -15	30	S44633001	Sp	67
150179002	Z -19	62		M2 -6+	42	S23651001	B -11	4	S46903001	J -19	32

CODE	REF.NO	Page	CODE	REF.NO	Page	CODE	REF.NO	Page	CODE	REF.NO	Page
S47307001	E - 32	24	SA3242001	E - 29	24	SA4175001	B - 4	4	SA4744001	D2 - 26	20
S48140002	T1 - 29	54	SA3244001	F - 1	26	SA4177001	B - 10	4		D3 - 8	22
S48189000	F - 26	26	SA3246001	F - 27	26	SA4178001	B - 13	4	SA4745001	D2 - 31	20
S48664001	Sp	67	SA3250001	G - 1	28	SA4179001	B - 6	4		D3 - 13	22
S49448001	Ga	69	SA3254001	G - 6	28	SA4180001	B - 7	4	SA4746001	D2 - 34	20
S49957000	F - 34	26	SA3255001	G - 8	28	SA4197101	C3 - 22	10	SA4747001	D2 - 38	20
S49982000	F - 25	26	SA3256001	G - 15	28	SA4199001	E - 16	24		D3 - 16	22
S49992000	F - 20	26	SA3257101	Sp	68	SA4224001	C3 - 16	10	SA4748101	D2 - 40	20
S50359001	F - 49	26	SA3258001	G - 21	28		D2 - 59	20		D3 - 18	22
S50547000	F - 61	26	SA3264101	A - 23	2		D3 - 34	22	SA4750001	D2 - 47	20
S50557000	E - 25	24	SA3274101	E - 31	24		Wa	65	SA4752001	D2 - 53	20
S51282101	Z - 16	62	SA3280001	F - 28	26	SA4302001	D1 - 9	18	SA4753001	D2 - 55	20
S51283001	Z - 14	62	SA3283101	E - 43	24	SA4333001	G - 2	28		D3 - 25	22
S53982000	T1 - 4	54	SA3290001	H - 2	30	SA4354001	J - 47	32	SA4757101	D3 - 31	22
S55215101	Sp	67	SA3291001	H - 4	30	SA4518001	J - 50	34	SA4759001	D1 - 1	18
S55479001	C6 - 6	16	SA3293001	H - 11	30	SA4519001	J - 51	34	SA4760001	D1 - 2	18
	Z - 69	64	SA3294001	H - 14	30	SA4545001	J - 36	32	SA4761001	D1 - 7	18
S55482001	C4 - 39	12	SA3295001	H - 16	30	SA4574001	S - 8	52	SA4762001	D1 - 8	18
	C5 - 27	14	SA3296001	H - 21	30	SA4588001	J - 41	32	SA4763001	D1 - 3	18
S55484001	C2 - 9	8	SA3297001	H - 22	30	SA4594001	A - 1	2	SA4764001	D1 - 11	18
	C3 - 2	10	SA3298001	H - 28	30	SA4596001	A - 3	2	SA4765001	D1 - 13	18
	J - 13	32	SA3299001	H - 29	30	SA4600002	A - 17	2	SA4766001	D1 - 16	18
	T3 - 45	58	SA3306001	A - 9	2	SA4601001	A - 18	2	SA4767001	D1 - 17	18
	T3 - 46	58		J - 15	32	SA4603102	A - 20	2	SA4768001	D1 - 18	18
S55485001	C3 - 28	10	SA3307001	J - 8	32	SA4604101	A - 8	2	SA4769101	D1 - 19	18
	C4 - 43	12	SA3309201	J - 16	32	SA4605001	A - 15	2	SA4770001	D1 - 21	18
	C4 - 52	12	SA3310001	J - 17	32	SA4606201	B - 1	4	SA4771001	D1 - 27	18
	C5 - 32	14	SA3311001	J - 18	32	SA4608101	B - 12	4	SA4772001	D1 - 22	18
	C5 - 37	14	SA3312201	J - 27	32	SA4609101	B - 16	4	SA4773001	D1 - 23	18
	C5 - 46	14	SA3313101	J - 28	32	SA4622001	B - 28	4	SA4775101	D1 - 38	18
	K - 25	36	SA3321001	J - 39	32	SA4647001	C1 - 15	6	SA4777001	D1 - 26	18
	T3 - 47	58	SA3334001	J - 53	34		C1 - 23	6	SA4778001	D1 - 47	18
S59221301	Sp	67	SA3336101	Sp	67		D2 - 27	20	SA4779101	D1 - 32	18
S59222301	Sp	67		Ga	69		D3 - 9	22	SA4780001	D1 - 35	18
S59886001	E - 22	24	SA3347001	L - 12	38	SA4666001	B - 30	4	SA4781001	D1 - 33	18
S59894001	T3 - 7	58	SA3348001	L - 15	38	SA4676201	C2 - 5	8	SA4782001	E - 4	24
SA1174002	D1 - 49	18	SA3384101	Z - 44	62	SA4677101	C2 - 2	8	SA4783101	E - 10	24
SA1175002	D1 - 50	18	SA3385001	Z - 46	62	SA4687101	C4 - 5	12	SA4785101	F - 2	26
SA1394101	F - 40	26	SA3392001	Z - 43	62	SA4688001	C4 - 7	12	SA4786101	F - 8	26
SA1984001	H - 12	30	SA3395001	Z - 42	62	SA4689001	C4 - 8	12	SA4787001	F - 5	26
SA1988001	H - 26	30	SA3416101	T1 - 28	54	SA4692001	C4 - 12	12	SA4788001	F - 12	26
SA2161001	D1 - 28	18		Sp	68		C4 - 28	12	SA4789101	F - 29	26
SA2173301	Sp	67	SA3441001	D3 - 21	22		C5 - 18	14	SA4791101	F - 35	26
SA2195001	D1 - 54	18	SA3441101	D2 - 43	20	SA4693001	C4 - 19	12	SA4796001	H - 20	30
SA2287001	K - 15	36		D2 - 48	20	SA4706101	C4 - 41	12	SA4797101	B - 38	4
SA2864001	F - 22	26	SA3499001	B - 2	4		C5 - 30	14	SA4798001	J - 3	32
SA2929001	F - 43	26	SA3503201	F - 9	26	SA4709001	C4 - 46	12	SA4799001	J - 14	32
SA2958001	B - 20	4	SA3504201	F - 10	26		C5 - 35	14	SA4806101	K - 6	36
SA2972001	C1 - 20	6	SA3528001	B - 26	4		C5 - 40	14	SA4811001	Ga	69
SA3206001	B - 5	4	SA3538001	C1 - 37	6	SA4712001	C5 - 28	14	SA4815201	Sp	68
	B - 9	4		C1 - 52	6	SA4714001	C5 - 29	14	SA4816001	T4 - 2	60
SA3224001	B - 31	4		C2 - 12	8	SA4717001	C5 - 5	14	SA4817001	T4 - 3	60
SA3226001	E - 1	24		J - 60	34	SA4719001	C5 - 7	14	SA4818001	T4 - 4	60
SA3227001	D1 - 42	18	SA3707101	C3 - 10	10	SA4720001	C5 - 9	14	SA4819001	T4 - 6	60
	E - 2	24	SA4025001	F - 21	26	SA4721001	C5 - 10	14	SA4837101	Q - 6	48
SA3228101	E - 3	24	SA4028001	F - 60	26	SA4736001	D2 - 7	20	SA4841101	Q - 7	48
SA3231001	C4 - 16	12	SA4131001	J - 1	32	SA4737001	D2 - 10	20	SA4846002	Z - 52	62
	C4 - 32	12	SA4143001	G - 13	28	SA4738001	D2 - 16	20	SA4853001	D1 - 39	18
	C5 - 22	14	SA4146101	Sp	68	SA4739001	D2 - 18	20	SA4863001	C5 - 24	14
	E - 5	24	SA4171001	H - 5	30	SA4741301	D2 - 19	20	SA4864001	C4 - 38	12
SA3233101	E - 7	24	SA4172001	B - 4	4		D3 - 1	22		C5 - 26	14
SA3238301	E - 47	24	SA4173001	B - 4	4	SA4743001	D2 - 24	20	SA5135101	J - 4	32
SA3241001	E - 17	24	SA4174001	B - 4	4		D3 - 6	22	SA5164101	S - 1	52

## 索引 / Index

CODE	REF.NO	Page	CODE	REF.NO	Page	CODE	REF.NO	Page	CODE	REF.NO	Page
SA5165001	S - 2	52	SA6599001	C6 - 14	16	SA9957002	A - 43	2	SB4277001	D3 - 4	22
SA5166001	S - 3	52	SA6600001	C6 - 15	16		Wa	65	SB4281001	C1 - 29	6
SA5167001	S - 7	52	SA6603001	C6 - 10	16	SB0445001	N - 8	44	SB4282001	C1 - 21	6
SA5172001	S - 5	52	SA6604001	C6 - 8	16	SB0468001	Z - 51	62	SB4296001	P - 7	46
SA5191001	N - 13	44	SA6607001	Z - 22	62	SB0553001	Q - 5	48	SB4297101	K - 1	36
SA5193101	T4 - 1	60		Z - 23	62	SB0556001	Z - 39	62	SB4334001	C3 - 8	10
SA5194001	T4 - 7	60	SA6609001	Z - 26	62	SB0557101	Z - 34	62	SB4335001	C1 - 32	6
SA5210001	P - 10	46	SA6615001	Z - 27	62	SB0559101	Z - 38	62	SB4337001	C1 - 30	6
SA5213001	K - 24	36	SA6616001	T3 - 44	58	SB0566001	Q - 12	48	SB4338001	C1 - 27	6
SA5219001	K - 17	36	SA6617001	T3 - 43	58	SB0623001	Sp	67	SB4339001	C1 - 16	6
SA5221001	Sp	67	SA7139001	C6 - 5	16	SB0705101	D2 - 17	20	SB4340001	C1 - 17	6
	Ga	69	SA7140001	C6 - 1	16	SB0713001	J - 65	34	SB4341001	C1 - 12	6
SA5222101	Sp	67	SA7141001	C6 - 7	16	SB0752101	Q - 1	48	SB4342001	C3 - 4	10
	Ga	69	SA7155001	T1 - 24	54	SB0787001	L - 16	38	SB4343001	C3 - 3	10
SA5251001	Z - 53	62		T2 - 6	56	SB0910201	B - 47	4	SB4344101	C1 - 1	6
SA5281201	N - 1	44	SA7166101	T1 - 5	54	SB1038001	B - 42	4	SB4346001	C3 - 1	10
SA5282001	N - 5	44	SA7167101	T1 - 8	54	SB1039001	B - 41	4	SB4351001	C1 - 8	6
SA5283001	N - 4	44	SA7171001	T1 - 6	54	SB1040001	B - 48	4	SB4356001	C1 - 36	6
SA5286101	N - 10	44	SA7189101	T3 - 1	58	SB1041001	B - 46	4	SB4357001	C1 - 35	6
SA5289001	N - 2	44	SA7191001	Ga	69	SB1086001	G - 4	28	SB4358001	C1 - 43	6
SA5290001	T1 - 2	54	SA7193001	T3 - 22	58	SB1200101	P - 9	46	SB4359001	C1 - 44	6
SA5291101	C6 - 2	16	SA7197101	T1 - 9	54	SB1229001	M2 - 5+	42	SB4360001	C1 - 41	6
SA5294001	F - 7	26	SA7199001	T1 - 21	54	SB1253001	H - 31	30	SB4361001	C1 - 48	6
SA5300001	D1 - 51	18	SA7385001	C6 - 16	16	SB1277001	A - 6	2	SB4362001	C1 - 45	6
SA5301001	D1 - 53	18	SA7460001	T3 - 36	58	SB1505001	Z - 12	62	SB4363001	C1 - 46	6
SA5339101	F - 55	26	SA7500001	T1 - 1	54		Wa	66	SB4365101	C1 - 47	6
SA5415001	C6 - 17	16	SA7588001	N - 7	44	SB1543002	Z - 11	62	SB4366001	C1 - 34	6
SA5559101	T2 - 1	56	SA7704001	D1 - 4	18	SB1565001	R - 1	50	SB4367001	C4 - 11	12
SA5593001	C1 - 7	6	SA7944101	Sp	67	SB2097001	B - 44	4	SB4368001	C4 - 10	12
	D2 - 1	20	SA8057001	K - 11	36	SB2131001	C4 - 40	12	SB4369001	C5 - 14	14
SA5829001	C6 - 4	16	SA8197101	Sp	67	SB2356001	Z - 61	62	SB4370001	C5 - 13	14
SA6038001	R - 2	50	SA8560001	C2 - 3	8	SB2439001	J - 49	34	SB4371001	C5 - 12	14
SA6087001	F - 18	26	SA8679001	A - 13	2	SB2456001	A - 14	2	SB4372001	C3 - 20	10
SA6182001	B - 19	4	SA8684001	D1 - 40	18		T3 - 33	58	SB4373001	C4 - 48	12
SA6207001	A - 24	2	SA8689001	D1 - 43	18	SB3511001	E - 26	24	SB4374001	C4 - 21	12
SA6210001	D2 - 42	20	SA8691001	G - 17	28	SB3847001	J - 56	34	SB4375001	C4 - 20	12
	D3 - 20	22	SA8707001	E - 45	24		J - 63	34	SB4376001	C4 - 23	12
SA6261002	Z - 68	64	SA9004001	B - 49	4	SB3848001	C1 - 38	6	SB4377001	C4 - 27	12
SA6272001	A - 21	2	SA9058001	Sp	68		C1 - 51	6	SB4378001	K - 8	36
SA6273101	J - 61	34	SA9191001	E - 30	24		D2 - 30	20	SB4379001	K - 5	36
SA6308001	C1 - 54	6	SA9207001	G - 19	28		D3 - 12	22	SB4380001	L - 9	38
SA6358101	C1 - 42	6	SA9396001	E - 21	24		K - 10	36	SB4381001	D2 - 2	20
SA6362001	T3 - 20	58	SA9397001	E - 23	24		T3 - 40	58	SB4382001	D2 - 20	20
SA6373001	T3 - 8	58	SA9500201	M1 - 4	40	SB3849001	C4 - 36	12		D3 - 2	22
SA6391001	G - 3	28	SA9535001	M2 - 2+	42		C4 - 50	12	SB4383001	Z - 4	62
SA6397001	J - 53	34	SA9559001	M1 - 14	40		C5 - 42	14	SB4384001	A - 30	2
SA6398001	J - 53	34	SA9564001	M1 - 15	40		L - 14	38	SB4385001	A - 29	2
SA6405001	N - 14	44	SA9565001	M1 - 16	40	SB4037001	F - 57	26	SB4387001	F - 46	26
SA6405002	N - 16	44	SA9602101	M1 - 5	40	SB4096001	P - 14	46	SB4388001	F - 47	26
SA6406001	N - 15	44	SA9616001	M2 - 1+	42	SB4155001	F - 3	26	SB4389001	H - 1	30
SA6406002	N - 17	44	SA9725001	M1 - 13	40		J - 12	32	SB4392001	E - 27	24
SA6407001	N - 18	44		Wa	65		L - 11	38	SB4394001	J - 46	32
SA6448301	Sp	67	SA9793001	E - 24	24		P - 17	46	SB4395001	J - 40	32
SA6450101	C3 - 12	10		F - 54	26	SB4183001	C2 - 1	8	SB4396001	J - 45	32
	C3 - 24	10	SA9826001	A - 40	2	SB4184001	C1 - 9	6	SB4397001	J - 32	32
SA6451101	C3 - 13	10		Wa	65	SB4185301	C1 - 6	6	SB4398001	J - 38	32
	C3 - 25	10	SA9831001	M2 - 1+	42	SB4186201	C1 - 2	6	SB4399001	J - 35	32
SA6576001	F - 17	26	SA9893001	M1 - 9	40	SB4259001	P - 11	46	SB4400001	J - 44	32
	F - 59	26	SA9914001	M2 - 7	42	SB4260001	P - 5	46	SB4401001	J - 24	32
SA6580001	F - 15	26		Wa	65	SB4261001	P - 12	46	SB4402001	C1 - 10	6
SA6593001	F - 14	26	SA9957001	A - 42	2	SB4275001	C3 - 7	10	SB4403001	Z - 2	62
SA6594001	C2 - 11	8		C1 - 55	6	SB4276001	C3 - 19	10	SB4404001	C4 - 2	12
SA6595001	C6 - 13	16		Wa	65	SB4277001	D2 - 22	20		C5 - 2	14



CODE	REF.NO	Page	CODE	REF.NO	Page	CODE	REF.NO	Page	CODE	REF.NO	Page
SB4405001	E - 11	24									
SB4406001	C1 - 14	6									
	C1 - 25	6									
SB4407001	C2 - 6	8									
SB4408001	C2 - 7	8									
SB4409001	C2 - 8	8									
SB4412001	Z - 1	62									
SB4413001	A - 27	2									
SB4414001	C4 - 18	12									
SB4415001	J - 33	32									
SB4416001	J - 21	32									
SB4420001	C4 - 34	12									
SB4421001	C4 - 24	12									
SB4422001	C4 - 25	12									
SB4423001	D2 - 5	20									
SB4424001	D2 - 4	20									
SB4430001	C1 - 5	6									
SB4431001	C1 - 28	6									
SB4432001	C1 - 11	6									
SB4433001	C4 - 1	12									
SB4453001	C4 - 42	12									
SB4454001	C5 - 1	14									
SB4455001	C5 - 31	14									
SB4456001	C5 - 36	14									
SB4457001	C4 - 47	12									
SB4458001	C3 - 6	10									
SB4459001	C3 - 18	10									
SB4460001	C5 - 44	14									
SB4461001	C5 - 45	14									
SB4464101	E - 28	24									
SB4467001	L - 1	38									
SB4468001	F - 41	26									
SB4469001	C1 - 24	6									
SB4508101	E - 13	24									
SB4509001	E - 14	24									
SB4516001	Z - 57	62									
SB4517001	Z - 56	62									
SB4524001	F - 23	26									
SB4525001	C4 - 53	12									
	C5 - 47	14									
SB4540101	M1 - 1	40									
SB4541001	M1 - 2	40									
SB4546101	Q - 2	48									
SB4547001	Q - 3	48									
SB4549001	Q - 4	48									
SB4570001	F - 56	26									
SB4573001	S - 4	52									
SB4595001	J - 48	34									
SB4689201	C1 - 53	6									
SB4713001	C6 - 18	16									
XD1115051	S - 6	52									

brother®

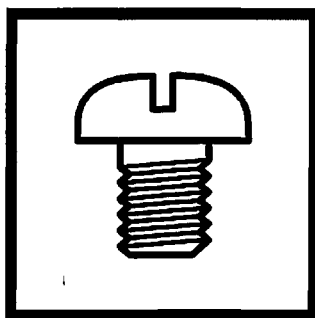

パーツブック  
PARTS BOOK

**ブラザー工業株式会社** <http://www.brother.co.jp/>  
〒448-0803 刈谷市野田町北地藏山1番地5 TEL:0120-33-2392  
**BROTHER INDUSTRIES, LTD.** <http://www.brother.com/>  
1-5, Kitajizoyama, Noda-cho, Kariya 448-0803, Japan. Phone : 81-566-95-0088

© 2013 Brother Industries, Ltd. All Rights Reserved.

BAS-311H  
SB4718-001.J/E  
2013.08.B (1)